



**Business Services
Contracts Office**

5735 47th Avenue • Sacramento, CA 95824
(916) 643-2464

*Rose Ramos, Chief Business Officer
Jessica Sulli, Contract Specialist*

ADDENDUM NO. 0

Date: May 11, 2022

Issued by: Sacramento City Unified School District

Project: **SCUSD Project No. 454-2
Shade Structures Group 1B**

This Addendum shall supersede the original Information, attachments, and specifications regarding RFQ/P where it adds to, deletes from, clarifies or otherwise modifies them. All other conditions and any previous addenda shall remain unchanged.

AD0.01 - Hazmat Reports

A. Reference Hazmat Reports, Sample Maps and SMAQMD forms attached

AD0.02 - Project Manual

A. Table of Contents

1. DELETE Table of Contents in its entirety and REPLACE with Table of Contents included with this addendum.

B. Division 00, Section 00 52 13

1. DELETE Section 00 52 13 and replace with revised Section 00 52 13 attached

C. Division 01, Section 01 32 13, Paragraph 1.03

1. DELETE Section 01 32 13, Paragraph 1.03 and replace with revised Section 01 32 13, Paragraph 1.03 attached

D. Section 07 9200, Joint Sealants

1. ADD Section 07 9200, Joint Sealants included with this addendum.

E. Section 09 9100, Painting



1. ADD Section 09 9100, Painting included with this addendum.

AD0.03 – For 02-119974 Shade Structure at John Sloat Elementary School

Drawings

- A. Sheet A0.2, Typical Mounting Heights and Details
 1. Detail 8, Hydration Station Guardrail: REVISE per sheet AD0.01 included with this addendum
- B. Sheet C0.1, Civil General Notes and Abbreviations
 1. ADD Landscape / Irrigation Note per sheet AD0.02 included with this addendum.
- C. Sheet A1.1.1, Partial Site Plans and Details
 1. Detail 2, Enlarged Site Plan – Shade Structure: REVISE site plan to now show a section callout at the shade structure column per sheet AD0.03 included with this addendum.
 2. Sheet Note 4: ADD note. Text to read “For footing / concrete pad / column interaction, see PC shade structure / deferred approval”
- D. Sheet E1.1, Site Plan - Electrical
 1. REVISE conduit and ground rod callouts per sheet AD0.04 included with this addendum.
 2. REVISE Keyed Notes 1 and 3 per sheet AD0.04 included with this addendum.
 3. ADD Keyed Note 8 per sheet AD0.04 included with this addendum.
- E. Sheet E3.1, Details
 1. Detail 2, Typical H/20 Traffic Rated Pull Box: REVISE per sheet AD0.05 included with this addendum.
 2. Detail 4, Conduit Stub in Post Detail: REVISE per sheet AD0.05 included with this addendum.
 3. Detail 5, Typical Steel Column & Rebar Grounding Detail: REVISE per sheet AD0.05 included with this addendum.
- F. Sheet 2, Statement of General Conformance
 1. ADD Statement of General Conformance sheet per sheet AD0.06 included with this addendum
- G. Sheet LS1.0, General Info
 1. DELETE in its entirety and REPLACE with sheet AD0.07 included with this addendum



- H. Sheet LS1.1, DSA 103
 - 1. DELETE in its entirety and REPLACE with sheet AD0.08 included with this addendum
- I. Sheet LS3.0, 30' Wide Rectangular Hip Foundation Plan
 - 1. DELETE in its entirety and REPLACE with sheet AD0.09 included with this addendum
- J. Sheet LS3.1, 30' Wide Rectangular Hip Framing & Connection Details
 - 1. DELETE in its entirety and REPLACE with sheet AD0.10 included with this addendum
- K. Sheet LS3.4, 30' Rectangular Hip Standing Seam Roofing Plan
 - 1. DELETE in its entirety and REPLACE with sheet AD0.11 included with this addendum
- L. Sheet LS5.0, Electrical Access
 - 1. DELETE in its entirety and REPLACE with sheet AD0.12 included with this addendum

AD0.04 – For 02-119977 Shade Structure at Leataata Elementary School

Drawings

- A. Sheet A0.2, Typical Mounting Heights and Details
 - 2. Detail 11, Hydration Station Guardrail: REVISE per sheet AD0.01 included with this addendum
- B. Sheet C0.1, Civil General Notes and Abbreviations
 - 2. ADD Landscape / Irrigation Note per sheet AD0.02 included with this addendum.
- C. Sheet A1.1.2, Partial Site Plans and Details
 - 3. Sheet Note 4: REVISE to read "Drop inlet per civil"
- D. Sheet 2, Statement of General Conformance
 - 1. ADD Statement of General Conformance sheet per sheet AD0.03 included with this addendum
- E. Sheet LS1.0, General Info
 - 1. DELETE in its entirety and REPLACE with sheet AD0.04 included with this addendum



- F. Sheet LS1.1, DSA 103
 - 1. DELETE in its entirety and REPLACE with sheet AD0.05 included with this addendum
- G. Sheet LS3.0, 30' Wide Rectangular Hip Foundation Plan
 - 1. DELETE in its entirety and REPLACE with sheet AD0.06 included with this addendum
- H. Sheet LS3.1, 30' Wide Rectangular Hip Framing & Connection Details
 - 1. DELETE in its entirety and REPLACE with sheet AD0.07 included with this addendum
- I. Sheet LS3.4, 30' Rectangular Hip Standing Seam Roofing Plan
 - 1. DELETE in its entirety and REPLACE with sheet AD0.08 included with this addendum
- J. Sheet LS5.0, Electrical Access
 - 1. DELETE in its entirety and REPLACE with sheet AD0.09 included with this addendum

AD0.05 – For 02-119978 Shade Structure Alice Birney Public Waldorf K-8 School

Drawings

- A. Sheet A0.7, Local Fire Authority Site Plan
 - 3. Detail 1, Local Fire Authority Site Plan: REVISE planter at Unit SS to curb per AD0.03
- B. Sheet C0.1, Civil General Notes and Abbreviations
 - 3. ADD Landscape / Irrigation Note per sheet AD0.01 included with this addendum.
- C. Sheet C1.1, Demolition, Grading and Paving Plan
 - 1. REVISE existing gas and irrigation line demolition and new scope and all applicable callouts to now include rerouting of these utilities per sheet AD0.02 included with this addendum.
 - 2. REVISE planter at Unit SS to curb per sheet AD0.02 included with this addendum.
 - 3. REVISE Grading Notes 16 and 18 per sheet AD0.02 included with this addendum.
 - 4. ADD Grading Note 19 per sheet AD0.02 included with this addendum.
 - 5. ADD Demolition Note 5 per sheet AD0.02 included with this addendum.
 - 6. Detail 2, Concrete Curb: REVISE per sheet AD0.02 included with this addendum.



7. Detail 4, Water Trench: ADD per sheet AD0.02 included with this addendum.
- D. Sheet A1.1.0, Site Plan and Code Information
1. Detail 1, Site Plan: REVISE planter at Unit SS to curb per AD0.03
- E. Sheet A1.1.1, Partial Site Plans and Details
1. Detail 2, Enlarged Site Plan – Shade Structure: REVISE per sheet AD0.03 included with this addendum
 2. Sheet Note 5: ADD note. Text to read “For footing / concrete pad / column interaction, see PC shade structure / deferred approval”
- F. Sheet E1.1, Site Plan - Electrical
1. REVISE conduit and ground rod callouts per sheet AD0.04 included with this addendum.
 2. REVISE Keyed Notes 1 and 3 per sheet AD0.04 included with this addendum.
 3. ADD Keyed Notes 6 and 7 per sheet AD0.04 included with this addendum.
- G. Sheet E3.1, Details
1. Detail 2, Typical H/20 Traffic Rated Pull Box: REVISE per sheet AD0.05 included with this addendum.
 2. Detail 3, Typical Trench Detail: REVISE per sheet AD0.05 included with this addendum.
 3. Detail 4, Conduit Stub in Post Detail: REVISE per sheet AD0.05 included with this addendum.
 4. Detail 5, Typical Steel Column & Rebar Grounding Detail: REVISE per sheet AD0.05 included with this addendum.
- H. Sheet 2, Statement of General Conformance
1. ADD Statement of General Conformance sheet per sheet AD0.06 included with this addendum
- I. Sheet LS1.0, General Info
1. DELETE in its entirety and REPLACE with sheet AD0.07 included with this addendum
- J. Sheet LS1.1, DSA 103
1. DELETE in its entirety and REPLACE with sheet AD0.08 included with this addendum
- K. Sheet LS3.0, 30’ Wide Rectangular Hip Foundation Plan
1. DELETE in its entirety and REPLACE with sheet AD0.09 included with this addendum
- L. Sheet LS3.1, 30’ Wide Rectangular Hip Framing & Connection Details



1. DELETE in its entirety and REPLACE with sheet AD0.10 included with this addendum
- M. Sheet LS3.4, 30' Rectangular Hip Standing Seam Roofing Plan
1. DELETE in its entirety and REPLACE with sheet AD0.11 included with this addendum
- N. Sheet LS5.0, Electrical Access
1. DELETE in its entirety and REPLACE with sheet AD0.12 included with this addendum

AD0.06 – 02-119979 Shade Structure at John Bidwell Elementary School

Drawings

- A. Sheet C0.1, Civil General Notes and Abbreviations
4. ADD Landscape / Irrigation Note per sheet AD0.01 included with this addendum.
- B. Sheet A1.1.1, Partial Site Plans and Details
4. Detail 2, Enlarged Site Plan – Shade Structure: REVISE site plan to now show a section callout at the shade structure column per sheet AD0.02 included with this addendum.
 5. Sheet Note 4: ADD note. Text to read “For footing / concrete pad / column interaction, see PC shade structure / deferred approval”
- C. Sheet E1.1, Site Plan - Electrical
1. REVISE conduit and ground rod callouts per sheet AD0.03 included with this addendum.
 2. REVISE Keyed Notes 1 and 3 per sheet AD0.03 included with this addendum.
 3. ADD Keyed Note 7 per sheet AD0.03 included with this addendum.
- D. Sheet E3.1, Details
1. Detail 2, Typical H/20 Traffic Rated Pull Box: REVISE per sheet AD0.04 included with this addendum.
 2. Detail 3, Typical Trench Detail: REVISE per sheet AD0.04 included with this addendum.
 3. Detail 4, Conduit Stub in Post Detail: REVISE per sheet AD0.04 included with this addendum.
 4. Detail 5, Typical Steel Column & Rebar Grounding Detail: REVISE per sheet AD0.04 included with this addendum.
- E. Sheet 2, Statement of General Conformance
1. ADD Statement of General Conformance sheet per sheet AD0.05 included with this addendum



- F. Sheet LS1.0, General Info
 - 1. DELETE in its entirety and REPLACE with sheet AD0.06 included with this addendum
- G. Sheet LS1.1, DSA 103
 - 1. DELETE in its entirety and REPLACE with sheet AD0.07 included with this addendum
- H. Sheet LS3.0, 30' Wide Rectangular Hip Foundation Plan
 - 1. DELETE in its entirety and REPLACE with sheet AD0.08 included with this addendum
- I. Sheet LS3.1, 30' Wide Rectangular Hip Framing & Connection Details
 - 1. DELETE in its entirety and REPLACE with sheet AD0.09 included with this addendum
- J. Sheet LS3.4, 30' Rectangular Hip Standing Seam Roofing Plan
 - 1. DELETE in its entirety and REPLACE with sheet AD0.10 included with this addendum
- K. Sheet LS5.0, Electrical Access
 - 1. DELETE in its entirety and REPLACE with sheet AD0.11 included with this addendum

END OF ADDENDUM NO. 0

Vendor to sign as acknowledgment of receipt and return with Bid:

Signature: _____ Date: _____

Company Name (please print) _____

**Asbestos and Lead Building
Inspection/Survey**

**Leataata Floyd Elementary School
Buildings A, C1, and D1**

**401 McClatchy Way
Sacramento, CA 95818**

Presented to:

*Mike Taxara
Facilities Project Technician*

*Sacramento City Unified School District
425 1st Avenue
Sacramento, CA 95818*

Inspection Date:

April 13, 2022

Reviewed and submitted by:

*Michael J. Lee
Certified Asbestos Consultant
Certified Lead Inspector/Assessor
Registered Environmental Property Assessor*

Conducted by:

*Joseph Wilkins
Certified Site Surveillance Technician
Certified Lead Sampling Technician*

National Analytical Laboratories, Inc.

2201 Francisco Dr., Ste. 140-261

El Dorado Hills, CA 95742

Office: (916) 361-0555 | Fax: (916) 361-0540

E-Mail: NAL1@NAL1.com | Web Page: www.NAL1.com





April 13, 2022

Mike Taxara
Facilities Project Technician
Sacramento City Unified School District
425 1st Street
Sacramento, CA 95818

**RE: Asbestos and Lead Building Inspection/Survey
Leataata Floyd Elementary School
Buildings A, C1, and D1
401 McClatchy Way
Sacramento, California 95818**

Dear Mr. Taxara,

The following report is regarding the building inspection conducted at the above site. **Of the nine (09) suspected asbestos-containing samples collected, none (0) were found to contain asbestos. Eighteen (18) XRF shots were obtained to make a total of the six (06) suspected lead-containing areas tested, one (01) was found to contain Lead-Based Material (LBM).** Joseph Wilkins, Certified Site Surveillance Technician and Lead Sampling Technician working with National Analytical Laboratories, Inc. (N.A.L.), conducted the inspection on April 14, 2022.

SUMMARY OF FINDINGS -

The building inspection and analytical results indicate that no asbestos is present in the areas that are being renovated.

Based on the lead sample results, the Building 1, Boy's Restroom, Ceramic Tiles on the Walls were found to contain LBM levels above Cal-OSHA's lead limit of detection.

SECTION I: ASBESTOS INSPECTION -

The inspection was completed according to the EPA's Asbestos Containing Building Materials (ACBM) In-Schools Rule; 40 CFR 763.85 (Inspection and Re-Inspection). Currently, the EPA regulations classify ACBM as materials containing more than 1-percent (1%) of asbestos. Cal-OSHA currently regulates asbestos to 1/10th of 1% (0.1%) and requires a certified asbestos worker to conduct this work.

Breathe easy...

2201 Francisco Dr. Ste. 140-261 El Dorado Hills, CA 95762
916.361.0555 | Email: Service@nal1.com

Upon completing the visual inspection, the suspect asbestos bulk sample materials were collected under the EPA and Cal-OSHA protocol. They were placed into new plastic bags, sealed, and identified with unique identification numbers. The bulk samples were transported to the laboratory under a chain of custody protocol for analysis. MircoTest Laboratory, located in Rancho Cordova, CA, analyzed the bulk suspect asbestos-containing samples, utilizing the Polarized Light Microscopy (PLM) Method. National Voluntary Laboratory Accreditation Program (NVLAP), certification #200999-0, California Environmental Laboratory Accreditation Program (CAELAP), certification #2974, certifies MicroTest.

Minor destructive renovation sampling was conducted during the site visit. If renovation/demolition work reveals any unforeseen suspect materials or if any future renovation work is to be conducted in other areas at the site, the Contractor shall cease all work and contact the building owner for further testing.

Not all the rooms or materials throughout the site were sampled. According to the results, the like materials that were not tested will be treated as homogeneous to the tested materials and will be considered asbestos or non-asbestos.

The following samples were **non-asbestos-containing materials**:

Sample ID#	Material	Location	Results
401-1A	Stucco	Bldg. A, Exterior, N. Wall, Damage	None Detected
401-1B	Stucco	Bldg. A, Exterior, E. Wall, Damage	None Detected
401-1C	Stucco	Bldg. A, Exterior, S. Wall, Damage	None Detected
401-2A	Plaster	Bldg. C1, N. Wall, Damage	None Detected
401-2B	Plaster	Bldg. C1, W. Wall, Outlet	None Detected
401-2C	Plaster	Bldg. C1, Light Switch	None Detected
401-3A	Plaster	Bldg. D1, S. Wall, Damage	None Detected
401-3B	Plaster	Bldg. D1, S. Wall, Damage	None Detected
401-3C	Plaster	Bldg. D1, N. Wall, Damage	None Detected

ASBESTOS CONCLUSION -

No asbestos was detected in the above-listed samples/materials. Therefore, the contractor, their employees, or the sub-contractors, can complete their work, in the specific areas tested, without any health or safety concerns regarding the exposure to airborne asbestos fibers.

SECTION II: LEAD INSPECTION –

The lead suspect samples were collected according to the Housing Urban Development (HUD) Guidelines, the Environmental Protection Agency (EPA), and the California Public Health Department (formally DHS), which regulate and require the abatement or in-place management of LBM/LBP hazards equal to or greater than 1.0 milligram per square centimeter (1.0 mg/cm²) of lead by XRF analysis or more than 0.5% lead by weight by laboratory flame atomic absorption. The following regulation shall be adhered to because Cal-OSHA considers all surfaces to contain Lead: Cal-OSHA's 29 CFR 1926.62, California Occupational Safety and Health Standard, Title 8 (Cal-OSHA 8 CCR 1532.1).

Upon completing the visual inspection, suspect painted finishes or materials were sampled for potential lead content, following the EPA and Cal-OSHA protocol. They were labeled with unique identification numbers and analyzed using the Heuresis Pb200i Portable X-ray Fluorescent (XRF) analyzer. When the materials are measured using XRF, each element



present in the sample emits its own unique fluorescent x-ray energy spectrum. We can rapidly determine the material's lead content by simultaneously measuring the fluorescent x-rays emitted by the sample's different components.

Once the determination is made on where the LBM is located, the In-place Management or the Abatement of the LBM can commence. If the Abatement method of all surfaces is to be completed, then the debris must be bagged, or burrito wrapped before removing the debris from the work area(s) and subsequently the site. Because the samples listed below were found to contain LBM all areas where the LBM will be disturbed will require abatement, encapsulation, or prep work by a certified lead worker.

Therefore, the employer must ensure that the worker is adequately trained under Title 8 (Cal-OSHA 8 CCR 1532 (1) (2) and shall produce evidence that the worker is not being exposed above the Action Level (AL) or the Permissible Exposure Limit (PEL). Suppose no current data is readily available for the worker(s). In that case, the employer shall conclude that the worker is being exposed above the PEL; this SHALL trigger the employer to provide advanced training and certifications for the employees working with LBM.

Although not all the rooms or materials (non-suspect) were sampled, the like materials that were not tested and their results will be treated as homogeneous. The materials will be treated as containing LBM throughout the site.

The location and results of the suspect sample **found to be LBM** is as follows:

Sample ID:	Sample Location Description	Structure	Color	Lead (mg/cm ²)
401-5L	Building D1, Boys Restrooms Walls	Ceramic Tiles	Yellow	4.0 LBM

Before the renovation/demolition work is completed or the transporting of the debris from the site, Health, and Safety Code 25157.8 (AB 2784 National Resources) requires that all lead debris be sampled for Waste Characterization. This will help the Contractor decide whether the material is to be considered Hazardous or Non-Hazardous Lead waste or general construction debris. The sequence of testing to be completed by the Contractor is as follows:

- Total Threshold Limit Concentration (TTLC) resulting from 50 mg/kg or more but less than 1,000 mg/kg of lead must be retested using the Soluble Threshold Limit concentration (STLC) method.
- An STLC result of 5.0 mg/L or greater is considered California Hazardous Waste.
- Total Characteristic Leaching Procedure (TCLP) testing shall only be accomplished when approved by the Owners Representative; This procedure shall be generally reserved for out-of-state shipments, and A TCLP result of 5.0 mg/L or more deems the waste Federal RCRA materials; and
- The California hazardous waste threshold for total lead using STLC is 5 mg/L.



The following were found to be less than (<) Cal-OSHA's Limit of Detection:

Sample ID:	Sample Location Description	Structure	Color	Lead (mg/cm ²)
401-1L	Bldg. A, Exterior Walls, Paint	Stucco	Multi	<LOD
401-2L	Bldg. A, Interior Walls, Paint	Wood	Multi	<LOD
401-3L	Bldg. C1, Interior Walls, Paint	Plaster	Beige	<LOD
401-4L	Bldg. D1, Interior Walls, Paint	Plaster	Beige	<LOD
401-6L	Bldg. D1, Girl's Restroom Walls, Tiles	Ceramic	Blue	<LOD

LEAD RECOMMENDATION -

To stabilize the current lead conditions, N.A.L recommends Lead Certified CDPH Workers conduct in-place management work of the LBM surfaces/sample scheduled for renovation/demolition. Once the abatement, in-place management, or prep work is completed and the areas are stabilized, the existing surfaces/samples will be in good condition and not create a health or safety concern to the workers conducting the general construction work at the site. A Scope of Work or specifications should be utilized to conduct the lead work at the site.

ASSUMPTIONS AND LIMITATIONS:

The results, findings, conclusions, and recommendations expressed in this report are based only on conditions noted during N.A.L.'s inspection of the specific areas listed herein.

The selection of sample locations and sampling frequency was based on observations and the assumption that like materials in the same area are homogeneous in content. This report is not to be utilized as a bidding document or a project specification document since it does not have all the components required to serve as an Asbestos & Lead Abatement Project Design document or an Asbestos & Lead Abatement Work plan.

Our professional services have been performed, our findings obtained, and our conclusions and recommendations prepared following established principles and practices in environmental testing and consulting. This report does not warrant undiscovered hazards and locations not investigated.



This report includes the laboratory analytical results, chain custody forms, and sample location map. If you have any questions regarding this report or can be of further assistance, please get in touch with our office.

Reviewed and submitted by:



Michael J. Lee
Certified Asbestos Consultant
DOSH# 06-4047
Certified Lead Inspector/Assessor
LRC-00007541
Registered Environmental Property Assessor
REPA# 716352750

Conducted by:



Joseph Wilkins
Certified Site Surveillance Technician
DOSH# 17-5890
Certified Lead Sampling Technician





MicroTest Laboratories Inc. NVLAP Code: 200999-0
 3110 Gold Canal Dr. Ste. A. Rancho Cordova, CA 95670
 PH 916.567.9808 | FX 916.404.0302
 www.microtestlabsinc.com | service@microtestlabsinc.com

Project ID
MT012218930

CLIENT INFORMATION

Company National Analytical Laboratories, Inc.
Name Paula Lee
Address 2201 Francisco Drive, Ste. 140-261
 El Dorado Hills CA, 95762
Phone (916) 361 - 0555
Email N.A.L. Distribution List

SAMPLE

Date Wednesday, April 13, 2022
Time 8:00 AM

JOB SITE INFORMATION

Sampler Joseph Wilkins
Project Address Leataata Floyd Elementary Property
 401 McClatchy Way
 Sacramento, CA 95818

MicroTest
Laboratories
 Analytical Data

POLARIZED LIGHT MICROSCOPY (PLM)

EPA METHOD 600 / R-93 / 116 & EPA – 40 CFR Appendix E to Subpart E of Part 763

Sample ID	Accession Number	Client Description	Laboratory Description	Non Fibrous / Fibrous Materials	Asbestiform Minerals %
401-1A	18930-1	Bldg. A, Exterior, N. Wall, Damage	Multi Colored Stucco Non-Fibrous Homogenous	100% Binder	None Detected
401-1B	18930-2	Bldg. A, Exterior, E. Wall, Damage	Multi Colored Stucco Non-Fibrous Homogenous	100% Binder	None Detected
401-1C	18930-3	Bldg. A, Exterior, S. Wall, Damage	Multi Colored Stucco Non-Fibrous Homogenous	100% Binder	None Detected
401-2A	18930-4	Bldg. C1, N. Wall, Damage	Multi Colored Plaster Non-Fibrous Homogenous	100% Binder	None Detected
401-2B	18930-5	Bldg. C1, W. Wall, Outlet	Multi Colored Plaster Non-Fibrous Homogenous	100% Binder	None Detected
401-2C	18930-6	Bldg. C1, Light Switch	Multi Colored Plaster Non-Fibrous Homogenous	100% Binder	None Detected

Report

Date Wednesday, April 13, 2022

Samples Received: 9
Samples Analyzed: 9

Analyst: Kelly Favero

Authorized Signatory:

Kelly Favero - Lab Manager

This analytical data sheet constitutes a final report. Due to the limitation of Polarized Light Microscopy (PLM), some samples classified as containing no asbestos in materials, NoneDetected (ND), such as floor tiles or like materials, warrant a recommendation for further analysis by Transmission Electron Microscopy (TEM). Results apply to the sample as received. This report must not be used by the client to claim product endorsement by NVLAP or any agency of the U.S. Government. All Samples will be held for not less than 30 days, upon which they will then be disposed of. This report shall not be reproduced in full without written authorization from MicroTest Laboratories, Inc. Soil and rock matrices are considered problematic matrices and MicroTest recommends sample homogenization prior to PLM analysis. Thermal decomposition of asbestos fibers can yield non-asbestiform mineral properties. The reporting limit for calibrated visual area estimation quantitation procedures is 1%. The reporting limit for 400/1000 point count quantitation procedures is 0.25% or 0.1% respectively. The sample is considered acceptable unless otherwise noted. Sub-samples are analyzed separately accept when manufactured with multiple layers (i.e. Linoluem, Drywall, etc.) or requested contrarily by the client



MicroTest Laboratories Inc. NVLAP Code: 200999-0
 3110 Gold Canal Dr. Ste. A. Rancho Cordova, CA 95670
 PH 916.567.9808 | FX 916.404.0302
 www.microtestlabsinc.com | service@microtestlabsinc.com

Project ID
MT012218930

401-3A	18930-7	Bldg. D1, S. Wall, Damage	Multi Colored Plaster Non-Fibrous Homogenous	100% Binder	None Detected
401-3B	18930-8	Bldg. D1, S. Wall, Damage	Multi Colored Plaster Non-Fibrous Homogenous	100% Binder	None Detected
401-3C	18930-9	Bldg. D1, N. Wall, Damage	Multi Colored Plaster Non-Fibrous Homogenous	100% Binder	None Detected

Report	
Date	Wednesday, April 13, 2022

Samples Received: 9
Samples Analyzed: 9

Analyst: Kelly Favero

Authorized Signatory:

Kelly Favero - Lab Manager

This analytical data sheet constitutes a final report. Due to the limitation of Polarized Light Microscopy (PLM), some samples classified as containing no asbestos in materials, NoneDetected (ND), such as floor tiles or like materials, warrant a recommendation for further analysis by Transmission Electron Microscopy (TEM). Results apply to the sample as received. This report must not be used by the client to claim product endorsement by NVLAP or any agency of the U.S. Government. All Samples will be held for not less than 30 days, upon which they will then be disposed of. This report shall not be reproduced in full without written authorization from MicroTest Laboratories, Inc. Soil and rock matrices are considered problematic matrices and MicroTest recommends sample homogenization prior to PLM analysis. Thermal decomposition of asbestos fibers can yield non-asbestiform mineral properties. The reporting limit for calibrated visual area estimation quantitation procedures is 1%. The reporting limit for 400/1000 point count quantitation procedures is 0.25% or 0.1% respectively. The sample is considered acceptable unless otherwise noted. Sub-samples are analyzed separately accept when manufactured with multiple layers (i.e. Linoluem, Drywall, etc.) or requested contrarily by the client



Project ID
MT012218930

CLIENT INFORMATION

Company Sac City Unified School District
Name Mike Taxara
Address 425 First Avenue
Sacramento CA, 95818
Phone (916) 395 - 3980
Email Tina-Alvarez-Bevens@scusd.edu

Sample

Date Wednesday, April 13, 2022
Time 08:00 AM

Chain-Of-Custody

JOB SITE INFORMATION

Site Leataata Floyd Elementary Property
Address 401 McClatchy Way
Sacramento, CA 95818
Unit
Claim#
Job # 40814
Chain # 1

Analysis: PLM | TTFP - 400 PT.CT.

Turn Around Time: Same Day

Sample Number:	Location	Description
401-1A	Bldg. A, Exterior, N. Wall, Damage	Stucco
401-1B	Bldg. A, Exterior, E. Wall, Damage	Stucco
401-1C	Bldg. A, Exterior, S. Wall, Damage	Stucco
401-2A	Bldg. C1, N. Wall, Damage	Plaster
401-2B	Bldg. C1, W. Wall, Outlet	Plaster
401-2C	Bldg. C1, Light Switch	Plaster
401-3A	Bldg. D1, S. Wall, Damage	Plaster
401-3B	Bldg. D1, S. Wall, Damage	Plaster
401-3C	Bldg. D1, N. Wall, Damage	Plaster

Relinquished by (Client)	Date/Time

Received by (Tech)	Date/Time

Relinquished by (Tech)	Date/Time
<i>Am Wilkins</i>	04/13/2022 08:00 AM

Received by (Lab)	Date/Time
<i>Adriana</i>	04/13/2022 1:51 PM

Sampler: Joseph Wilkins

Total Number of Samples 9



PH 916.361.0555 | FX 916.361.0540
service@nall.com

KS#
Client PO
Project ID

for office use only

CLIENT INFORMATION

Company Sac City Unified School District
Name Mike Taxara
Address 425 First Avenue
Sacramento CA, 95818
Phone (916) 395 - 3980
Email Tina-Alvarez-Bevens@scusd.edu

SAMPLE

Date Wednesday, April 13, 2022
Time 08:00 AM
Chain-Of-Custody | Analytical Data
Heuresis Pb200i

JOB SITE INFORMATION

Site Leataata Floyd Elementary Property
Address 401 McClatchy Way
Sacramento, CA 95818
Unit
Claim#
Job # 26208
Chain # 1

TURN AROUND Same Day	LEAD PAINT Inspection	MEASUREMENT MODE Standard	SAMPLING METHOD Heuresis Pb200i	ANALYTICAL DATA Action Level - 1 Abatement Level - 1 Total Readings - 6
--------------------------------	---------------------------------	-------------------------------------	---	---

Sample ID:	Sample Location Description	Structure Material	Color	Condition	Lead (mg/cm ²)
401-1L	Bldg. A, Exterior Walls, Paint	Stucco	Multi	N/A	<LOD
401-2L	Bldg. A, Interior Walls, Paint	Wood	Multi	N/A	<LOD
401-3L	Bldg. C1, Interior Walls, Paint	Plaster	Beige	N/A	<LOD
401-4L	Bldg. D1, Interior Walls, Paint	Plaster	Beige	N/A	<LOD
401-5L	Bldg. D1, Boy's Restroom Walls, Tiles	Ceramic	Yellow	Intact	4.0
401-6L	Bldg. D1, Girl's Restroom Walls, Tiles	Ceramic	Blue	N/A	<LOD

<LOD Below Limit of Detection | Reading < 0.0

LCM Lead Containing Material | Readings Ranging from 0 to < 1.0 mg/cm²

LBP Lead Based Paint | Readings Greater than 1.0 mg/cm²

ANALYSIS

Date	April 13, 2022
Time	08:00 AM

California Dept. of Public Health
www.2.epa.gov/lead



Relinquished by (Client)	Date/Time

Relinquished by (Tech)	Date/Time
<i>Joseph Wilkins</i>	04/13/2022 08:00 AM

Sampler: Joseph Wilkins

Analyst: Joseph Wilkins

Received by (Tech)	Date/Time

Received by (Lab)	Date/Time
<i>Joseph Wilkins</i>	04/13/2022 08:00 AM

Total Number of Samples 6

ASBESTOS SAMPLE LOCATION MAP Survey Date: 04/13/22 Area: Buildings A, C1 & D1	Site Name: Leataata Floyd E.S. Site Address: 401 McClatchy Way Sacramento, CA	Project#: Scale: Not to Scale Layout and Sample Locations Are Approximated. Legend: - Non-Asbestos + Contains Asbestos
--	--	--

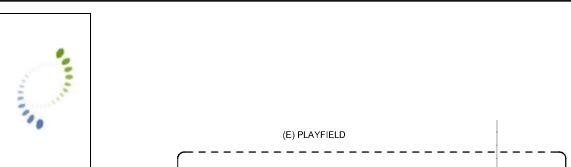

PROPOSED SHADE STRUCTURE				
UNIT	DESCRIPTION	CONSTRUCTION TYPE	OCCUPANCY	ALLOWABLE AREA
SS	SHADE STRUCTURE	IB OR	A3	9,500 SF MAX
		V-B	A-5	6,000 SF MAX

EXISTING BUILDING DESIGNATIONS				
UNIT	DESCRIPTION	DSA APPLICATION #	AREA (SF)	NOTES
A	MULTIPURPOSE	9853	5,069	
B	ADMINISTRATION	9853	6,092	
C1&2	CLASSROOMS / TOILET ROOMS	9853, THIS APPLICATION	6,425	
D1&2	CLASSROOMS / TOILET ROOMS	9853, THIS APPLICATION	6,425	
E1&2	CLASSROOMS / TOILET ROOMS	9853	6,425	
F1&2	CLASSROOMS / TOILET ROOMS	9853	6,425	
G	RELOCATABLE CLASSROOMS	-	960	
H	RELOCATABLE CLASSROOMS	-	960	

EXISTING PATH OF TRAVEL (PC) ARCHITECT STATEMENT

THE PROFESSIONAL ARCHITECT'S RESPONSIBILITY STATEMENT FOR THE PROJECT IS LIMITED TO THE DESIGN AND CONSTRUCTION OF THE PROJECT AS SHOWN ON THESE DRAWINGS. THE ARCHITECT'S RESPONSIBILITY DOES NOT EXTEND TO THE DESIGN OR CONSTRUCTION OF ANY OTHER WORK NOT SHOWN ON THESE DRAWINGS. THE ARCHITECT'S RESPONSIBILITY DOES NOT EXTEND TO THE DESIGN OR CONSTRUCTION OF ANY OTHER WORK NOT SHOWN ON THESE DRAWINGS. THE ARCHITECT'S RESPONSIBILITY DOES NOT EXTEND TO THE DESIGN OR CONSTRUCTION OF ANY OTHER WORK NOT SHOWN ON THESE DRAWINGS.

ACCESSIBLE PARKING STALL CALCULATION

TOTAL PARKING STALLS: 100
 REQUIRED ACCESSIBLE STALLS: 3 (2% TOTAL STALLS)
 AVAILABLE ACCESSIBLE STALLS: 1 (4% ACCESSIBLE STALLS)
 ALL ACCESSIBLE STALLS PROVIDED

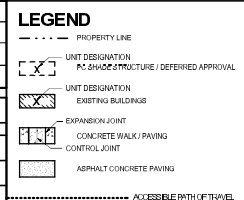

- SITE WALKWAYS SHALL PROVIDE A BARRIER-FREE PATH. BARRIER-FREE PATHS SHALL BE PROVIDED FOR ALL ACCESSIBLE ROUTES. BARRIER-FREE PATHS SHALL BE PROVIDED FOR ALL ACCESSIBLE ROUTES. BARRIER-FREE PATHS SHALL BE PROVIDED FOR ALL ACCESSIBLE ROUTES.
- WALKWAYS SHALL BE FREE OF OBSTACLES. WALKWAYS SHALL BE FREE OF OBSTACLES. WALKWAYS SHALL BE FREE OF OBSTACLES. WALKWAYS SHALL BE FREE OF OBSTACLES.
- WALKWAYS SHALL BE FREE OF OBSTACLES. WALKWAYS SHALL BE FREE OF OBSTACLES. WALKWAYS SHALL BE FREE OF OBSTACLES. WALKWAYS SHALL BE FREE OF OBSTACLES.
- WALKWAYS SHALL BE FREE OF OBSTACLES. WALKWAYS SHALL BE FREE OF OBSTACLES. WALKWAYS SHALL BE FREE OF OBSTACLES. WALKWAYS SHALL BE FREE OF OBSTACLES.
- WALKWAYS SHALL BE FREE OF OBSTACLES. WALKWAYS SHALL BE FREE OF OBSTACLES. WALKWAYS SHALL BE FREE OF OBSTACLES. WALKWAYS SHALL BE FREE OF OBSTACLES.
- WALKWAYS SHALL BE FREE OF OBSTACLES. WALKWAYS SHALL BE FREE OF OBSTACLES. WALKWAYS SHALL BE FREE OF OBSTACLES. WALKWAYS SHALL BE FREE OF OBSTACLES.
- WALKWAYS SHALL BE FREE OF OBSTACLES. WALKWAYS SHALL BE FREE OF OBSTACLES. WALKWAYS SHALL BE FREE OF OBSTACLES. WALKWAYS SHALL BE FREE OF OBSTACLES.

- SHEET NOTES**
- SN01 (4) HANDICAP LOT (2) TRASH RECEPTACLES (2) DECK (2) HOOP
 - SN02 ACCESSIBLE PARKING STALLS PER THE APPLICATION
 - SN03 (4) ACCESSIBLE TOILET ROOM UPGRADE PER THE APPLICATION
 - SN04 (4) ACCESSIBLE TOILET ROOM UPGRADE PER THE APPLICATION
 - SN05 (4) ACCESSIBLE TOILET ROOM UPGRADE PER THE APPLICATION
 - SN06 (4) ACCESSIBLE TOILET ROOM UPGRADE PER THE APPLICATION

SHADE STRUCTURE AT LEATAATA FLOYD ELEMENTARY SCHOOL

SACRAMENTO CITY UNIFIED SCHOOL DISTRICT
SACRAMENTO, CA

Revision

Copyright © 2022 (Project) Geo. Architects, All rights reserved. Reproduction of these drawings, whether in whole or in part, without the express written permission of Geo. Architects, is strictly prohibited.

SITE PLAN AND CODE INFORMATION

PROJECT NO: 2415645
DATE: 3/12/22
SHEET: A1.1.0

1 SITE PLAN
PC-3347

Asbestos Survey Form

(See Instructions)

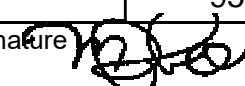
1. Purpose of Survey			Renovation			Demolition	
2. Facility Information							
Project Area(s) Description							
Leataata Floyd Elementary School			Buildings A, C1, & D1				
Address 401 McClatchy Way				City Sacramento		# of Structures	
3. Owner Information							
Name							
Address			City/State			Zip	
Contact		Phone		Fax		Email	
4. Consultant Information			Survey Date(s): 04/13/22				
Company Name							
National Analytical Laboratories, Inc.							
Name Michael J. Lee						DOSH # 06-4047	
Address 2201 Francisco Dr. Ste. 140-261			City/State El Dorado Hills, CA			Zip 95762	
Phone 916-361-0555		Fax 916-361-0540		Email Paula@nal1.com		Signature 	
5. Client Information (if different than owner)				<input type="checkbox"/> General Contractor		<input type="checkbox"/> Insurance Company	
<input type="checkbox"/> Architect				<input type="checkbox"/> Property Manager		<input type="checkbox"/> Other	
Name							
Address				City/State		Zip	
Contact		Phone		Fax		Email	
6. Have all of the suspect materials that will be disturbed been sampled?						<input checked="" type="checkbox"/> Yes <input type="checkbox"/> No	
If no, explain why:							
7. Summary of Total Asbestos Containing Material (ACM) Findings							
Regulated Asbestos Containing Material (RACM) <small>(Includes materials subject to known mechanical removal and fire damaged materials)</small>				Category II		Category I	
Square Ft.		Linear Ft.		Cubic Ft.		Square Ft.	
Linear Ft.		Square Ft.		Linear Ft.		Linear Ft.	
0		0		0		0	
0		0		0		0	
To receive future SMAQMD Rule updates and changes affecting your industry (check one box):							
<input type="checkbox"/> Please send e-mail notices to				<input type="checkbox"/> I will sign up myself at www.airquality.org/listserve/ to receive e-mailed notices.			
<input type="checkbox"/> I am already subscribed.		<input type="checkbox"/> I want the District to mail notices to the address on this application:				<input type="checkbox"/> Owner <input type="checkbox"/> Consultant	

SMAQMD Survey Form Instructions

- #1. Check the appropriate box as to whether the survey is for a Renovation or Demolition as defined by SMAQMD Rule 902, at the time the survey was conducted. Demolitions require sampling of all suspect materials unless assumed to contain asbestos or only a small area is being impacted by the demolition, ie, the entire building will not be razed. An example of this would be where only a load bearing wall(s) is removed but the building will remain intact. In those cases, explain why all suspect materials in the structure were not sampled in item #6. Renovations (TI's, soft demo's, remodels) require sampling of only the suspect materials that are going to be disturbed.
- #2. Provide the description and function of the building(s) or area(s), ie, "School-Boiler Room", within the building(s) being surveyed. Include the total number of floors surveyed. Provide the address of building(s) surveyed. If multiple buildings are on site, provide the total number of structures surveyed, include portables, outbuildings, garages, sheds, etc.
- #3. Provide owner information.
- #4. Provide consultant information and the date on which each building/area was surveyed in item #2.
- #5. The client refers to whoever requested the survey to be conducted and provided demolition/renovation information to the consultant. If the client is the owner in #3, leave this section blank.
- #6. Unless assumed to contain asbestos, **all** suspect materials must be sampled prior to a demolition. Prior to a renovation, unless assumed to contain asbestos, suspect materials >160 square feet, 260 linear feet, or 35 cubic feet that will be abated, stripped, or removed must be sampled. You cannot assume suspect materials are negative. Samples taken must be based on the Asbestos Hazard Emergency Response Act (AHERA) guidelines for homogeneous areas but must include both the interior and exterior suspect materials, floor to roof. The list below provides common suspect materials. Surfacing materials requiring 3,5,7 protocol are noted (3,5,7). The SMAQMD considers stucco a surfacing material. All other sampling may be done "sufficient to determine".

EPA Category of Common Suspect Asbestos Containing Materials

Note: This list does not include every product that may contain asbestos. It is intended as a general guide to show the proper NESHAP categories of materials typically containing asbestos.

Regulated Asbestos Containing Material

- Fireproofing (3,5,7)
- Acoustical Ceiling Texture (3,5,7)
- Plaster (3,5,7)
- Wall Texture (3,5,7)
- Ceiling Tiles
- HVAC Duct Insulation
- Thermal System Insulation
- Mudded Pipe Elbow Insulation
- Linoleum Backing
- Furnace Insulation
- Fire Doors
- Nicolite Roofing paper

Category II

- Stucco (3,5,7)
- Window Glazing
- Cement Board/Transite
- Mastics
- Textured Paints/Coatings
- Chalkboards
- Lab Hoods/Table Tops
- Cement Pipes
- Cement Roofing Shingles
- Caulking

Category I

- Asphalt Flooring
 - Roofing Shingles
 - Built-up Roofing
 - Base Flashing
 - Rolled Roofing
 - Boiler/Tank Insulation
 - Vinyl Floor Tile

#7. This is an estimate total of all RACM, Category I & Category II materials found in all structures listed in item #2. If Category I & II materials were subjected to fire or will be subjected to mechanical forces during removal, they must be designated as RACM. An asbestos containing material must only be designated to one category. Category I or II material cannot be listed as RACM.

Attachments (Include with Survey)

I. Findings & Recommendations

Explain the significance of the data in item #7. State that Category I material may be left in place during demolition and that RACM and Cementitious Category II material must be removed prior to the renovation or demolition. Explain that the amounts listed are to be used by the owner to obtain accurate bids from abatement contractors. State whether this is a jurisdictional project under the requirements of the federal NESHAP and SMAQMD Rule 902. For unimpacted areas in a renovation, state that untested suspect materials must be tested prior to additional future projects where the materials will be disturbed.

II. Floor Plan Map(s)

Create a separate Floor Plan Map (see example below) for each floor or area of every structure surveyed in item #2. If the roof or exterior is impacted by the project, create a separate map for the roof and exterior or include them on one of the floor maps as seen below. Name each room sampled by the commonly used name and state whether the area is undergoing Renovation or Demolition. A demolition is the wrecking, taking out or burning of any load supporting structural member. A renovation is everything else. If the survey is conducted after the demo/reno has occurred, inspect all dumpsters outside of building. Record the location of each sample taken and identify each sample with a unique identifier that will be the same as reported to the laboratory and in the following appendices. **Use “+” to describe >1% or “-” to describe = to or <1% asbestos.**

Example: Building 1 - Floor Plan Map

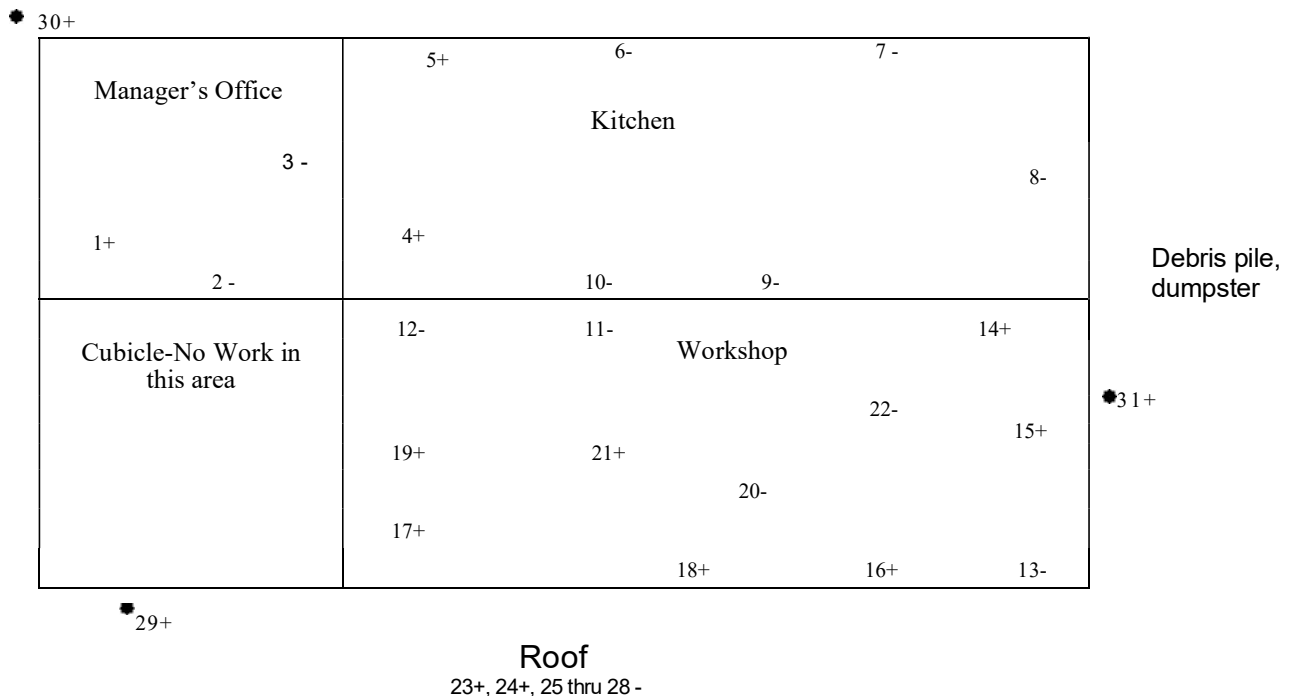

III. Sample Results

Create a table (see example below of minimal information needed to comply with SMAQMD Rule 902) for all samples >1% from all structures surveyed in item #2. Category I or Category II materials subject to known mechanical removal or fire damage must be considered RACM. Add more rows and columns as needed.

Example: Building 1 - Sample Results

Sample(s) ID#	Suspect Material	Asbestos Content (%) (PLM/PC)	EPA Category	Total Quantity Sq./Ln/Cu. Ft.
1	Ceiling tile	2.6-PC	RACM	250 sqft
4	Linoleum	40-PLM	RACM	800 sqft
5	Floor mastic	1.4-PC	RACM (mechanical removal)	250 sqft
14,16, 18	TSI	80-PLM	RACM	1,200 li.ft.
15,17, 19	Wall texture	3-PC	RACM	2,500 sqft
21	Floor tile	8-PLM	CAT II	2,500 sqft
20	Transite panels	45-PLM	CAT II	1,100 sqft
23	Nicolite felt	Assumed	RACM	12,000 sqft
24	Roof mastic	2-PLM	CAT I	12,000 sqft
29, 30, 31	Stucco	1.7 PC	RACM	5,400 sqft

IV. Lab Results

Point count (PC) all samples <10% unless assumed > 1%

V. Current proof of certification of person listed in item #4

Special Note: The following are common causes for survey rejection and potential citation by SMAQMD:

- (1)-Survey form or Appendices incomplete, incorrect or missing attachments.
- (2)-All suspect materials are not sampled or assumed to be asbestos containing in the survey (for any reason).
- (3)-Affected suspect materials are not sampled utilizing the 3,5,7 protocol.
- (4)-Point counts were not conducted, sheetrock was not composite sampled, non-sheetrock materials were composite sampled.

(5)-“**Limited Surveys** or Inaccessible Areas”- The SMAQMD is aware that renovations impact specific areas within a structure and therefore will not require sampling throughout the entire structure as a demolition survey would require. Stating that a **survey is “limited”** because all areas of the project will not be impacted or areas are inaccessible will result in rejection of the survey unless good cause is provided. There is no requirement to sample inaccessible materials, ie, materials behind a wall or encased in concrete; however, state in the “**Findings & Recommendations**” that upon discovery of previously untested, inaccessible suspect materials, work must cease until further sampling is conducted. Locked rooms or spaces above drop ceiling tiles are not considered inaccessible and are required to be sampled. The owner/operator must provide access to all impacted areas. Failure to sample suspect materials for “**cosmetic**” reasons will be rejected.

It is important to state that you cannot be prevented and/or instructed by the owner/operator as to what materials are to be sampled. This is determined by whoever conducts the survey and will give cause for survey rejection and potential citation to the owner/operator for failure to adequately survey all suspect materials.

Survey Instructions (4_13)

**Asbestos and Lead Building
Inspection/Survey**

**Alice Birney K-8
John Bidwell Elementary School
John Sloat Elementary School
New Joseph Bonnheim Elementary School
Tahoe Elementary School
Restrooms**

Presented to:

*Mike Taxara
Facilities Project Technician*

*Sacramento City Unified School District
425 1st Avenue
Sacramento, CA 95818*

Inspection Date:

May 06, 2022

Reviewed and submitted by:

*Michael J. Lee
Certified Asbestos Consultant
Certified Lead Inspector/Assessor
Registered Environmental Property Assessor*

Conducted by:

*Robert Mullen
Certified Site Surveillance Technician
Certified Lead Sampling Technician*

National Analytical Laboratories, Inc.
2201 Francisco Dr., Ste.140-261
El Dorado Hills, CA 95742
Office: (916) 361-0555 | Fax: (916) 361-0540
E-Mail: NAL1@NAL1.com | Web Page: www.NAL1.com



May 10, 2022

Mike Taxara
Facilities Project Technician
Sacramento City Unified School District
425 1st Avenue
Sacramento, CA 95818

RE: **Asbestos and Lead Building Inspection/Survey
Group 1 – 5 School Restrooms
Alice Birney K-8
John Bidwell Elementary School
John Sloat Elementary School
New Joseph Bonnheim Elementary School
Tahoe Elementary School
Sacramento, California**

Dear Mr. Taxara,

The following report is regarding the building inspection conducted at the various sites listed above. **Of the twenty-two (22) suspect asbestos-containing samples collected, none (0) were found to contain asbestos. Eighty-four (84) XRF shots were obtained to make a total of the twenty-eight (28) suspected lead-containing areas tested, four (04) were found to contain lead-based material (LBM).** Robert Mullen, Certified Site Surveillance Technician, and Lead Sampling Technician working with National Analytical Laboratories, Inc. (N.A.L.), conducted the inspection on May 06, 2022.

SUMMARY OF FINDINGS -

The building inspection and analytical results indicate that no asbestos is present in the areas that are being renovated.

Based on the lead sample results, the Girl's and Boy's Restroom Tiles were found to contain LBM levels at John Sloat and Tahoe Elementary school above Cal-OSHA's Lead Action Levels.

SECTION I: ASBESTOS INSPECTION -

The inspection was completed according to the EPA's Asbestos Containing Building Materials (ACBM) In-Schools Rule; 40 CFR 763.85 (Inspection and Re-Inspection). Currently, the EPA regulations classify ACBM as materials containing more than 1-percent (1%) of asbestos. Cal-OSHA currently regulates asbestos to 1/10th of 1% (0.1%) and requires a certified asbestos worker to conduct this work.

Breathe easy...

2201 Francisco Dr. Ste. 140-261 El Dorado Hills, CA 95762
916.361.0555 | Email: Service@nal1.com

Upon completing the visual inspection, the suspect asbestos bulk sample materials were collected under the EPA and Cal-OSHA protocol. They were placed into new plastic bags, sealed, and identified with unique identification numbers. The bulk samples were transported to the laboratory under a chain of custody protocol for analysis. MircoTest Laboratory, located in Rancho Cordova, CA, analyzed the bulk suspect asbestos-containing samples, utilizing the Polarized Light Microscopy (PLM) Method. National Voluntary Laboratory Accreditation Program (NVLAP), certification #200999-0, California Environmental Laboratory Accreditation Program (CAELAP), certification #2974, certifies MicroTest.

Minor destructive sampling was conducted during the site visit. In the event that demolition work reveals any unforeseen suspect materials or if any future renovation work is to be conducted in other areas at the site; the contractor shall cease all work and contact the building owner for further testing.

Not all the rooms or materials throughout the site were sampled. According to the results, the like materials that were not tested will be treated as homogeneous to the tested materials and will be considered asbestos or non-asbestos.

The following samples were non-asbestos-containing materials:

Alice Birney K-8

Sample ID#	Material	Location	Results
6251-1	Acoustic Ceiling Tile	Girl's Restroom Ceiling	None Detected
6251-2A	Linoleum	Girl's Restroom, Damage, Multicolor	None Detected
6251-2B	Mastic	Girl's Restroom, Damage	None Detected
6251-3A	Texture	Girl's Restroom, Damage	None Detected
6251-3B	Texture	Boy's Restroom, Light Switch	None Detected
6251-3C	Texture	Staff Restroom, Light Switch	None Detected
6251-4	Sheetrock-Joint Compound	Girl's Restroom, Damage	None Detected

John Bidwell ES

Sample ID#	Material	Location	Results
1730-1	Texture	Girl's Restroom, Damage	None Detected
1730-1	Texture	Boy's Restroom, Damage	None Detected
1730-1	Texture	Staff Restroom, Damage	None Detected
1730-2	Sheetrock-Joint Compound	Girl's Restroom, Damage	None Detected

John Sloat ES

Sample ID#	Material	Location	Results
7525-1A	Plaster	Girl's Restroom, Damage	None Detected
7525-1B	Plaster	Boy's Restroom, Damage	None Detected
7525-1C	Plaster	Staff Restroom, Damage	None Detected

Joseph Bonnheim ES

Sample ID#	Material	Location	Results
7300-1	Acoustic Ceiling Tile	Boy's Restroom Ceiling	None Detected



Tahoe ES

Sample ID#	Material	Location	Results
3110-1A	Texture	Staff Restroom, Damage	None Detected
3110-1B	Texture	Boy's Restroom, Damage	None Detected
3110-1C	Texture	Girl's Restroom, Damage	None Detected
3110-2	Sheetrock-Joint Compound	Staff Restroom, Damage	None Detected
3110-3A	Floor Tile	Staff Restroom, Damage, Multicolor	None Detected
3110-3B	Mastic	Staff Restroom, Damage	None Detected
3110-4	Cove Base Mastic	Staff Restroom, Damage	None Detected

ASBESTOS CONCLUSION -

No asbestos was detected in the above-listed samples/materials. Therefore, the contractor, their employees, or the sub-contractors, can complete their work, in the specific areas tested, without any health or safety concerns regarding the exposure to airborne asbestos fibers.

SECTION II: LEAD INSPECTION –

The lead suspect samples were collected according to the Housing Urban Development (HUD) Guidelines, the Environmental Protection Agency (EPA), and the California Public Health Department (formally DHS), which regulate and require the abatement or in-place management of LBP hazards equal to or greater than 1.0 milligram per square centimeter (1.0 mg/cm²) of lead by XRF analysis or more than 0.5% lead by weight by laboratory flame atomic absorption. The following regulation shall be adhered to because Cal-OSHA considers all surfaces to contain Lead: Cal-OSHA's 29 CFR 1926.62, California Occupational Safety and Health Standard, Title 8 (Cal-OSHA 8 CCR 1532.1).

Upon completing the visual inspection, suspect painted finishes or materials were sampled for potential lead content, following the EPA and Cal-OSHA protocol. They were labeled with unique identification numbers and analyzed using the Heuresis Pb200i Portable X-ray Fluorescent (XRF) analyzer. When the material is measured using XRF, each element present in the sample emits its own unique fluorescent x-ray energy spectrum. We can rapidly determine the material's lead content by simultaneously measuring the fluorescent x-rays emitted by the sample's different components.

Once the determination is made on where the LBM is located, the In-place Management or the Abatement of the LBM can commence. If the Abatement method of all surfaces is to be completed, then the debris must be bagged, or burrito wrapped before removing the debris from the work area(s) and subsequently the site. Because the samples listed below were found to contain LBM all areas where the LBM will be disturbed will require abatement, encapsulation, or prep work by a certified lead worker.

Therefore, the employer must ensure that the worker is adequately trained under Title 8 (Cal-OSHA 8 CCR 1532 (1) (2) and shall produce evidence that the worker is not being exposed above the Action Level (AL) or the Permissible Exposure Limit (PEL). Suppose no current data is readily available for the worker(s). In that case, the employer shall conclude that the worker is being exposed above the PEL; this SHALL trigger the employer to provide advanced training and certifications for the employees working with LBM.



Although not all the rooms or materials (non-suspect) were sampled, the like materials that were not tested and their results will be treated as homogeneous. The materials will be treated as containing LBM throughout the site.

The locations and results of the suspect samples found to be LBM are as follows:

John Sloat ES

Sample ID:	Sample Location Description	Structure	Color	Lead (mg/cm ²)
7525-1L	Girl's Restroom Walls, Tiles	Ceramic	Yellow	9.3
7525-2L	Boy's Restroom Walls, Tiles	Ceramic	Blue	12.7

Tahoe ES

Sample ID:	Sample Location Description	Structure	Color	Lead (mg/cm ²)
3110-1L	Girl's Restroom Walls, Tiles	Ceramic	Tan	12.3
3110-2L	Boy's Restroom Walls, Tiles	Ceramic	Multi	12.3

Before the renovation/demolition work is completed or the transporting of the debris from the site, Health, and Safety Code 25157.8 (AB 2784 National Resources) requires that all lead debris be sampled for Waste Characterization. This will help the Contractor decide whether the material is to be considered Hazardous or Non-Hazardous Lead waste or general construction debris. The sequence of testing to be completed by the Contractor is as follows:

- Total Threshold Limit Concentration (TTLC) resulting from 50 mg/kg or more, but less than 1,000 mg/kg of lead must be retested using the Soluble Threshold Limit concentration (STLC) method.
- An STLC result of 5.0 mg/L or greater is considered California Hazardous Waste.
- Total Characteristic Leaching Procedure (TCLP) testing shall only be accomplished when approved by the Owners Representative; This procedure shall be generally reserved for out-of-state shipments, and A TCLP result of 5.0 mg/L or more deems the waste Federal RCRA materials; and
- The California hazardous waste threshold for total lead using STLC is 5 mg/L.

The following were found to be less than (<) Cal-OSHA's Limit of Detection:

Alice Birney K-8

Sample ID:	Sample Location Description	Structure	Lead (mg/cm ²)
6251-1L	Interior Walls, White Paint	Sheetrock	<LOD
6251-2L	Interior Doors, Frames, & Trim, Orange Paint	Metal	<LOD

John Bidwell ES

Sample ID:	Sample Location Description	Structure	Lead (mg/cm ²)
1730-1L	Interior Walls, Multi-Colored Tiles	Ceramic	<LOD
1730-2L	Interior Walls, White Paint	Sheetrock	<LOD
1730-3L	Interior Ceiling, White Paint	Wood	<LOD



Sample ID:	Sample Location Description	Structure	Lead (mg/cm ²)
1730-4L	Interior Floors, Tan Tiles	Ceramic	<LOD
1730-5L	Interior Doors, Frames, & Trim, Blue Paint	Metal	<LOD

John Sloat ES

Sample ID:	Sample Location Description	Structure	Lead (mg/cm ²)
7525-3L	Girl's Restroom Floor, Yellow Tiles	Ceramic	<LOD
7525-4L	Boy's Restroom Floor, Blue Tiles	Ceramic	<LOD
7525-5L	Staff Restroom Walls, Multi-Colored Tiles	Ceramic	<LOD
7525-6L	Staff Restroom Floor, Tan Tiles	Ceramic	<LOD
7525-7L	Interior Walls, White Paint	Sheetrock	<LOD
7525-8L	Interior Ceiling, White Paint	Wood	<LOD
7525-9L	Interior Doors, Blue Paint	Metal	<LOD
7525-10L	Interior Frames/Trim, Blue Paint	Wood	<LOD

Joseph Bonnheim ES

Sample ID:	Sample Location Description	Structure	Lead (mg/cm ²)
7300-1L	Interior Doors, Frames, & Trim, Blue Paint	Metal	<LOD

Tahoe ES

Sample ID:	Sample Location Description	Structure	Lead (mg/cm ²)
3110-3L	Staff Restroom Walls/Ceiling, Tan Paint	Sheetrock	<LOD
3110-4L	Staff Restroom, Doors, Frames, & Trim, Tan Paint	Metal	<LOD
3110-5L	Boy's Restroom Walls/Ceiling, Tan Paint	Sheetrock	<LOD
3110-6L	Girl's Restroom Walls/Ceiling, Tan Paint	Sheetrock	<LOD
3110-7L	Boy's Restroom, Doors, Frames, & Trim, Blue Paint	Metal	<LOD
3110-8L	Boy's Restroom Floor, Blue Tiles	Ceramic	<LOD
3110-9L	Girl's Restroom, Doors, Frames, & Trim, Blue Paint	Metal	<LOD
3110-10L	Girl's Restroom Floor, Green Tiles	Ceramic	<LOD

LEAD RECOMMENDATION -

To stabilize the current lead conditions, N.A.L recommends Lead Certified CDPH Workers conduct in-place management work of the LBM surfaces/sample scheduled for renovation/demolition. Once the abatement, in-place management, or prep work is completed and the areas are stabilized, the existing surfaces/samples will be in good condition and not create a health or safety concern to the workers conducting the general



construction work at the site. A Scope of Work or specifications should be utilized to conduct the lead work at the site.

ASSUMPTIONS AND LIMITATIONS -

The results, findings, conclusions, and recommendations expressed in this report are based only on conditions noted during N.A.L.'s inspection of the specific areas listed herein.

The selection of sample locations and sampling frequency was based on observations and the assumption that like materials in the same area are homogeneous in content. This report is not to be utilized as a bidding document or a project specification document since it does not have all the components required to serve as an Asbestos & Lead Abatement Project Design document or an Asbestos and Lead Abatement Work plan.

Our professional services have been performed, our findings obtained, and our conclusions and recommendations prepared following established principles and practices in environmental testing and consulting. This report does not warrant undiscovered hazards and locations not investigated.

This report includes the laboratory analytical results, chain custody forms, and sample location map. If you have any questions regarding this report or can be of further assistance, please get in touch with our office.

Reviewed and submitted by:



Michael J. Lee
Certified Asbestos Consultant
DOSH# 06-4047
Certified Lead Inspector/Assessor
LRC-00007541
Registered Environmental Property Assessor
REPA# 716352750

Conducted by:



Robert Mullen
Certified Site Surveillance Technician
DOSH# 17-5889
Certified Lead Sampling Technician
CDPH# 28631





MicroTest Laboratories Inc. NVLAP Code: 200999-0
 3110 Gold Canal Dr. Ste. A. Rancho Cordova, CA 95670
 PH 916.567.9808 | FX 916.404.0302
 www.microtestlabsinc.com | service@microtestlabsinc.com

Project ID
MT012219533

CLIENT INFORMATION

Company National Analytical Laboratories, Inc.
Name Paula Lee
Address 2201 Francisco Drive, Ste. 140-261
 El Dorado Hills CA, 95762
Phone (916) 361 - 0555
Email N.A.L. Distribution List

SAMPLE

Date Friday, May 06, 2022
Time 8:00 AM

JOB SITE INFORMATION

Sampler Robert Mullen
Project Alice Birney Public School
Address 6251 13th Street
 Sacramento, CA 95831



POLARIZED LIGHT MICROSCOPY (PLM)

EPA METHOD 600 / R-93 / 116 & EPA – 40 CFR Appendix E to Subpart E of Part 763

Sample ID	Accession Number	Client Description	Laboratory Description	Non Fibrous / Fibrous Materials	Asbestiform Minerals %
6251-1	19533-1	Girls Restroom Ceiling	White/Yellow Ceiling Tile Fibrous Homogenous	90% Fiberglass 10% Binder	None Detected
6251-2A	19533-2	Girls Restroom, Damage, Multicolor	Tan Linoleum Non-Fibrous Homogenous	100% Binder	None Detected
6251-2B	19533-3	Girls Restroom, Damage	Yellow Mastic Non-Fibrous Homogenous	100% Binder	None Detected
6251-3A	19533-4	Girls Restroom, Damage	White Texture Non-Fibrous Homogenous	100% Binder	None Detected
6251-3B	19533-5	Boys Restroom, Light Switch	White Texture Non-Fibrous Homogenous	100% Binder	None Detected
6251-3C	19533-6	Staff Restroom, Light Switch	White Texture Non-Fibrous Homogenous	100% Binder	None Detected

Report

Date Friday, May 06, 2022

Samples Received: 7
Samples Analyzed: 7

Analyst: Nolan Starbuck

Authorized Signatory:

Kelly Favero - Lab Manager

This analytical data sheet constitutes a final report. Due to the limitation of Polarized Light Microscopy (PLM), some samples classified as containing no asbestos in materials, NoneDetected (ND), such as floor tiles or like materials, warrant a recommendation for further analysis by Transmission Electron Microscopy (TEM). Results apply to the sample as received. This report must not be used by the client to claim product endorsement by NVLAP or any agency of the U.S. Government. All Samples will be held for not less than 30 days, upon which they will then be disposed of. This report shall not be reproduced in full without written authorization from MicroTest Laboratories, Inc. Soil and rock matrices are considered problematic matrices and MicroTest recommends sample homogenization prior to PLM analysis. Thermal decomposition of asbestos fibers can yield non-asbestiform mineral properties. The reporting limit for calibrated visual area estimation quantitation procedures is 1%. The reporting limit for 400/1000 point count quantitation procedures is 0.25% or 0.1% respectively. The sample is considered acceptable unless otherwise noted. Sub-samples are analyzed separately accept when manufactured with multiple layers (i.e. Linoluem, Drywall, etc.) or requested contrarily by the client



Project ID
 MT012219533

CLIENT INFORMATION

Company Sac City Unified School District
Name Mike Taxara
Address 425 First Avenue
 Sacramento CA, 95818
Phone (916) 395 - 3980
Email Tina-Alvarez-Bevens@scusd.edu

Sample
Date Friday, May 06, 2022
Time 08:00 AM

Chain-Of-Custody

JOB SITE INFORMATION

Site Alice Birney Public School
Address 6251 13th Street
 Sacramento, CA 95831
Unit
Claim#
Job # 41702
Chain # 1

Analysis: PLM | TTFP - 400 PT.CT.

Turn Around Time: Same Day

Sample Number:	Location	Description
6251-1	Girls Restroom Ceiling	Acoustic Ceiling Tile
6251-2A	Girls Restroom, Damage, Multicolor	Linoleum
6251-2B	Girls Restroom, Damage	Mastic
6251-3A	Girls Restroom, Damage	Texture
6251-3B	Boys Restroom, Light Switch	Texture
6251-3C	Staff Restroom, Light Switch	Texture
6251-4	Girls Restroom, Damage	Sheetrock-Joint Compound

Relinquished by (Client)	Date/Time

Received by (Tech)	Date/Time

Relinquished by (Tech)	Date/Time
	05/06/2022 08:00 AM

Received by (Lab)	Date/Time
	05/06/2022 2:20 PM

Sampler: Robert Mullen

Total Number of Samples 7



PH 916.361.0555 | FX 916.361.0540
 service@nall.com

KS#
 Client PO
 Project ID

for office use only

CLIENT INFORMATION

Company Sac City Unified School District
Name Mike Taxara
Address 425 First Avenue
 Sacramento CA, 95818
Phone (916) 395 - 3980
Email

SAMPLE

Date Friday, May 06, 2022
Time 08:00 AM

Chain-Of-Custody | Analytical Data
 Heuresis Pb200i

JOB SITE INFORMATION

Site Alice Birney Public School
Address 6251 13th Street
 Sacramento, CA 95831
Unit
Claim#
Job # 26269
Chain # 1

TURN AROUND	LEAD PAINT	MEASUREMENT MODE	SAMPLING METHOD	ANALYTICAL DATA
Same Day	Inspection	Standard	Heuresis Pb200i	Action Level - 1 Abatement Level - 1 Total Readings - 2

Sample ID:	Sample Location Description	Structure Material	Color	Condition	Lead (mg/cm ²)
6251-1L	Interior Walls, Paint	Sheetrock	White	N/A	<LOD
6251-2L	Interior Doors, Frames, & Trim, Paint	Metal	Orange	N/A	<LOD



MicroTest Laboratories Inc. NVLAP Code: 200999-0
 3110 Gold Canal Dr. Ste. A. Rancho Cordova, CA 95670
 PH 916.567.9808 | FX 916.404.0302
 www.microtestlabsinc.com | service@microtestlabsinc.com

Project ID
MT012219534

CLIENT INFORMATION

Company National Analytical Laboratories, Inc.
Name Paula Lee
Address 2201 Francisco Drive, Ste. 140-261
 El Dorado Hills CA, 95762
Phone (916) 361 - 0555
Email N.A.L. Distribution List

SAMPLE

Date Friday, May 06, 2022
Time 9:00 AM

JOB SITE INFORMATION

Sampler Robert Mullen
Project Address John Bidwell Elementary School Property
 1730 65th Avenue
 Sacramento, CA 95822



POLARIZED LIGHT MICROSCOPY (PLM)

EPA METHOD 600 / R-93 / 116 & EPA – 40 CFR Appendix E to Subpart E of Part 763

Sample ID	Accession Number	Client Description	Laboratory Description	Non Fibrous / Fibrous Materials	Asbestiform Minerals %
1730-1A	19534-1	Girls Restroom, Damage	White Texture Non-Fibrous Homogenous	100% Binder	None Detected
1730-1B	19534-2	Boys Restroom, Damage	White Texture Non-Fibrous Homogenous	100% Binder	None Detected
1730-1C	19534-3	Staff Restroom, Damage	White Texture Non-Fibrous Homogenous	100% Binder	None Detected
1730-2	19534-4	Girls Restroom, Damage	White Sheetrock-Joint Compound Non-Fibrous Homogenous	100% Binder	None Detected

Report

Date Friday, May 06, 2022

Samples Received: 4
Samples Analyzed: 4

Analyst: Nolan Starbuck

Authorized Signatory:

Kelly Favero - Lab Manager

This analytical data sheet constitutes a final report. Due to the limitation of Polarized Light Microscopy (PLM), some samples classified as containing no asbestos in materials, NoneDetected (ND), such as floor tiles or like materials, warrant a recommendation for further analysis by Transmission Electron Microscopy (TEM). Results apply to the sample as received. This report must not be used by the client to claim product endorsement by NVLAP or any agency of the U.S. Government. All Samples will be held for not less than 30 days, upon which they will then be disposed of. This report shall not be reproduced in full without written authorization from MicroTest Laboratories, Inc. Soil and rock matrices are considered problematic matrices and MicroTest recommends sample homogenization prior to PLM analysis. Thermal decomposition of asbestos fibers can yield non-asbestiform mineral properties. The reporting limit for calibrated visual area estimation quantitation procedures is 1%. The reporting limit for 400/1000 point count quantitation procedures is 0.25% or 0.1% respectively. The sample is considered acceptable unless otherwise noted. Sub-samples are analyzed separately accept when manufactured with multiple layers (i.e. Linoluem, Drywall, etc.) or requested contrarily by the client



Project ID
 MT012219534

CLIENT INFORMATION

Company Sac City Unified School District
Name Mike Taxara
Address 425 First Avenue
 Sacramento CA, 95818
Phone (916) 395 - 3980
Email Tina-Alvarez-Bevens@scusd.edu

Sample
Date Friday, May 06, 2022
Time 09:00 AM

Chain-Of-Custody

JOB SITE INFORMATION

Site John Bidwell Elementary School Property
Address 1730 65th Avenue
 Sacramento, CA 95822
Unit
Claim#
Job # 41703
Chain # 1

Analysis: PLM | TTFP - 400 PT.CT.

Turn Around Time: Same Day

Sample Number:	Location	Description
1730-1A	Girls Restroom, Damage	Texture
1730-1B	Boys Restroom, Damage	Texture
1730-1C	Staff Restroom, Damage	Texture
1730-2	Girls Restroom, Damage	Sheetrock-Joint Compound

Relinquished by (Client)	Date/Time

Received by (Tech)	Date/Time

Relinquished by (Tech)	Date/Time
	05/06/2022 09:00 AM

Received by (Lab)	Date/Time
	05/06/2022 2:19 PM

Sampler: Robert Mullen

Total Number of Samples 4



PH 916.361.0555 | FX 916.361.0540
 service@nall.com

KS#
 Client PO
 Project ID

for office use only

CLIENT INFORMATION

Company Sac City Unified School District
Name Mike Taxara
Address 425 First Avenue
 Sacramento CA, 95818
Phone (916) 395 - 3980
Email

SAMPLE

Date Friday, May 06, 2022
Time 08:00 AM

Chain-Of-Custody | Analytical Data
 Heuresis Pb200i

JOB SITE INFORMATION

Site Alice Birney Public School
Address 6251 13th Street
 Sacramento, CA 95831
Unit
Claim#
Job # 26269
Chain # 1

TURN AROUND	LEAD PAINT	MEASUREMENT MODE	SAMPLING METHOD	ANALYTICAL DATA
Same Day	Inspection	Standard	Heuresis Pb200i	Action Level - 1 Abatement Level - 1 Total Readings - 2

Sample ID:	Sample Location Description	Structure Material	Color	Condition	Lead (mg/cm ²)
6251-1L	Interior Walls, Paint	Sheetrock	White	N/A	<LOD
6251-2L	Interior Doors, Frames, & Trim, Paint	Metal	Orange	N/A	<LOD



MicroTest Laboratories Inc. NVLAP Code: 200999-0
 3110 Gold Canal Dr. Ste. A. Rancho Cordova, CA 95670
 PH 916.567.9808 | FX 916.404.0302
 www.microtestlabsinc.com | service@microtestlabsinc.com

Project ID
MT012219535

CLIENT INFORMATION

Company National Analytical Laboratories, Inc.

Name Paula Lee

Address 2201 Francisco Drive, Ste. 140-261
 El Dorado Hills CA, 95762

Phone (916) 361 - 0555

Email N.A.L. Distribution List

SAMPLE

Date Friday, May 06, 2022

Time 10:00 AM

MicroTest
Laboratories
Analytical Data

JOB SITE INFORMATION

Sampler Robert Mullen

Project John Sloat Elementary School

Address 7525 Candlewood Way
 Sacramento, CA 95822

POLARIZED LIGHT MICROSCOPY (PLM)

EPA METHOD 600 / R-93 / 116 & EPA – 40 CFR Appendix E to Subpart E of Part 763

Sample ID	Accession Number	Client Description	Laboratory Description	Non Fibrous / Fibrous Materials	Asbestiform Minerals %
7525-1A	19535-1	Girls Restroom, Damage	White Plaster Fibrous Homogenous	5% Cellulose 95% Binder	None Detected
7525-1B	19535-2	Boys Restroom, Damage	White Plaster Fibrous Homogenous	5% Cellulose 95% Binder	None Detected
7525-1C	19535-3	Staff Restroom, Damage	White Plaster Fibrous Homogenous	5% Cellulose 95% Binder	None Detected

Report

Date Friday, May 06, 2022

Samples Received: 3
Samples Analyzed: 3

Analyst: Nolan Starbuck

Authorized Signatory:

Kelly Favero - Lab Manager

This analytical data sheet constitutes a final report. Due to the limitation of Polarized Light Microscopy (PLM), some samples classified as containing no asbestos in materials, NoneDetected (ND), such as floor tiles or like materials, warrant a recommendation for further analysis by Transmission Electron Microscopy (TEM). Results apply to the sample as received. This report must not be used by the client to claim product endorsement by NVLAP or any agency of the U.S. Government. All Samples will be held for not less than 30 days, upon which they will then be disposed of. This report shall not be reproduced in full without written authorization from MicroTest Laboratories, Inc. Soil and rock matrices are considered problematic matrices and MicroTest recommends sample homogenization prior to PLM analysis. Thermal decomposition of asbestos fibers can yield non-asbestiform mineral properties. The reporting limit for calibrated visual area estimation quantitation procedures is 1%. The reporting limit for 400/1000 point count quantitation procedures is 0.25% or 0.1% respectively. The sample is considered acceptable unless otherwise noted. Sub-samples are analyzed separately accept when manufactured with multiple layers (i.e. Linoluem, Drywall, etc.) or requested contrarily by the client



Project ID
MT012219535

CLIENT INFORMATION

Company Sac City Unified School District
Name Mike Taxara
Address 425 First Avenue
Sacramento CA, 95818
Phone (916) 395 - 3980
Email Tina-Alvarez-Bevens@scusd.edu

Sample
Date Friday, May 06, 2022
Time 10:00 AM

Chain-Of-Custody

JOB SITE INFORMATION

Site John Sloat Elementary School
Address 7525 Candlewood Way
Sacramento, CA 95822
Unit
Claim#
Job # 41704
Chain # 1

Analysis: PLM | TTFP - 400 PT.CT.

Turn Around Time: Same Day

Sample Number:	Location	Description
7525-1A	Girls Restroom, Damage	Plaster
7525-1B	Boys Restroom, Damage	Plaster
7525-1C	Staff Restroom, Damage	Plaster

Relinquished by (Client)	Date/Time

Relinquished by (Tech)	Date/Time
	05/06/2022 10:00 AM

Sampler: Robert Mullen

Received by (Tech)	Date/Time

Received by (Lab)	Date/Time
	05/06/2022 2:19 PM

Total Number of Samples 3



PH 916.361.0555 | FX 916.361.0540
service@nall.com

for office use only
KS#
Client PO
Project ID

CLIENT INFORMATION

Company Sac City Unified School District
Name Mike Taxara
Address 425 First Avenue
Sacramento CA, 95818
Phone (916) 395 - 3980
Email

SAMPLE
Date Friday, May 06, 2022
Time 10:00 AM

Chain-Of-Custody | Analytical Data
Heuresis Pb200i

JOB SITE INFORMATION

Site John Sloat Elementary School
Address 7525 Candlewood Way
Sacramento, CA 95822
Unit
Claim#
Job # 26271
Chain # 1

TURN AROUND Same Day
LEAD PAINT Inspection
MEASUREMENT MODE Standard
SAMPLING METHOD Heuresis Pb200i
ANALYTICAL DATA Action Level - 1
Abatement Level - 1
Total Readings - 10

Sample ID:	Sample Location Description	Structure Material	Color	Condition	Lead (mg/cm ²)
7525-1L	Girl's Restroom Walls, Tiles	Ceramic	Yellow	Intact	9.3
7525-2L	Boy's Restroom Walls, Tiles	Ceramic	Blue	Intact	12.7
7525-3L	Girl's Restroom Floor, Tiles	Ceramic	Yellow	N/A	<LOD
7525-4L	Boy's Restroom Floor, Tiles	Ceramic	Blue	N/A	<LOD
7525-5L	Staff Restroom Walls, Tiles	Ceramic	Multi	N/A	<LOD
7525-6L	Staff Restroom Floor, Tiles	Ceramic	Tan	N/A	<LOD
7525-7L	Interior Walls, Paint	Sheetrock	White	N/A	<LOD
7525-8L	Interior Ceiling, Paint	Wood	White	N/A	<LOD
7525-9L	Interior Doors, Paint	Metal	Blue	N/A	<LOD

<LOD Below Limit of Detection | Reading < 0.0

LCM Lead Containing Material | Readings Ranging from 0 to < 1.0 mg/cm²

LBP Lead Based Paint | Readings Greater than 1.0 mg/cm²

ANALYSIS

Date May 06, 2022
Time 10:00 AM

California Dept. of Public Health
www.2.epa.gov/lead



Relinquished by (Client)	Date/Time

Relinquished by (Tech)	Date/Time
	05/06/2022 10:00 AM

Sampler: Robert Mullen

Analyst: Robert Mullen

Received by (Tech)	Date/Time

Received by (Lab)	Date/Time
	05/06/2022 10:00 AM

Total Number of Samples 10



MicroTest Laboratories Inc. NVLAP Code: 200999-0
 3110 Gold Canal Dr. Ste. A. Rancho Cordova, CA 95670
 PH 916.567.9808 | FX 916.404.0302
 www.microtestlabsinc.com | service@microtestlabsinc.com

Project ID

MT012219536

CLIENT INFORMATION

Company National Analytical Laboratories, Inc.

Name Paula Lee

Address 2201 Francisco Drive, Ste. 140-261
 El Dorado Hills CA, 95762

Phone (916) 361 - 0555

Email N.A.L. Distribution List

SAMPLE

Date Friday, May 06, 2022

Time 11:00 AM

JOB SITE INFORMATION

Sampler Robert Mullen

Project New Joseph Bonnheim Elementary School Property

Address 7300 Marin Avenue

Sacramento, CA 95820



Analytical Data

POLARIZED LIGHT MICROSCOPY (PLM)

EPA METHOD 600 / R-93 / 116 & EPA – 40 CFR Appendix E to Subpart E of Part 763

Sample ID	Accession Number	Client Description	Laboratory Description	Non Fibrous / Fibrous Materials	Asbestiform Minerals %
7300-1	19536-1	Boys Restroom Ceiling	White/Yellow Ceiling Tile Fibrous Homogenous	90% Fiberglass 10% Binder	None Detected

Report

Date Friday, May 06, 2022

Samples Received: 1
Samples Analyzed: 1

Analyst: Nolan Starbuck

Authorized Signatory:

Kelly Favero - Lab Manager

This analytical data sheet constitutes a final report. Due to the limitation of Polarized Light Microscopy (PLM), some samples classified as containing no asbestos in materials, NoneDetected (ND), such as floor tiles or like materials, warrant a recommendation for further analysis by Transmission Electron Microscopy (TEM). Results apply to the sample as received. This report must not be used by the client to claim product endorsement by NVLAP or any agency of the U.S. Government. All Samples will be held for not less than 30 days, upon which they will then be disposed of. This report shall not be reproduced in full without written authorization from MicroTest Laboratories, Inc. Soil and rock matrices are considered problematic matrices and MicroTest recommends sample homogenization prior to PLM analysis. Thermal decomposition of asbestos fibers can yield non-asbestiform mineral properties. The reporting limit for calibrated visual area estimation quantitation procedures is 1%. The reporting limit for 400/1000 point count quantitation procedures is 0.25% or 0.1% respectively. The sample is considered acceptable unless otherwise noted. Sub-samples are analyzed separately accept when manufactured with multiple layers (i.e. Linoluem, Drywall, etc.) or requested contrarily by the client



Project ID
 MT012219536

CLIENT INFORMATION

Company Sac City Unified School District
Name Mike Taxara
Address 425 First Avenue
 Sacramento CA, 95818
Phone (916) 395 - 3980
Email Tina-Alvarez-Bevens@scusd.edu

Sample
Date Friday, May 06, 2022
Time 11:00 AM

Chain-Of-Custody

JOB SITE INFORMATION

Site New Joseph Bonnheim Elementary School Property
Address 7300 Marin Avenue
 Sacramento, CA 95820
Unit
Claim#
Job # 41705
Chain # 1

Analysis: PLM | TTFP - 400 PT.CT.
Turn Around Time: Same Day

Sample Number:	Location	Description
7300-1	Boys Restroom Ceiling	Acoustic Ceiling Tile

Relinquished by (Client)	Date/Time

Received by (Tech)	Date/Time

Relinquished by (Tech)	Date/Time
	05/06/2022 11:00 AM

Received by (Lab)	Date/Time
	05/06/2022 2:19 PM

Sampler: Robert Mullen

Total Number of Samples 1



KS#
Client PO
Project ID

for office use only

CLIENT INFORMATION

Company Sac City Unified School District
Name Mike Taxara
Address 425 First Avenue
Sacramento CA, 95818
Phone (916) 395 - 3980
Email

SAMPLE

Date Friday, May 06, 2022
Time 11:00 AM

Chain-Of-Custody | Analytical Data

Heuresis Pb200i

JOB SITE INFORMATION

Site New Joseph Bonnheim Elementary School Property
Address 7300 Marin Avenue
Sacramento, CA 95820
Unit
Claim#
Job # 26272
Chain # 1

TURN AROUND Same Day	LEAD PAINT Inspection	MEASUREMENT MODE Standard	SAMPLING METHOD Heuresis Pb200i	ANALYTICAL DATA Action Level - 1 Abatement Level - 1 Total Readings - 1
--------------------------------	---------------------------------	-------------------------------------	---	---

Sample ID:	Sample Location Description	Structure Material	Color	Condition	Lead (mg/cm ²)
7300-1L	Interior Doors, Frames, & Trim, Paint	Metal	Blue	N/A	<LOD

<LOD Below Limit of Detection | Reading < 0.0

LCM Lead Containing Material | Readings Ranging from 0 to < 1.0 mg/cm²

LBP Lead Based Paint | Readings Greater than 1.0 mg/cm²

ANALYSIS

Date	May 06, 2022
Time	11:00 AM

California Dept. of Public Health
www.2.epa.gov/lead



Sampler: Robert Mullen

Analyst: Robert Mullen

Total Number of Samples 1

Relinquished by (Client)	Date/Time

Relinquished by (Tech)	Date/Time
	05/06/2022 11:00 AM

Received by (Tech)	Date/Time

Received by (Lab)	Date/Time
	05/06/2022 11:00 AM



MicroTest Laboratories Inc. NVLAP Code: 200999-0
 3110 Gold Canal Dr. Ste. A. Rancho Cordova, CA 95670
 PH 916.567.9808 | FX 916.404.0302
 www.microtestlabsinc.com | service@microtestlabsinc.com

Project ID
MT012219537

CLIENT INFORMATION

Company National Analytical Laboratories, Inc.
Name Paula Lee
Address 2201 Francisco Drive, Ste. 140-261
 El Dorado Hills CA, 95762
Phone (916) 361 - 0555
Email N.A.L. Distribution List

SAMPLE

Date Friday, May 06, 2022

Time 11:30 AM



JOB SITE INFORMATION

Sampler Robert Mullen
Project Tahoe Elementary School
Address 3110 60th Street
 Sacramento, CA 95820

POLARIZED LIGHT MICROSCOPY (PLM)

EPA METHOD 600 / R-93 / 116 & EPA – 40 CFR Appendix E to Subpart E of Part 763

Sample ID	Accession Number	Client Description	Laboratory Description	Non Fibrous / Fibrous Materials	Asbestiform Minerals %
3110-1A	19537-1	Staff Restroom, Damage	White Texture Non-Fibrous Homogenous	100% Binder	None Detected
3110-1B	19537-2	Boys Restroom, Damage	White Texture Non-Fibrous Homogenous	100% Binder	None Detected
3110-1C	19537-3	Girls Restroom, Damage	White Texture Non-Fibrous Homogenous	100% Binder	None Detected
3110-2	19537-4	Staff Restroom, Damage	White Sheetrock-Joint Compound Fibrous Heterogenous	10% Cellulose 90% Binder	None Detected
3110-3A	19537-5	Staff Restroom, Damage, Multicolor	Gray Tile Non-Fibrous Homogenous	100% Binder	None Detected
3110-3B	19537-6	Staff Restroom, Damage	Black Mastic Non-Fibrous Homogenous	100% Binder	None Detected

Report

Date Friday, May 06, 2022

Samples Received: 7
Samples Analyzed: 7

Analyst: Nolan Starbuck

Authorized Signatory:

Kelly Favero - Lab Manager

This analytical data sheet constitutes a final report. Due to the limitation of Polarized Light Microscopy (PLM), some samples classified as containing no asbestos in materials, NoneDetected (ND), such as floor tiles or like materials, warrant a recommendation for further analysis by Transmission Electron Microscopy (TEM). Results apply to the sample as received. This report must not be used by the client to claim product endorsement by NVLAP or any agency of the U.S. Government. All Samples will be held for not less than 30 days, upon which they will then be disposed of. This report shall not be reproduced in full without written authorization from MicroTest Laboratories, Inc. Soil and rock matrices are considered problematic matrices and MicroTest recommends sample homogenization prior to PLM analysis. Thermal decomposition of asbestos fibers can yield non-asbestiform mineral properties. The reporting limit for calibrated visual area estimation quantitation procedures is 1%. The reporting limit for 400/1000 point count quantitation procedures is 0.25% or 0.1% respectively. The sample is considered acceptable unless otherwise noted. Sub-samples are analyzed separately accept when manufactured with multiple layers (i.e. Linoluem, Drywall, etc.) or requested contrarily by the client



MicroTest Laboratories Inc. NVLAP Code: 200999-0
 3110 Gold Canal Dr. Ste. A. Rancho Cordova, CA 95670
 PH 916.567.9808 | FX 916.404.0302
 www.microtestlabsinc.com | service@microtestlabsinc.com

Project ID
MT012219537

3110-4 19537-7 Staff Restroom, Damage

Cream Mastic
 Non-Fibrous
 Homogenous

100% Binder None Detected

Report	
Date	Friday, May 06, 2022

Samples Received: 7
Samples Analyzed: 7

Analyst: Nolan Starbuck

Authorized Signatory:

Kelly Favero - Lab Manager

This analytical data sheet constitutes a final report. Due to the limitation of Polarized Light Microscopy (PLM), some samples classified as containing no asbestos in materials, NoneDetected (ND), such as floor tiles or like materials, warrant a recommendation for further analysis by Transmission Electron Microscopy (TEM). Results apply to the sample as received. This report must not be used by the client to claim product endorsement by NVLAP or any agency of the U.S. Government. All Samples will be held for not less than 30 days, upon which they will then be disposed of. This report shall not be reproduced in full without written authorization from MicroTest Laboratories, Inc. Soil and rock matrices are considered problematic matrices and MicroTest recommends sample homogenization prior to PLM analysis. Thermal decomposition of asbestos fibers can yield non-asbestiform mineral properties. The reporting limit for calibrated visual area estimation quantitation procedures is 1%. The reporting limit for 400/1000 point count quantitation procedures is 0.25% or 0.1% respectively. The sample is considered acceptable unless otherwise noted. Sub-samples are analyzed separately accept when manufactured with multiple layers (i.e. Linoluem, Drywall, etc.) or requested contrarily by the client



Project ID
MT012219537

CLIENT INFORMATION

Company Sac City Unified School District
Name Mike Taxara
Address 425 First Avenue
Sacramento CA, 95818
Phone (916) 395 - 3980
Email Tina-Alvarez-Bevens@scusd.edu

Sample
Date Friday, May 06, 2022
Time 11:30 AM

Chain-Of-Custody

JOB SITE INFORMATION

Site Tahoe Elementary School
Address 3110 60th Street
Sacramento, CA 95820
Unit
Claim#
Job # 41706
Chain # 1

Analysis: PLM | TTFP - 400 PT.CT.

Turn Around Time: Same Day

Sample Number:	Location	Description
3110-1A	Staff Restroom, Damage	Texture
3110-1B	Boys Restroom, Damage	Texture
3110-1C	Girls Restroom, Damage	Texture
3110-2	Staff Restroom, Damage	Sheetrock-Joint Compound
3110-3A	Staff Restroom, Damage, Multicolor	Floor Tile
3110-3B	Staff Restroom, Damage	Mastic
3110-4	Staff Restroom, Damage	Cove Base Mastic

Relinquished by (Client)	Date/Time

Received by (Tech)	Date/Time

Relinquished by (Tech)	Date/Time
	05/06/2022 11:30 AM

Received by (Lab)	Date/Time
	05/06/2022 2:19 PM

Sampler: Robert Mullen

Total Number of Samples 7



PH 916.361.0555 | FX 916.361.0540
service@nall.com

for office use only
KS#
Client PO
Project ID

CLIENT INFORMATION

Company Sac City Unified School District
Name Mike Taxara
Address 425 First Avenue
Sacramento CA, 95818
Phone (916) 395 - 3980
Email

SAMPLE

Date Friday, May 06, 2022
Time 11:30 AM
Chain-Of-Custody | Analytical Data
Heuresis Pb200i

JOB SITE INFORMATION

Site Tahoe Elementary School
Address 3110 60th Street
Sacramento, CA 95820
Unit
Claim#
Job # 26273
Chain # 1

TURN AROUND Same Day **LEAD PAINT** Inspection **MEASUREMENT MODE** Standard **SAMPLING METHOD** Heuresis Pb200i **ANALYTICAL DATA** Action Level - 1
Abatement Level - 1
Total Readings - 10

Sample ID:	Sample Location Description	Structure Material	Color	Condition	Lead (mg/cm ²)
3110-1L	Girl's Restroom Walls, Tiles	Ceramic	Tan	Intact	12.3
3110-2L	Boy's Restroom Walls, Tiles	Ceramic	Multi	Intact	12.3
3110-3L	Staff Restroom Walls/Ceiling, Paint	Sheetrock	Tan	N/A	<LOD
3110-4L	Staff Restroom, Doors, Frames, & Trim, Paint	Metal	Tan	N/A	<LOD
3110-5L	Boy's Restroom Walls/Ceiling, Paint	Sheetrock	Tan	N/A	<LOD
3110-6L	Girl's Restroom Walls/Ceiling, Paint	Sheetrock	Tan	N/A	<LOD
3110-7L	Boy's Restroom, Doors, Frames, & Trim, Paint	Metal	Blue	N/A	<LOD
3110-8L	Boy's Restroom Floor, Tiles	Ceramic	Blue	N/A	<LOD

<LOD Below Limit of Detection | Reading < 0.0

LCM Lead Containing Material | Readings Ranging from 0 to < 1.0 mg/cm²

LBP Lead Based Paint | Readings Greater than 1.0 mg/cm²

ANALYSIS

Date May 06, 2022
Time 11:30 AM

California Dept. of Public Health
www.2.epa.gov/lead



Relinquished by (Client)	Date/Time

Relinquished by (Tech)	Date/Time
	05/06/2022 11:30 AM

Sampler: Robert Mullen

Analyst: Robert Mullen

Received by (Tech)	Date/Time

Received by (Lab)	Date/Time
	05/06/2022 11:30 AM

Total Number of Samples 10

Sample ID:	Sample Location Description	Structure Material	Color	Condition	Lead (mg/cm ²)
3110-9L	Girl's Restroom, Doors, Frames, & Trim, Paint	Metal	Blue	N/A	<LOD
3110-10L	Girl's Restroom Floor, Tiles	Ceramic	Green	N/A	<LOD

<LOD Below Limit of Detection | Reading < 0.0

LCM Lead Containing Material | Readings Ranging from 0 to < 1.0 mg/cm²

LBP Lead Based Paint | Readings Greater than 1.0 mg/cm²

ANALYSIS

Date	May 06, 2022
Time	11:30 AM

Relinquished by (Client)	Date/Time

Relinquished by (Tech)	Date/Time
	05/06/2022 11:30 AM

Received by (Tech)	Date/Time

Received by (Lab)	Date/Time
	05/06/2022 11:30 AM

California Dept. of Public Health
www.2.epa.gov/lead



Sampler: Robert Mullen

Analyst: Robert Mullen

Total Number of Samples 10

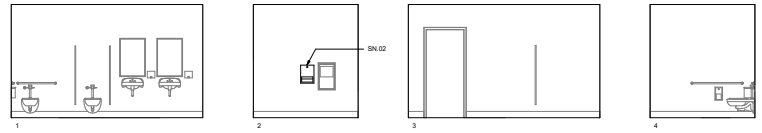

RR101 - GIRLS
1/4" = 1'-0"

ADULT HEIGHT

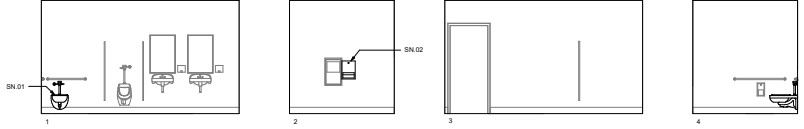

RR102 - BOYS
1/4" = 1'-0"

ADULT HEIGHT

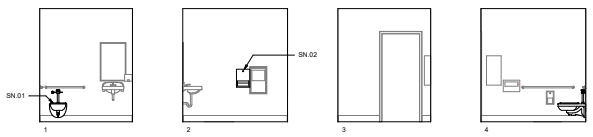

RR103 - STAFF
1/4" = 1'-0"

ADULT HEIGHT

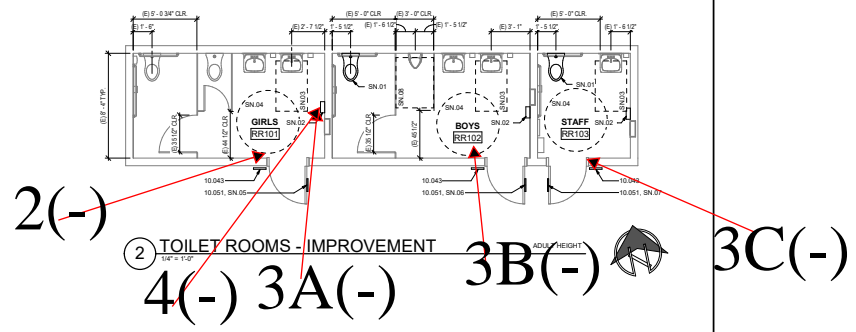

TOILET ROOMS - IMPROVEMENT
1/4" = 1'-0"

TOILET ROOMS - DEMOLITION
1/4" = 1'-0"

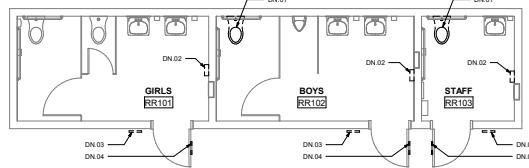

TOILET ROOMS - DEMOLITION
1/4" = 1'-0"

LEGEND



GENERAL NOTES

- FOR MOUNTING HEIGHTS, LOCATIONS, AND DETAILS, INCLUDING THOSE FOR DISABLED ACCESSIBILITY, REFER TO SHEET A&2.
- PROTECT ALL ADJACENT SURFACES, ITEMS AND FINISHES NOT NOTED TO BE DEMOLISHED.
- EQUIPMENT/FIXTURES NOTED AS "SALVAGED FOR REINSTALLATION" WILL BE REMOVED AND STORED BY THE CONTRACTOR PRIOR TO START OF DEMOLITION. THESE EQUIPMENT/FIXTURES SHALL BE REINSTALLED BY THE CONTRACTOR UNDER THIS CONTRACT.
- REMOVE ALL ITEMS SCHEDULED TO BE REMOVED, INCLUDING MOUNTING HARDWARE.
- DEMO AND REPAIR WALL FINISH AS NECESSARY TO PERFORM FIXTURE AND EQUIPMENT WORK AS NOTED. ADJACENT FINISHES TO BE VERIFIED BY CONTRACTOR.

DEMOLITION NOTES

- REMOVE (E) WALL-MOUNTED WATER CLOSET AND SALVAGE FOR REINSTALLATION.
- REMOVE (E) PAPER TOWEL DISPENSER AND SALVAGE FOR REINSTALLATION.
- REMOVE (E) TOILET ROOM I.D. SIGN.
- REMOVE (E) TOILET ROOM DOOR SYMBOL.

SHEET NOTES

- REINSTALL (E) SALVAGED WALL-MOUNTED WATER CLOSET TO COMPLY WITH A&2. ADJUST (E) WRITER CARRIER AS REQUIRED FOR RECONNECTION TO WATER CLOSET.
- RECONNECT (E) WATER LINE, WASTE LINE AND VENT.
- REINSTALL (E) SALVAGED PAPER TOWEL DISPENSER TO COMPLY WITH A&2.
- 30" X 48" CLEAR SPACE.
- 60" DIA. TURNING CIRCLE.
- SIGN TO READ "GIRLS".
- SIGN TO READ "BOYS".
- SIGN TO READ "STAFF".
- 30" X 48" CLEAR SPACE.

KEYNOTES

- 10.043 SIGNAGE: TOILET ROOM IDENTIFICATION
- 10.051 SIGNAGE: TOILET ROOM DOOR SYMBOL



SHADE STRUCTURE AT ALICE BIRNEY PUBLIC WALDORF K-8 SCHOOL

SACRAMENTO CITY UNIFIED SCHOOL DISTRICT
SACRAMENTO, CA

Revision

Copyright © 2021 Rankin-Gru Architects. All rights reserved. Reproduction of these plans, either in whole or in part, including any form of copying and/or preparation of duplicate works, hereby for any reason without prior written permission, is strictly prohibited.

TOILET ROOM DEMOLITION AND IMPROVEMENT PLANS AND INTERIOR ELEVATIONS

UNIT RR

PROJECT NO: 21-1894-01

DATE: 3/1/22

A2.1.1

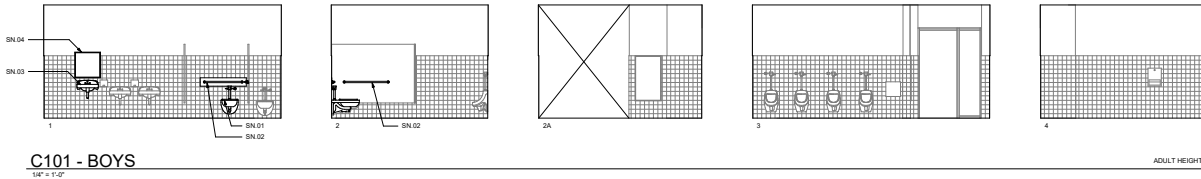

C101 - BOYS
1/4" = 1'-0"

ADULT HEIGHT

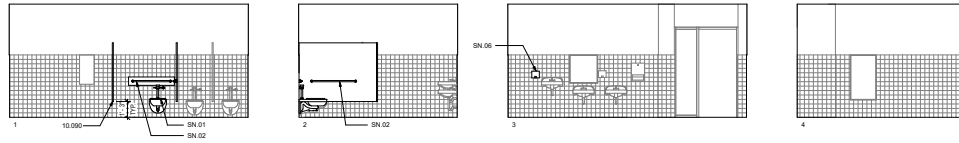

D101 - GIRLS
1/4" = 1'-0"

ADULT HEIGHT

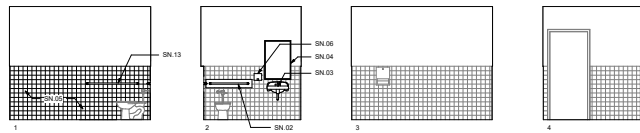

D102 - STAFF
1/4" = 1'-0"

ADULT HEIGHT

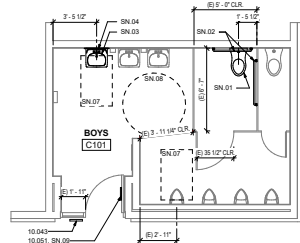

4 BOYS - IMPROVEMENT
1/4" = 1'-0"

ADULT HEIGHT

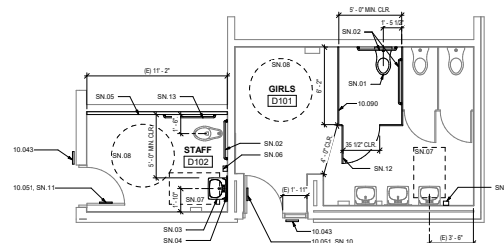

2 GIRLS AND STAFF - IMPROVEMENT
1/4" = 1'-0"

ADULT HEIGHT

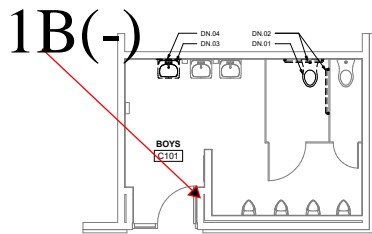

3 BOYS - DEMOLITION
1/4" = 1'-0"

ADULT HEIGHT

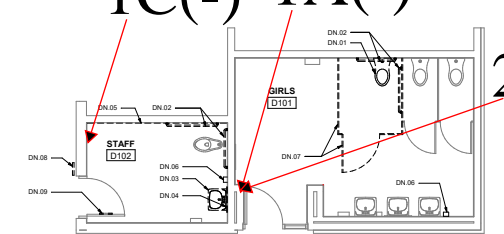

1 GIRLS AND STAFF - DEMOLITION
1/4" = 1'-0"

ADULT HEIGHT

LEGEND

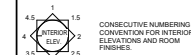

GENERAL NOTES

- FOR MOUNTING HEIGHTS, LOCATIONS, AND DETAILS, INCLUDING THOSE FOR DISABLED ACCESSIBILITY, REFER TO SHEET AD-2.
- PROTECT ALL ADJACENT SURFACES, ITEMS AND FINISHES NOT NOTED TO BE DEMOLISHED.
- EQUIPMENT/FIXTURES NOTED AS "SALVAGED FOR REINSTALLATION" WILL BE REMOVED AND STORED BY THE CONTRACTOR PRIOR TO START OF DEMOLITION. THESE EQUIPMENT/FIXTURES SHALL BE REINSTALLED BY THE CONTRACTOR UNDER THIS CONTRACT.
- REMOVE ALL ITEMS SCHEDULED TO BE REMOVED, INCLUDING MOUNTING HARDWARE.
- DEMO AND REPAIR WALL FINISH AS NECESSARY TO PERFORM FIXTURE AND EQUIPMENT WORK AS NOTED. ADJACENT FINISHES TO BE VERIFIED BY CONTRACTOR.

DEMOLITION NOTES

- REMOVE (E) WALL MOUNTED WATER CLOSET AND SALVAGE FOR REINSTALLATION
- REMOVE (E) GRAB BARS AND SALVAGE FOR REINSTALLATION
- REMOVE (E) LAVATORY AND SALVAGE FOR REINSTALLATION
- REMOVE (E) MIRROR AND SALVAGE FOR REINSTALLATION
- REMOVE (E) TILE FINISH FROM THIS WALL ONLY
- REMOVE (E) SOAP DISPENSER AND SALVAGE FOR REINSTALLATION
- REMOVE (E) TOILET PARTITION, SALVAGE (E) TOILET PARTITION DOOR FOR REINSTALLATION
- REMOVE (E) TOILET ROOM I.D. SIGN
- REMOVE (E) TOILET ROOM DOOR SYMBOL

SHEET NOTES

- REINSTALL (E) SALVAGED WALL MOUNTED WATER CLOSET TO COMPLY WITH AD-2. ADJUST (E) WATER CARRIER AS REQUIRED FOR RECONNECTION TO WATER CLOSET. RECONNECT TO (E) WATER LINE, WASTE LINE AND VENT.
- REINSTALL (E) SALVAGED GRAB BARS TO COMPLY WITH AD-2.
- REINSTALL (E) SALVAGED LAVATORY TO COMPLY WITH AD-2. ADJUST (E) WATER CARRIER AS REQUIRED FOR RECONNECTION TO LAVATORY. RECONNECT TO (E) WATER LINE, WASTE LINE AND VENT.
- REINSTALL (E) SALVAGED MIRROR TO COMPLY WITH AD-2.
- FURRED WALL PER (11) AD-2.
- REINSTALL (E) SALVAGED SOAP DISPENSER TO COMPLY WITH AD-2.
- 30" x 48" CLEAR SPACE
- 80" DIA. TURNING CIRCLE
- REMOVE (E) SIGN TO READ "BOYS"
- REMOVE (E) SIGN TO READ "GIRLS"
- REMOVE (E) SIGN TO READ "STAFF"
- REINSTALL (E) SALVAGED TOILET PARTITION DOOR
- REINSTALL (E) SALVAGED GRAB BAR TO COMPLY WITH AD-2 AND PER (11) AD-2.

KEYNOTES

- 10.043 SIGNAGE: TOILET ROOM IDENTIFICATION
- 10.051 SIGNAGE: TOILET ROOM DOOR SYMBOL
- 10.090 COMPOSITE TOILET COMPARTMENT

SHADE STRUCTURE AT JOHN BIDWELL ELEMENTARY SCHOOL
SACRAMENTO CITY UNIFIED SCHOOL DISTRICT
SACRAMENTO, CA

Revision

Copyright © 2021 Rankin-Gru Architects. All rights reserved. Reproduction of these plans, either in whole or in part, including any form of copying and/or preparation of duplicate work sheets, for any reason without prior written permission, is strictly prohibited.

TOILET ROOM DEMOLITION AND IMPROVEMENT PLANS AND INTERIOR ELEVATIONS

UNITS C1 AND D1
 PROJECT NO: 21-1894-02
 DATE: 3/1/22
 SHEET: **A2.1.1**

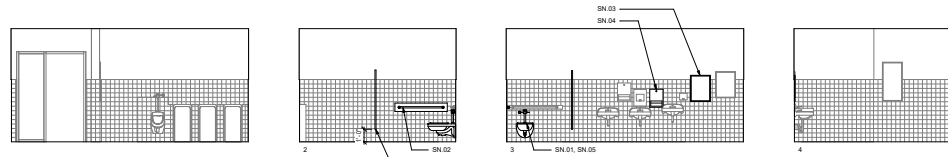

D101 - BOYS
1/4" = 1'-0"

ADULT HEIGHT

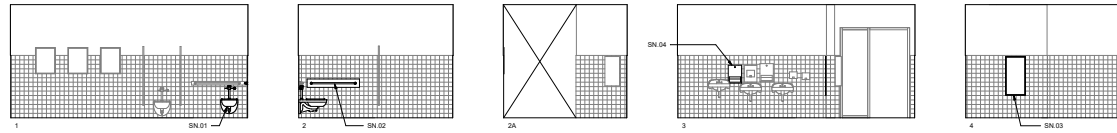

D102 - GIRLS
1/4" = 1'-0"

ADULT HEIGHT

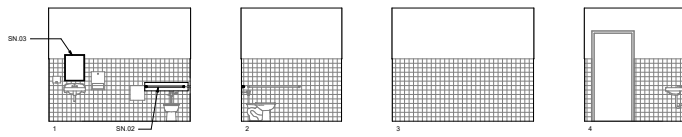

D103 - STAFF
1/4" = 1'-0"

ADULT HEIGHT

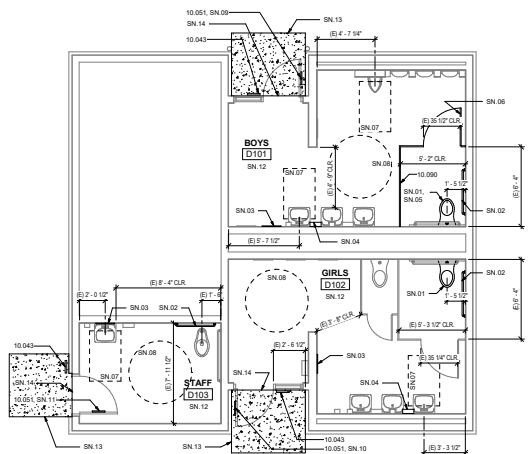

2 TOILET ROOMS - IMPROVEMENT
1/4" = 1'-0"

ADULT HEIGHT

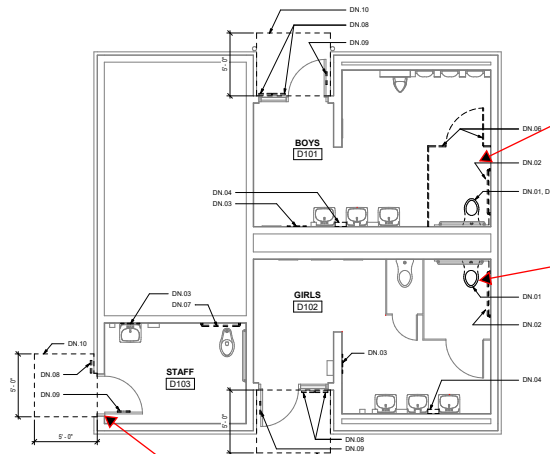

1 TOILET ROOMS - DEMOLITION
1/4" = 1'-0"

1C(-)

LEGEND



GENERAL NOTES

- FOR MOUNTING HEIGHTS, LOCATIONS, AND DETAILS, INCLUDING THOSE FOR DISABLED ACCESSIBILITY, REFER TO SHEET A&2.
- PROTECT ALL ADJACENT SURFACES, ITEMS AND FINISHES NOT NOTED TO BE DEMOLISHED.
- EQUIPMENT/FIXTURES NOTED AS "SALVAGED FOR REINSTALLATION" WILL BE REMOVED AND STORED BY THE CONTRACTOR PRIOR TO START OF DEMOLITION. THESE EQUIPMENT/FIXTURES SHALL BE REINSTALLED BY THE CONTRACTOR UNDER THIS CONTRACT.
- REMOVE ALL ITEMS SCHEDULED TO BE REMOVED, INCLUDING MOUNTING HARDWARE.
- DEMO AND REPAIR WALL FINISH AS NECESSARY TO PERFORM FIXTURE AND EQUIPMENT WORK AS NOTED. ADJACENT FINISHES TO BE VERIFIED BY CONTRACTOR.

DEMOLITION NOTES

- DN 01 REMOVE (E) WALL MOUNTED WATER CLOSET AND SALVAGE FOR REINSTALLATION
- DN 02 REMOVE (E) EISE WALL GRAB BAR AND SALVAGE FOR REINSTALLATION REMOVE (E) DN CLEAT
- DN 03 REMOVE (E) MIRROR AND SALVAGE FOR REINSTALLATION
- DN 04 REMOVE (E) PAPER TOWEL DISPENSER AND SALVAGE FOR REINSTALLATION
- DN 05 REMOVE (E) FLUSH VALVE AT (E) TOILET
- DN 06 REMOVE (E) TOILET PARTITION, SALVAGE (E) TOILET PARTITION DOOR FOR REINSTALLATION
- DN 07 REMOVE (E) BACK WALL GRAB BAR AND SALVAGE FOR REINSTALLATION
- DN 08 REMOVE (E) TOILET ROOM I.D. SIGN
- DN 09 REMOVE (E) TOILET ROOM DOOR SYMBOL
- DN 10 REMOVE (E) SECTION OF CONCRETE SLAB

SHEET NOTES

- SN 01 REINSTALL (E) SALVAGED WALL MOUNTED WATER CLOSET TO COMPLY WITH A&2. ADJUST (E) WATER CLOSET AS REQUIRED FOR RECONNECTION TO WATER CLOSET
- SN 02 REINSTALL (E) SALVAGED GRAB BAR TO COMPLY WITH A&2
- SN 03 REINSTALL (E) SALVAGED MIRROR TO COMPLY WITH A&2
- SN 04 REINSTALL (E) SALVAGED PAPER TOWEL DISPENSER TO COMPLY WITH A&2
- SN 05 PROVIDE NEW FLUSH VALVE AT SALVAGED WALL MOUNTED WATER CLOSET TO COMPLY WITH A&2
- SN 06 REINSTALL (E) SALVAGED TOILET PARTITION DOOR
- SN 07 30" X 48" CLEAR SPACE
- SN 08 80° DIA. TURNING CIRCLE
- SN 09 SIGN TO READ "BOYS"
- SN 10 SIGN TO READ "GIRLS"
- SN 11 SIGN TO READ "STAFF"
- SN 12 WRAP ALL EXPOSED PIPES WITH INSULATION
- SN 13 INSTALL NEW CONCRETE WITH 2% MAX. SLOPE IN ALL DIRECTIONS. EDGES TO HAVE A FLUSH TRANSITION TO (E) SLAB. SEE 10 A&2.
- SN 14 INSTALL DOOR THRESHOLD PER 10 A&2.

KEYNOTES

- 10.043 SIGNAGE: TOILET ROOM IDENTIFICATION
- 10.051 SIGNAGE: TOILET ROOM DOOR SYMBOL
- 10.090 COMPOSITE TOILET COMPARTMENT

1B(-)

1A(-)

SHADE STRUCTURE AT JOHN D. SLOAT ELEMENTARY SCHOOL



Revision

TOILET ROOM DEMOLITION AND IMPROVEMENT PLANS AND INTERIOR ELEVATIONS

UNIT D1
PROJECT NO. 21-1594-06

DATE: 3/1/22

SHEET A2.1.1

SACRAMENTO CITY UNIFIED SCHOOL DISTRICT
SACRAMENTO, CA

Asbestos Survey Form

(See Instructions)

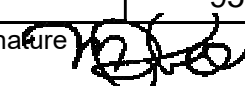
1. Purpose of Survey		x	Renovation		Demolition	
2. Facility Information						
Project Area(s) Description Alice Birney K-8 - Restrooms						
Address 6251 13th Street				City Sacramento		# of Structures
3. Owner Information						
Name						
Address			City/State			Zip
Contact	Phone	Fax	Email			
4. Consultant Information		Survey Date(s): 05/06/22				
Company Name National Analytical Laboratoires, Inc.						
Name Michael J. Lee					DOSH # 06-4047	
Address 2201 Francisco Dr. Ste. 140-261			City/State El Dorado Hills, CA			Zip 95762
Phone 916-361-0555	Fax 916-361-0540	Email Paula@nal1.com			Signature 	
5. Client Information (if different than owner)		<input type="checkbox"/> General Contractor		<input type="checkbox"/> Insurance Company		
<input type="checkbox"/> Architect		<input type="checkbox"/> Property Manager		<input type="checkbox"/> Other		
Name						
Address				City/State		Zip
Contact	Phone	Fax	Email			
6. Have all of the suspect materials that will be disturbed been sampled?						<input checked="" type="checkbox"/> Yes <input type="checkbox"/> No
If no, explain why:						
7. Summary of Total Asbestos Containing Material (ACM) Findings						
Regulated Asbestos Containing Material (RACM) (Includes materials subject to known mechanical removal and fire damaged materials)			Category II		Category I	
Square Ft.	Linear Ft.	Cubic Ft.	Square Ft.	Linear Ft.	Square Ft.	Linear Ft.
-	-	-	-	-	-	-
To receive future SMAQMD Rule updates and changes affecting your industry (check one box):						
<input type="checkbox"/> Please send e-mail notices to			<input type="checkbox"/> I will sign up myself at www.airquality.org/listserve/ to receive e-mailed notices.			
<input type="checkbox"/> I am already subscribed.		<input type="checkbox"/> I want the District to mail notices to the address on this application:			<input type="checkbox"/> Owner	<input type="checkbox"/> Consultant

SMAQMD Survey Form Instructions

- #1. Check the appropriate box as to whether the survey is for a Renovation or Demolition as defined by SMAQMD Rule 902, at the time the survey was conducted. Demolitions require sampling of all suspect materials unless assumed to contain asbestos or only a small area is being impacted by the demolition, ie, the entire building will not be razed. An example of this would be where only a load bearing wall(s) is removed but the building will remain intact. In those cases, explain why all suspect materials in the structure were not sampled in item #6. Renovations (TI's, soft demo's, remodels) require sampling of only the suspect materials that are going to be disturbed.
- #2. Provide the description and function of the building(s) or area(s), ie, "School-Boiler Room", within the building(s) being surveyed. Include the total number of floors surveyed. Provide the address of building(s) surveyed. If multiple buildings are on site, provide the total number of structures surveyed, include portables, outbuildings, garages, sheds, etc.
- #3. Provide owner information.
- #4. Provide consultant information and the date on which each building/area was surveyed in item #2.
- #5. The client refers to whoever requested the survey to be conducted and provided demolition/renovation information to the consultant. If the client is the owner in #3, leave this section blank.
- #6. Unless assumed to contain asbestos, **all** suspect materials must be sampled prior to a demolition. Prior to a renovation, unless assumed to contain asbestos, suspect materials >160 square feet, 260 linear feet, or 35 cubic feet that will be abated, stripped, or removed must be sampled. You cannot assume suspect materials are negative. Samples taken must be based on the Asbestos Hazard Emergency Response Act (AHERA) guidelines for homogeneous areas but must include both the interior and exterior suspect materials, floor to roof. The list below provides common suspect materials. Surfacing materials requiring 3,5,7 protocol are noted (3,5,7). The SMAQMD considers stucco a surfacing material. All other sampling may be done "sufficient to determine".

EPA Category of Common Suspect Asbestos Containing Materials

Note: This list does not include every product that may contain asbestos. It is intended as a general guide to show the proper NESHAP categories of materials typically containing asbestos.

Regulated Asbestos Containing Material

- Fireproofing (3,5,7)
- Acoustical Ceiling Texture (3,5,7)
- Plaster (3,5,7)
- Wall Texture (3,5,7)
- Ceiling Tiles
- HVAC Duct Insulation
- Thermal System Insulation
- Mudded Pipe Elbow Insulation
- Linoleum Backing
- Furnace Insulation
- Fire Doors
- Nicolite Roofing paper

Category II

- Stucco (3,5,7)
- Window Glazing
- Cement Board/Transite
- Mastics
- Textured Paints/Coatings
- Chalkboards
- Lab Hoods/Table Tops
- Cement Pipes
- Cement Roofing Shingles
- Caulking

Category I

- Asphalt Flooring
 - Roofing Shingles
 - Built-up Roofing
 - Base Flashing
 - Rolled Roofing
 - Boiler/Tank Insulation
 - Vinyl Floor Tile

#7. This is an estimate total of all RACM, Category I & Category II materials found in all structures listed in item #2. If Category I & II materials were subjected to fire or will be subjected to mechanical forces during removal, they must be designated as RACM. An asbestos containing material must only be designated to one category. Category I or II material cannot be listed as RACM.

Attachments (Include with Survey)

I. Findings & Recommendations

Explain the significance of the data in item #7. State that Category I material may be left in place during demolition and that RACM and Cementitious Category II material must be removed prior to the renovation or demolition. Explain that the amounts listed are to be used by the owner to obtain accurate bids from abatement contractors. State whether this is a jurisdictional project under the requirements of the federal NESHAP and SMAQMD Rule 902. For unimpacted areas in a renovation, state that untested suspect materials must be tested prior to additional future projects where the materials will be disturbed.

II. Floor Plan Map(s)

Create a separate Floor Plan Map (see example below) for each floor or area of every structure surveyed in item #2. If the roof or exterior is impacted by the project, create a separate map for the roof and exterior or include them on one of the floor maps as seen below. Name each room sampled by the commonly used name and state whether the area is undergoing Renovation or Demolition. A demolition is the wrecking, taking out or burning of any load supporting structural member. A renovation is everything else. If the survey is conducted after the demo/reno has occurred, inspect all dumpsters outside of building. Record the location of each sample taken and identify each sample with a unique identifier that will be the same as reported to the laboratory and in the following appendices. **Use “+” to describe >1% or “-” to describe = to or <1% asbestos.**

Example: Building 1 - Floor Plan Map

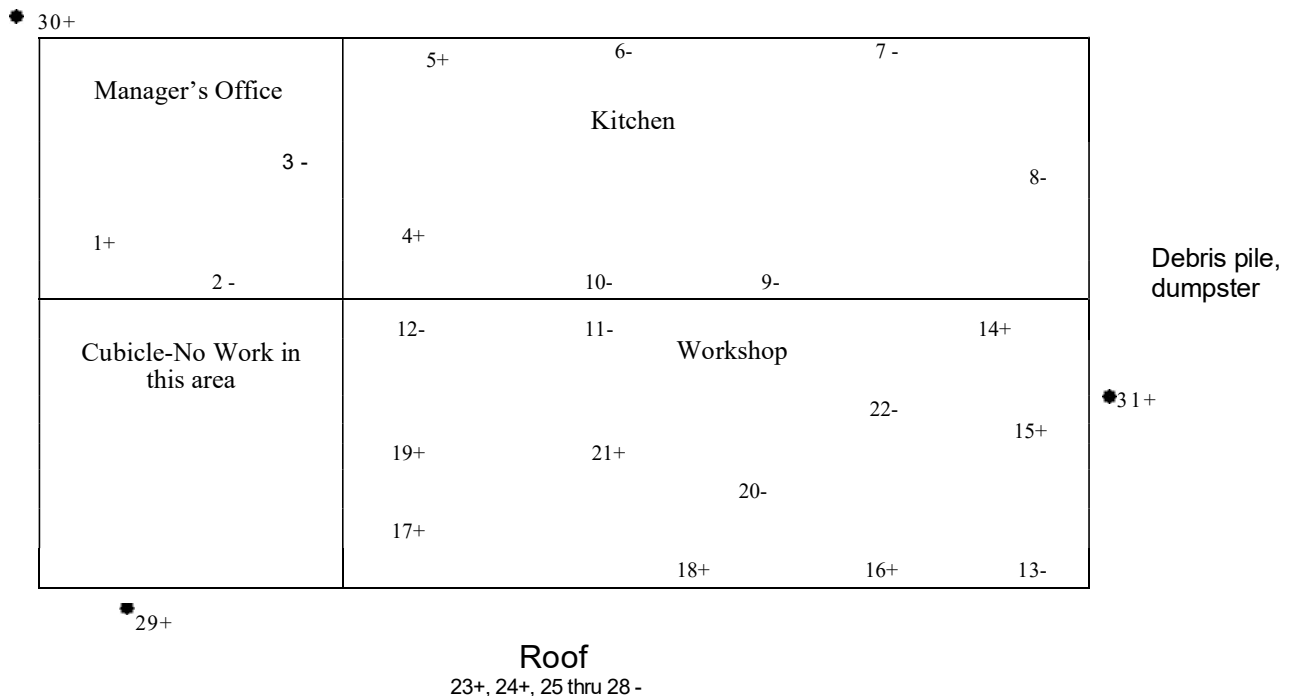

III. Sample Results

Create a table (see example below of minimal information needed to comply with SMAQMD Rule 902) for all samples >1% from all structures surveyed in item #2. Category I or Category II materials subject to known mechanical removal or fire damage must be considered RACM. Add more rows and columns as needed.

Example: Building 1 - Sample Results

Sample(s) ID#	Suspect Material	Asbestos Content (%) (PLM/PC)	EPA Category	Total Quantity Sq./Ln/Cu. Ft.
1	Ceiling tile	2.6-PC	RACM	250 sqft
4	Linoleum	40-PLM	RACM	800 sqft
5	Floor mastic	1.4-PC	RACM (mechanical removal)	250 sqft
14,16, 18	TSI	80-PLM	RACM	1,200 li.ft.
15,17, 19	Wall texture	3-PC	RACM	2,500 sqft
21	Floor tile	8-PLM	CAT II	2,500 sqft
20	Transite panels	45-PLM	CAT II	1,100 sqft
23	Nicolite felt	Assumed	RACM	12,000 sqft
24	Roof mastic	2-PLM	CAT I	12,000 sqft
29, 30, 31	Stucco	1.7 PC	RACM	5,400 sqft

IV. Lab Results

Point count (PC) all samples <10% unless assumed > 1%

V. Current proof of certification of person listed in item #4

Special Note: The following are common causes for survey rejection and potential citation by SMAQMD:

- (1)-Survey form or Appendices incomplete, incorrect or missing attachments.
- (2)-All suspect materials are not sampled or assumed to be asbestos containing in the survey (for any reason).
- (3)-Affected suspect materials are not sampled utilizing the 3,5,7 protocol.
- (4)-Point counts were not conducted, sheetrock was not composite sampled, non-sheetrock materials were composite sampled.

(5)-“**Limited Surveys** or Inaccessible Areas”- The SMAQMD is aware that renovations impact specific areas within a structure and therefore will not require sampling throughout the entire structure as a demolition survey would require. Stating that a **survey is “limited”** because all areas of the project will not be impacted or areas are inaccessible will result in rejection of the survey unless good cause is provided. There is no requirement to sample inaccessible materials, ie, materials behind a wall or encased in concrete; however, state in the “**Findings & Recommendations**” that upon discovery of previously untested, inaccessible suspect materials, work must cease until further sampling is conducted. Locked rooms or spaces above drop ceiling tiles are not considered inaccessible and are required to be sampled. The owner/operator must provide access to all impacted areas. Failure to sample suspect materials for “**cosmetic**” reasons will be rejected.

It is important to state that you cannot be prevented and/or instructed by the owner/operator as to what materials are to be sampled. This is determined by whoever conducts the survey and will give cause for survey rejection and potential citation to the owner/operator for failure to adequately survey all suspect materials.

Survey Instructions (4_13)

Asbestos Survey Form

(See Instructions)

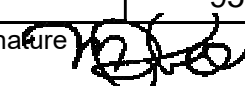
1. Purpose of Survey		x	Renovation		Demolition	
2. Facility Information						
Project Area(s) Description John Bidwell Elementary School - Restrooms						
Address 1730 65th Avenue				City Sacramento		# of Structures
3. Owner Information						
Name						
Address			City/State			Zip
Contact	Phone	Fax	Email			
4. Consultant Information		Survey Date(s): 05/06/22				
Company Name National Analytical Laboratoires, Inc.						
Name Michael J. Lee					DOSH # 06-4047	
Address 2201 Francisco Dr. Ste. 140-261			City/State El Dorado Hills, CA			Zip 95762
Phone 916-361-0555	Fax 916-361-0540	Email Paula@nal1.com			Signature 	
5. Client Information (if different than owner)		<input type="checkbox"/> General Contractor		<input type="checkbox"/> Insurance Company		
<input type="checkbox"/> Architect		<input type="checkbox"/> Property Manager		<input type="checkbox"/> Other		
Name						
Address				City/State		Zip
Contact	Phone	Fax	Email			
6. Have all of the suspect materials that will be disturbed been sampled?						<input checked="" type="checkbox"/> Yes <input type="checkbox"/> No
If no, explain why:						
7. Summary of Total Asbestos Containing Material (ACM) Findings						
Regulated Asbestos Containing Material (RACM) (Includes materials subject to known mechanical removal and fire damaged materials)			Category II		Category I	
-			-		-	
Square Ft.	Linear Ft.	Cubic Ft.	Square Ft.	Linear Ft.	Square Ft.	Linear Ft.
To receive future SMAQMD Rule updates and changes affecting your industry (check one box):						
<input type="checkbox"/> Please send e-mail notices to			<input type="checkbox"/> I will sign up myself at www.airquality.org/listserve/ to receive e-mailed notices.			
<input type="checkbox"/> I am already subscribed.		<input type="checkbox"/> I want the District to mail notices to the address on this application:			<input type="checkbox"/> Owner	<input type="checkbox"/> Consultant

SMAQMD Survey Form Instructions

- #1. Check the appropriate box as to whether the survey is for a Renovation or Demolition as defined by SMAQMD Rule 902, at the time the survey was conducted. Demolitions require sampling of all suspect materials unless assumed to contain asbestos or only a small area is being impacted by the demolition, ie, the entire building will not be razed. An example of this would be where only a load bearing wall(s) is removed but the building will remain intact. In those cases, explain why all suspect materials in the structure were not sampled in item #6. Renovations (TI's, soft demo's, remodels) require sampling of only the suspect materials that are going to be disturbed.
- #2. Provide the description and function of the building(s) or area(s), ie, "School-Boiler Room", within the building(s) being surveyed. Include the total number of floors surveyed. Provide the address of building(s) surveyed. If multiple buildings are on site, provide the total number of structures surveyed, include portables, outbuildings, garages, sheds, etc.
- #3. Provide owner information.
- #4. Provide consultant information and the date on which each building/area was surveyed in item #2.
- #5. The client refers to whoever requested the survey to be conducted and provided demolition/renovation information to the consultant. If the client is the owner in #3, leave this section blank.
- #6. Unless assumed to contain asbestos, **all** suspect materials must be sampled prior to a demolition. Prior to a renovation, unless assumed to contain asbestos, suspect materials >160 square feet, 260 linear feet, or 35 cubic feet that will be abated, stripped, or removed must be sampled. You cannot assume suspect materials are negative. Samples taken must be based on the Asbestos Hazard Emergency Response Act (AHERA) guidelines for homogeneous areas but must include both the interior and exterior suspect materials, floor to roof. The list below provides common suspect materials. Surfacing materials requiring 3,5,7 protocol are noted (3,5,7). The SMAQMD considers stucco a surfacing material. All other sampling may be done "sufficient to determine".

EPA Category of Common Suspect Asbestos Containing Materials

Note: This list does not include every product that may contain asbestos. It is intended as a general guide to show the proper NESHAP categories of materials typically containing asbestos.

Regulated Asbestos Containing Material

- Fireproofing (3,5,7)
- Acoustical Ceiling Texture (3,5,7)
- Plaster (3,5,7)
- Wall Texture (3,5,7)
- Ceiling Tiles
- HVAC Duct Insulation
- Thermal System Insulation
- Mudded Pipe Elbow Insulation
- Linoleum Backing
- Furnace Insulation
- Fire Doors
- Nicolite Roofing paper

Category II

- Stucco (3,5,7)
- Window Glazing
- Cement Board/Transite
- Mastics
- Textured Paints/Coatings
- Chalkboards
- Lab Hoods/Table Tops
- Cement Pipes
- Cement Roofing Shingles
- Caulking

Category I

- Asphalt Flooring
 - Roofing Shingles
 - Built-up Roofing
 - Base Flashing
 - Rolled Roofing
 - Boiler/Tank Insulation
 - Vinyl Floor Tile

#7. This is an estimate total of all RACM, Category I & Category II materials found in all structures listed in item #2. If Category I & II materials were subjected to fire or will be subjected to mechanical forces during removal, they must be designated as RACM. An asbestos containing material must only be designated to one category. Category I or II material cannot be listed as RACM.

Attachments (Include with Survey)

I. Findings & Recommendations

Explain the significance of the data in item #7. State that Category I material may be left in place during demolition and that RACM and Cementitious Category II material must be removed prior to the renovation or demolition. Explain that the amounts listed are to be used by the owner to obtain accurate bids from abatement contractors. State whether this is a jurisdictional project under the requirements of the federal NESHAP and SMAQMD Rule 902. For unimpacted areas in a renovation, state that untested suspect materials must be tested prior to additional future projects where the materials will be disturbed.

II. Floor Plan Map(s)

Create a separate Floor Plan Map (see example below) for each floor or area of every structure surveyed in item #2. If the roof or exterior is impacted by the project, create a separate map for the roof and exterior or include them on one of the floor maps as seen below. Name each room sampled by the commonly used name and state whether the area is undergoing Renovation or Demolition. A demolition is the wrecking, taking out or burning of any load supporting structural member. A renovation is everything else. If the survey is conducted after the demo/reno has occurred, inspect all dumpsters outside of building. Record the location of each sample taken and identify each sample with a unique identifier that will be the same as reported to the laboratory and in the following appendices. **Use “+” to describe >1% or “-” to describe = to or <1% asbestos.**

Example: Building 1 - Floor Plan Map

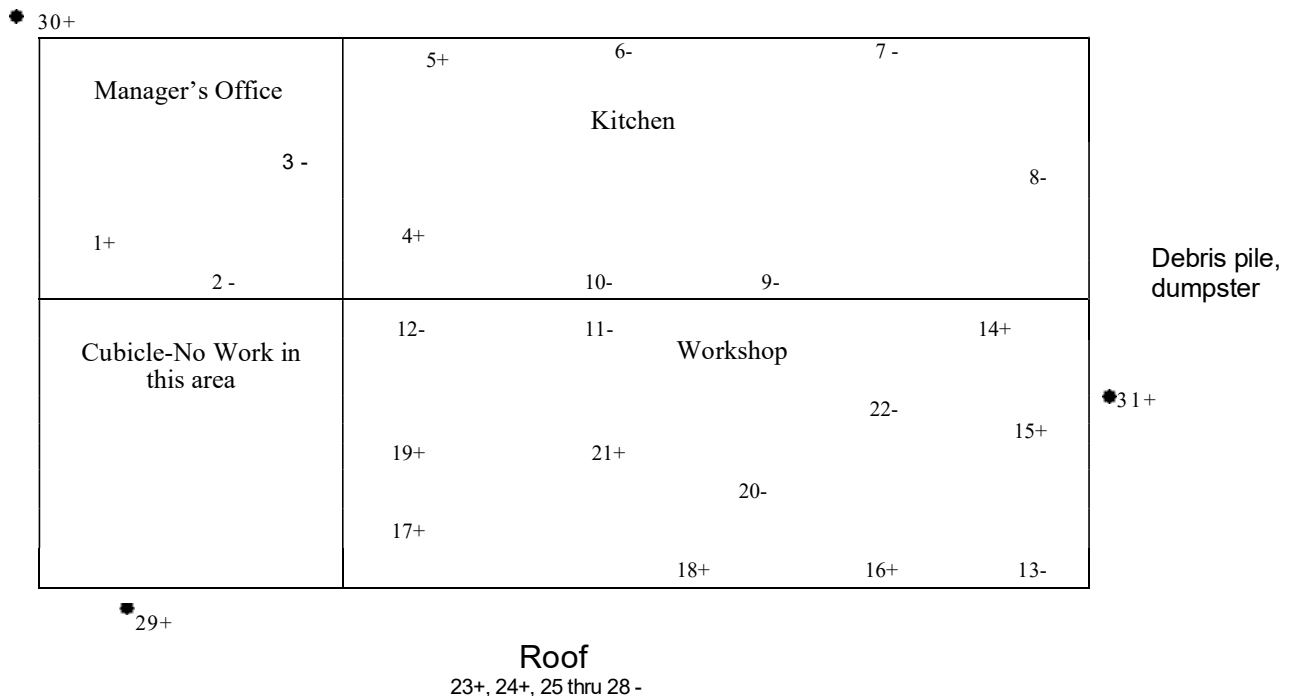

III. Sample Results

Create a table (see example below of minimal information needed to comply with SMAQMD Rule 902) for all samples >1% from all structures surveyed in item #2. Category I or Category II materials subject to known mechanical removal or fire damage must be considered RACM. Add more rows and columns as needed.

Example: Building 1 - Sample Results

Sample(s) ID#	Suspect Material	Asbestos Content (%) (PLM/PC)	EPA Category	Total Quantity Sq./Ln/Cu. Ft.
1	Ceiling tile	2.6-PC	RACM	250 sqft
4	Linoleum	40-PLM	RACM	800 sqft
5	Floor mastic	1.4-PC	RACM (mechanical removal)	250 sqft
14,16, 18	TSI	80-PLM	RACM	1,200 li.ft.
15,17, 19	Wall texture	3-PC	RACM	2,500 sqft
21	Floor tile	8-PLM	CAT II	2,500 sqft
20	Transite panels	45-PLM	CAT II	1,100 sqft
23	Nicolite felt	Assumed	RACM	12,000 sqft
24	Roof mastic	2-PLM	CAT I	12,000 sqft
29, 30, 31	Stucco	1.7 PC	RACM	5,400 sqft

IV. Lab Results

Point count (PC) all samples <10% unless assumed > 1%

V. Current proof of certification of person listed in item #4

Special Note: The following are common causes for survey rejection and potential citation by SMAQMD:

- (1)-Survey form or Appendices incomplete, incorrect or missing attachments.
- (2)-All suspect materials are not sampled or assumed to be asbestos containing in the survey (for any reason).
- (3)-Affected suspect materials are not sampled utilizing the 3,5,7 protocol.
- (4)-Point counts were not conducted, sheetrock was not composite sampled, non-sheetrock materials were composite sampled.

(5)-“**Limited Surveys** or Inaccessible Areas”- The SMAQMD is aware that renovations impact specific areas within a structure and therefore will not require sampling throughout the entire structure as a demolition survey would require. Stating that a **survey is “limited”** because all areas of the project will not be impacted or areas are inaccessible will result in rejection of the survey unless good cause is provided. There is no requirement to sample inaccessible materials, ie, materials behind a wall or encased in concrete; however, state in the “**Findings & Recommendations**” that upon discovery of previously untested, inaccessible suspect materials, work must cease until further sampling is conducted. Locked rooms or spaces above drop ceiling tiles are not considered inaccessible and are required to be sampled. The owner/operator must provide access to all impacted areas. Failure to sample suspect materials for “**cosmetic**” reasons will be rejected.

It is important to state that you cannot be prevented and/or instructed by the owner/operator as to what materials are to be sampled. This is determined by whoever conducts the survey and will give cause for survey rejection and potential citation to the owner/operator for failure to adequately survey all suspect materials.

Survey Instructions (4_13)

Asbestos Survey Form

(See Instructions)

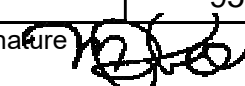
1. Purpose of Survey		x	Renovation		Demolition	
2. Facility Information						
Project Area(s) Description John Sloat Elementary School - Restrooms						
Address 7525 Candlewood Way				City Sacramento		# of Structures
3. Owner Information						
Name						
Address			City/State			Zip
Contact	Phone	Fax	Email			
4. Consultant Information		Survey Date(s): 05/06/22				
Company Name National Analytical Laboratoires, Inc.						
Name Michael J. Lee					DOSH # 06-4047	
Address 2201 Francisco Dr. Ste. 140-261			City/State El Dorado Hills, CA			Zip 95762
Phone 916-361-0555	Fax 916-361-0540	Email Paula@nal1.com			Signature 	
5. Client Information (if different than owner)		<input type="checkbox"/> General Contractor		<input type="checkbox"/> Insurance Company		
<input type="checkbox"/> Architect		<input type="checkbox"/> Property Manager		<input type="checkbox"/> Other		
Name						
Address				City/State		Zip
Contact	Phone	Fax	Email			
6. Have all of the suspect materials that will be disturbed been sampled?						<input checked="" type="checkbox"/> Yes <input type="checkbox"/> No
If no, explain why:						
7. Summary of Total Asbestos Containing Material (ACM) Findings						
Regulated Asbestos Containing Material (RACM) (Includes materials subject to known mechanical removal and fire damaged materials)			Category II		Category I	
-			-		-	
Square Ft.	Linear Ft.	Cubic Ft.	Square Ft.	Linear Ft.	Square Ft.	Linear Ft.
To receive future SMAQMD Rule updates and changes affecting your industry (check one box):						
<input type="checkbox"/> Please send e-mail notices to			<input type="checkbox"/> I will sign up myself at www.airquality.org/listserve/ to receive e-mailed notices.			
<input type="checkbox"/> I am already subscribed.		<input type="checkbox"/> I want the District to mail notices to the address on this application:			<input type="checkbox"/> Owner	<input type="checkbox"/> Consultant

SMAQMD Survey Form Instructions

- #1. Check the appropriate box as to whether the survey is for a Renovation or Demolition as defined by SMAQMD Rule 902, at the time the survey was conducted. Demolitions require sampling of all suspect materials unless assumed to contain asbestos or only a small area is being impacted by the demolition, ie, the entire building will not be razed. An example of this would be where only a load bearing wall(s) is removed but the building will remain intact. In those cases, explain why all suspect materials in the structure were not sampled in item #6. Renovations (TI's, soft demo's, remodels) require sampling of only the suspect materials that are going to be disturbed.
- #2. Provide the description and function of the building(s) or area(s), ie, "School-Boiler Room", within the building(s) being surveyed. Include the total number of floors surveyed. Provide the address of building(s) surveyed. If multiple buildings are on site, provide the total number of structures surveyed, include portables, outbuildings, garages, sheds, etc.
- #3. Provide owner information.
- #4. Provide consultant information and the date on which each building/area was surveyed in item #2.
- #5. The client refers to whoever requested the survey to be conducted and provided demolition/renovation information to the consultant. If the client is the owner in #3, leave this section blank.
- #6. Unless assumed to contain asbestos, **all** suspect materials must be sampled prior to a demolition. Prior to a renovation, unless assumed to contain asbestos, suspect materials >160 square feet, 260 linear feet, or 35 cubic feet that will be abated, stripped, or removed must be sampled. You cannot assume suspect materials are negative. Samples taken must be based on the Asbestos Hazard Emergency Response Act (AHERA) guidelines for homogeneous areas but must include both the interior and exterior suspect materials, floor to roof. The list below provides common suspect materials. Surfacing materials requiring 3,5,7 protocol are noted (3,5,7). The SMAQMD considers stucco a surfacing material. All other sampling may be done "sufficient to determine".

EPA Category of Common Suspect Asbestos Containing Materials

Note: This list does not include every product that may contain asbestos. It is intended as a general guide to show the proper NESHAP categories of materials typically containing asbestos.

Regulated Asbestos Containing Material

- Fireproofing (3,5,7)
- Acoustical Ceiling Texture (3,5,7)
- Plaster (3,5,7)
- Wall Texture (3,5,7)
- Ceiling Tiles
- HVAC Duct Insulation
- Thermal System Insulation
- Mudded Pipe Elbow Insulation
- Linoleum Backing
- Furnace Insulation
- Fire Doors
- Nicolite Roofing paper

Category II

- Stucco (3,5,7)
- Window Glazing
- Cement Board/Transite
- Mastics
- Textured Paints/Coatings
- Chalkboards
- Lab Hoods/Table Tops
- Cement Pipes
- Cement Roofing Shingles
- Caulking

Category I

- Asphalt Flooring
 - Roofing Shingles
 - Built-up Roofing
 - Base Flashing
 - Rolled Roofing
 - Boiler/Tank Insulation
 - Vinyl Floor Tile

#7. This is an estimate total of all RACM, Category I & Category II materials found in all structures listed in item #2. If Category I & II materials were subjected to fire or will be subjected to mechanical forces during removal, they must be designated as RACM. An asbestos containing material must only be designated to one category. Category I or II material cannot be listed as RACM.

Attachments (Include with Survey)

I. Findings & Recommendations

Explain the significance of the data in item #7. State that Category I material may be left in place during demolition and that RACM and Cementitious Category II material must be removed prior to the renovation or demolition. Explain that the amounts listed are to be used by the owner to obtain accurate bids from abatement contractors. State whether this is a jurisdictional project under the requirements of the federal NESHAP and SMAQMD Rule 902. For unimpacted areas in a renovation, state that untested suspect materials must be tested prior to additional future projects where the materials will be disturbed.

II. Floor Plan Map(s)

Create a separate Floor Plan Map (see example below) for each floor or area of every structure surveyed in item #2. If the roof or exterior is impacted by the project, create a separate map for the roof and exterior or include them on one of the floor maps as seen below. Name each room sampled by the commonly used name and state whether the area is undergoing Renovation or Demolition. A demolition is the wrecking, taking out or burning of any load supporting structural member. A renovation is everything else. If the survey is conducted after the demo/reno has occurred, inspect all dumpsters outside of building. Record the location of each sample taken and identify each sample with a unique identifier that will be the same as reported to the laboratory and in the following appendices. **Use “+” to describe >1% or “-” to describe = to or <1% asbestos.**

Example: Building 1 - Floor Plan Map

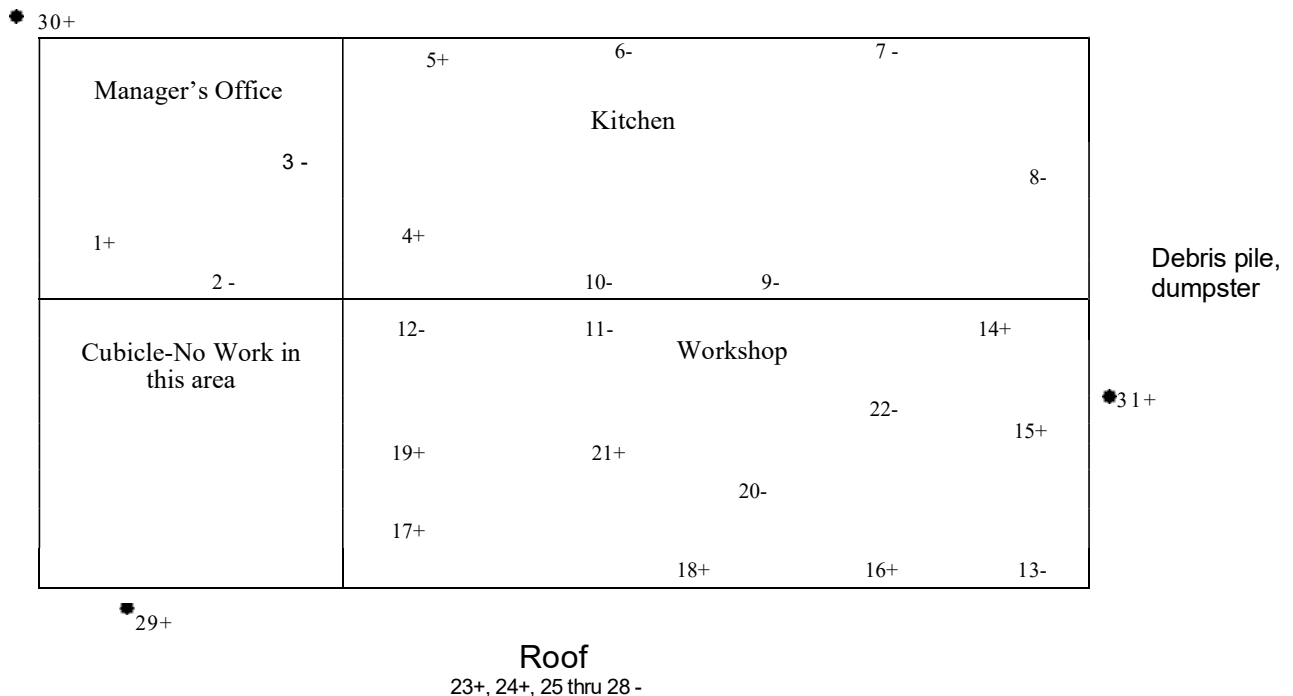

III. Sample Results

Create a table (see example below of minimal information needed to comply with SMAQMD Rule 902) for all samples >1% from all structures surveyed in item #2. Category I or Category II materials subject to known mechanical removal or fire damage must be considered RACM. Add more rows and columns as needed.

Example: Building 1 - Sample Results

Sample(s) ID#	Suspect Material	Asbestos Content (%) (PLM/PC)	EPA Category	Total Quantity Sq./Ln/Cu. Ft.
1	Ceiling tile	2.6-PC	RACM	250 sqft
4	Linoleum	40-PLM	RACM	800 sqft
5	Floor mastic	1.4-PC	RACM (mechanical removal)	250 sqft
14,16, 18	TSI	80-PLM	RACM	1,200 li.ft.
15,17, 19	Wall texture	3-PC	RACM	2,500 sqft
21	Floor tile	8-PLM	CAT II	2,500 sqft
20	Transite panels	45-PLM	CAT II	1,100 sqft
23	Nicolite felt	Assumed	RACM	12,000 sqft
24	Roof mastic	2-PLM	CAT I	12,000 sqft
29, 30, 31	Stucco	1.7 PC	RACM	5,400 sqft

IV. Lab Results

Point count (PC) all samples <10% unless assumed > 1%

V. Current proof of certification of person listed in item #4

Special Note: The following are common causes for survey rejection and potential citation by SMAQMD:

- (1)-Survey form or Appendices incomplete, incorrect or missing attachments.
- (2)-All suspect materials are not sampled or assumed to be asbestos containing in the survey (for any reason).
- (3)-Affected suspect materials are not sampled utilizing the 3,5,7 protocol.
- (4)-Point counts were not conducted, sheetrock was not composite sampled, non-sheetrock materials were composite sampled.

(5)-“**Limited Surveys** or Inaccessible Areas”- The SMAQMD is aware that renovations impact specific areas within a structure and therefore will not require sampling throughout the entire structure as a demolition survey would require. Stating that a **survey is “limited”** because all areas of the project will not be impacted or areas are inaccessible will result in rejection of the survey unless good cause is provided. There is no requirement to sample inaccessible materials, ie, materials behind a wall or encased in concrete; however, state in the “**Findings & Recommendations**” that upon discovery of previously untested, inaccessible suspect materials, work must cease until further sampling is conducted. Locked rooms or spaces above drop ceiling tiles are not considered inaccessible and are required to be sampled. The owner/operator must provide access to all impacted areas. Failure to sample suspect materials for “**cosmetic**” reasons will be rejected.

It is important to state that you cannot be prevented and/or instructed by the owner/operator as to what materials are to be sampled. This is determined by whoever conducts the survey and will give cause for survey rejection and potential citation to the owner/operator for failure to adequately survey all suspect materials.

Survey Instructions (4_13)

TABLE OF CONTENTS

Procurement and Contracting Requirements

<u>Division 0</u>	<u>Section</u>	<u>Title</u>
	00 01 01	Project Title Page
	00 01 03	Seals Pages
	00 01 10	Table of Contents
	00 01 15	List of Drawings and Tables

Solicitation

<u>Division 0</u>	<u>Section</u>	<u>Title</u>
	00 11 16	Notice to Bidders

Instructions for Procurement

<u>Division 0</u>	<u>Section</u>	<u>Title</u>
	00 21 13	Instructions to Bidders

Available Information

<u>Division 0</u>	<u>Section</u>	<u>Title</u>
	00 31 19	Existing Conditions
	00 31 32	Geotechnical Data

Procurement Forms and Supplements

<u>Division 0</u>	<u>Section</u>	<u>Title</u>
	00 41 13	Bid Form and Proposal
	00 43 13	Bid Bond
	00 43 36	Designated Subcontractors List
	00 45 01	Site Visit Certification
	00 45 19	Non-Collusion Declaration
	00 45 19.01	Iran Contracting Act Certification
	00 45 26	Workers' Compensation Certification
	00 45 46.01	Prevailing Wage and Related Labor Requirements Certification
	00 45 46.02	Disabled Veteran Business Enterprise Participation Certification
	00 45 46.03	Drug-Free Workplace Certification
	00 45 46.04	Tobacco-Free Environment Certification
	00 45 46.05	Hazardous Materials Certification
	00 45 46.06	Lead-Based Materials Certification
	00 45 46.07	Imported Materials Certification
	00 45 46.08	Criminal Background Investigation/Fingerprinting Certification

TABLE OF CONTENTS

00 45 46.09	Buy American Certification
00 45 46.10	Roofing Project Certification
00 45 46.11	Federal Debarment Certification
00 45 46.12	Federal Byrd Anti-Lobbying Certification
00 45 49	Registered Subcontractors List
00 45 90	Post Bid Interview

Contracting Forms and Supplements

<u>Division 0</u>	<u>Section</u>	<u>Title</u>
	00 52 13	Agreement Form – Stipulated Sum (Single-Prime Contract)
	00 56 00	Escrow Bid Documentation
	00 57 00	Escrow Agreement in Lieu of Retention

Project Forms

<u>Division 0</u>	<u>Section</u>	<u>Title</u>
	00 61 13.13	Performance Bond
	00 61 13.16	Payment Bond
	00 63 40	Allowance Expenditure Directive Form
	00 63 47	Daily Force Account Report
	00 63 57	Proposed Change Order Form
	00 63 63	Change Order Form
	00 65 19.26	Agreement and Release of Any and All Claims
	00 65 36	Guarantee Form

Conditions of the Contract

<u>Division 0</u>	<u>Section</u>	<u>Title</u>
	00 72 13	General Conditions – Stipulated Sum (Single-Prime Contract)
	00 73 13	Special Conditions
	00 73 56	Hazardous Materials Procedures and Requirements

General Requirements

<u>Division 1</u>	<u>Section</u>	<u>Title</u>
	01 11 00	Summary of Work

Price and Payment Procedures

<u>Division 1</u>	<u>Section</u>	<u>Title</u>
	01 21 00	Allowance
	01 22 00	Alternatives and Unit Prices

TABLE OF CONTENTS

01 25 13	Product Options and Substitutions
01 26 00	Changes in the Work
01 29 00	Application for Payment and Conditional and Unconditional Waiver and Release Forms

Administrative Requirements

<u>Division 1</u>	<u>Section</u>	<u>Title</u>
	01 31 19	Project Meetings
	01 32 13	Scheduling of Work
	01 33 00	Submittals
	01 35 13.23	Site Standards

Quality Requirements

<u>Division 1</u>	<u>Section</u>	<u>Title</u>
	01 41 00	Regulatory Requirements
	01 42 13	Abbreviations and Acronyms
	01 42 16	Definitions
	01 42 19	References
	01 43 00	Materials and Equipment
	01 45 00	Quality Control

Temporary Facilities and Controls

<u>Division 1</u>	<u>Section</u>	<u>Title</u>
	01 50 00	Temporary Facilities and Controls
	01 50 13	Construction Waste Management and Disposal
	01 52 13	Field Offices

Product Requirements

<u>Division 1</u>	<u>Section</u>	<u>Title</u>
	01 64 00	Owner-Furnished Products
	01 66 00	Product Delivery, Storage and Handling

Execution and Closeout Requirements

<u>Division 1</u>	<u>Section</u>	<u>Title</u>
	01 71 23	Field Engineering
	01 73 29	Cutting and Patching
	01 76 00	Alteration Project Procedures
	01 77 00	Contract Closeout and Final Cleaning
	01 78 23	Operation and Maintenance Data
	01 78 36	Warranties
	01 78 39	Record Documents

TABLE OF CONTENTS

Technical Specifications

DIVISION 02 - EXISTING CONDITIONS - NOT USED

DIVISION 03 - CONCRETE - NOT USED

DIVISION 04 - MASONRY - NOT USED

DIVISION 05 - METALS

SECTION 05 5000 - Metal Fabrications

DIVISION 06 - WOOD, PLASTICS, AND COMPOSITES - NOT USED

DIVISION 07 - THERMAL AND MOISTURE PROTECTION

SECTION 07 9200 – Joint Sealants

DIVISION 08 - OPENINGS - NOT USED

DIVISION 09 - FINISHES

SECTION 09 9100 – Painting

DIVISION 10 - SPECIALTIES

SECTION 10 1400 - Signage
 10 2113 - Plastic Toilet Compartments
 10 2813 - Toilet Accessories

DIVISION 11 - EQUIPMENT - NOT USED

DIVISION 12 - FURNISHINGS - NOT USED

DIVISION 13 - SPECIAL CONSTRUCTION - NOT USED

DIVISION 14 - CONVEYING EQUIPMENT - NOT USED

DIVISION 21 - FIRE SUPPRESSION - NOT USED

DIVISION 22 - PLUMBING - NOT USED

DIVISION 23 - HEATING, VENTILATING AND AIR CONDITIONING (HVAC) - NOT USED

DIVISION 26 - ELECTRICAL

SECTION 26 0150 - Electrical Basic Materials and Methods

DIVISION 27 - COMMUNICATIONS - NOT USED

DIVISION 28 - ELECTRONIC SAFETY AND SECURITY - NOT USED

DIVISION 31 - EARTHWORK

TABLE OF CONTENTS

SECTION 31 0000 - Earthwork
 31 2333 - Trenching and Backfilling

DIVISION 32 - EXTERIOR IMPROVEMENTS

SECTION 32 1200 - Asphalt Concrete Paving
 32 1600 - Site Concrete
 32 3119 - Decorative Metal Fences and Gates (All-Welded)

DIVISION 33 - UTILITIES - NOT USED

SECTION 33 4000 - Storm Drainage Utilities

"All rights reserved. This Project Manual or any part hereof may not be duplicated without the written consent of Rainforth Grau Architects except in the form of excerpts or quotations for the purpose of review."

AGREEMENT

THIS AGREEMENT IS MADE AND ENTERED INTO THIS _____ DAY OF _____
_____, 20____, by and between the Sacramento City Unified School District ("District") and _____
_____. ("Contractor")
("Agreement").

WITNESSETH: That the parties hereto have mutually covenanted and agreed, and by these presents do covenant and agree with each other, as follows:

1. **The Work:** Contractor agrees to furnish all tools, equipment, apparatus, facilities, labor, and material necessary to perform and complete in a good and workmanlike manner, the work of the following project:

Shade Structures Group 1B

("Project" or "Contract" or "Work")

It is understood and agreed that the Work shall be performed and completed as required in the Contract Documents including, without limitation, the Drawings and Specifications and submission of all documents required to secure funding or by the Division of the State Architect for close-out of the Project, under the direction and supervision of, and subject to the approval of, the District or its authorized representative.

2. **The Contract Documents:** The complete Contract consists of all Contract Documents as defined in the General Conditions and incorporated herein by this reference. Any and all obligations of the District and Contractor are fully set forth and described in the Contract Documents. All Contract Documents are intended to cooperate so that any Work called for in one and not mentioned in the other or vice versa is to be executed the same as if mentioned in all Contract Documents.
3. **Interpretation of Contract Documents:** Should any question arise concerning the intent or meaning of Contract Documents, including the Drawings or Specifications, the question shall be submitted to the District for interpretation. If a conflict exists in the Contract Documents, valid, written modifications, beginning with the most recent, shall control over this Agreement (if any), which shall control over the Special Conditions, which shall control over any Supplemental Conditions, which shall control over the General Conditions, which shall control over the remaining Division 0 documents, which shall control over Division 1 Documents which shall control over Division 2 through Division 49 documents, which shall control over figured dimensions, which shall control over large-scale drawings, which shall control over small-scale drawings. In the case of a discrepancy or ambiguity solely between and among the Drawings and Specifications, the discrepancy or ambiguity shall be resolved in favor of the interpretation that will provide District with the functionally complete and operable Project described in the Drawings and Specifications. In no case shall a document calling for lower quality and/or quantity material or workmanship control. The decision of the District in the matter shall be final.

4. **Time for Completion:** It is hereby understood and agreed that the Work under this Contract shall be completed by December 31, 2022.
5. **Completion - Extension of Time:** Should the Contractor fail to complete this Contract, and the Work provided herein, within the time fixed for completion, due allowance being made for the contingencies provided for herein, the Contractor shall become liable to the District for all loss and damage that the District may suffer on account thereof. The Contractor shall coordinate its Work with the Work of all other contractors. The District shall not be liable for delays resulting from Contractor's failure to coordinate its Work with other contractors in a manner that will allow timely completion of Contractor's Work. Contractor shall be liable for delays to other contractors caused by Contractor's failure to coordinate its Work with the Work of other contractors.
6. **Liquidated Damages:** Time is of the essence for all work under this Agreement. It is hereby understood and agreed that it is and will be difficult and/or impossible to ascertain and determine the actual damage that the District will sustain in the event of and by reason of Contractor's delay; therefore, Contractor agrees that it shall pay to the District the sum of five-hundred dollars (\$500.00) per day as liquidated damages for each and every day's delay beyond the time herein prescribed in completion of the Work.

It is hereby understood and agreed that this amount is not a penalty.

In the event that any portion of the liquidated damages is not paid to the District, the District may deduct that amount from any money due or that may become due the Contractor under this Agreement, and such deduction does not constitute a withholding or penalty. The District's right to assess liquidated damages is as indicated herein and in the General Conditions.

The time during which the Contract is delayed for cause, as hereinafter specified, may extend the time of completion for a reasonable time as the District may grant, provided that Contractor has complied with the claims procedure of the Contract Documents. This provision does not exclude the recovery of damages by either party under other provisions in the Contract Documents.

7. **Loss Or Damage:** The District and its agents and authorized representatives shall not in any way or manner be answerable or suffer loss, damage, expense, or liability for any loss or damage that may happen to the Work, or any part thereof, or in or about the same during its construction and before acceptance, and the Contractor shall assume all liabilities of every kind or nature arising from the Work, either by accident, negligence, theft, vandalism, or any cause whatsoever; and shall hold the District and its agents and authorized representatives harmless from all liability of every kind and nature arising from accident, negligence, or any cause whatsoever.
8. **Limitation Of District Liability:** District's financial obligations under this Contract shall be limited to the payment of the compensation provided in this Contract. Notwithstanding any other provision of this Contract, in no event shall District be liable, regardless of whether any claim is based on contract or tort, for any special, consequential, indirect or incidental damages, including, but not limited to, lost profits or revenue, lost bonding capacity, arising out of or in connection with this Contract for the services performed in connection with this Contract.

9. **Insurance and Bonds:** Prior to issuance of the Notice to Proceed by the District, Contractor shall provide all required certificates of insurance, insurance endorsements, and payment and performance bonds as evidence thereof.
10. **Prosecution of Work:** If the Contractor should neglect to prosecute the Work properly or fail to perform any provisions of this Contract, the District, may, pursuant to the General Conditions and without prejudice to any other remedy it may have, make good such deficiencies and may deduct the cost thereof from the payment then or thereafter due the Contractor.
11. **Authority of Architect, Project Inspector, and DSA:** Contractor hereby acknowledges that the Architect(s), the Project Inspector(s), and the Division of the State Architect ("DSA") have authority to approve and/or suspend Work if the Contractor's Work does not comply with the requirements of the Contract Documents, Title 24 of the California Code of Regulations, and all applicable laws and regulations. The Contractor shall be liable for any delay caused by its non-compliant Work.
12. **Assignment of Contract:** Neither the Contract, nor any part thereof, nor any moneys due or to become due thereunder, may be assigned by the Contractor without the prior written approval of the District, nor without the written consent of the Surety on the Contractor's Performance Bond (the "Surety"), unless the Surety has waived in writing its right to notice of assignment.
13. **Classification of Contractor's License:** Contractor hereby acknowledges that it currently holds valid Class A or B Contractor's license(s) issued by the State of California, Contractors' State License Board, in accordance with division 3, chapter 9, of the Business and Professions Code and in the classification called for in the Contract Documents.
14. **Registration as Public Works Contractor:** The Contractor and all Subcontractors currently are registered as public works contractors with the Department of Industrial Relations, State of California, in accordance with Labor Code section 1771.1.
15. **Payment of Prevailing Wages:** The Contractor and all Subcontractors shall pay all workers on all Work performed pursuant to this Contract not less than the general prevailing rate of per diem wages and the general prevailing rate for holiday and overtime work as determined by the Director of the Department of Industrial Relations, State of California, for the type of work performed and the locality in which the work is to be performed within the boundaries of the District, pursuant to sections 1770 et seq. of the California Labor Code. The Contractor and all Subcontractors shall comply with the Davis Bacon Act, applicable reporting requirements, and any other applicable requirements for federal funding. If a conflict exists, the more stringent provision shall control over this Agreement.
16. **Labor Compliance Monitoring and Enforcement:** This Project is subject to labor compliance monitoring and enforcement by the Department of Industrial Relations pursuant to Labor Code section 1771.4 and Title 8 of the California Code of Regulations. Contractor specifically acknowledges and understands that it shall perform the Work of this Agreement while complying with all the applicable provisions of Division 2, Part 7, Chapter 1, of the Labor Code, including, without limitation, the requirement that the Contractor and all of its Subcontractors shall

timely submit complete and accurate electronic certified payroll records as required by the Contract Documents, or the District may not issue payment.

17. **Contract Price:** In consideration of the foregoing covenants, promises, and agreements on the part of the Contractor, and the strict and literal fulfillment of each and every covenant, promise, and agreement, and as compensation agreed upon for the Work and construction, erection, and completion as aforesaid, the District covenants, promises, and agrees that it will well and truly pay and cause to be paid to the Contractor in full, and as the full Contract Price and compensation for construction, erection, and completion of the Work hereinabove agreed to be performed by the Contractor, the following price:

_____ Dollars
(\$ _____),

in lawful money of the United States, which sum is to be paid according to the schedule provided by the Contractor and accepted by the District and subject to additions and deductions as provided in the Contract. This amount supersedes any previously stated and/or agreed to amount(s).

18. **No Representations:** No representations have been made other than as set forth in writing in the Contract Documents, including this Agreement. Each of the Parties to this Agreement warrants that it has carefully read and understood the terms and conditions of this Agreement and all Contract Documents, and that it has not relied upon the representations or advice of any other Party or any attorney not its own.
19. **Entire Agreement:** The Contract Documents, including this Agreement, set forth the entire agreement between the parties hereto and fully supersede any and all prior agreements, understandings, written or oral, between the parties hereto pertaining to the subject matter thereof.
20. **Severability:** If any term, covenant, condition, or provision in any of the Contract Documents is held by a court of competent jurisdiction to be invalid, void or unenforceable, the remainder of the provisions in the Contract Documents shall remain in full force and effect and shall in no way be affected, impaired, or invalidated thereby.
21. **Authority of Signatories:** Each party has the full power and authority to enter into and perform this Contract, and the person signing this Contract on behalf of each party has been properly authorized and empowered to enter into this Contract. This Contract may be executed in one or more counterparts, each of which shall be deemed an original. For this Agreement, and for all Contract Documents requiring a signature, a facsimile or electronic signature shall be deemed to be the equivalent of the actual original signature. All counterparts so executed shall constitute one Contract binding all the Parties hereto.

[SIGNATURES ON FOLLOWING PAGE]

IN WITNESS WHEREOF, accepted and agreed on the date indicated above:

[CONTRACTOR NAME]

**SACRAMENTO CITY UNIFIED SCHOOL
DISTRICT**

By: _____

By: _____

Title: _____

Title: _____

NOTE: If the party executing this Contract is a corporation, a certified copy of the by-laws, or of the resolution of the Board of Directors, authorizing the officers of said corporation to execute the Contract and the bonds required thereby must be attached hereto.

END OF DOCUMENT

1.03 CONSTRUCTION SCHEDULE

- A. Within ten (10) days of issuance of the Notice to Proceed and before request for first progress payment, the Contractor shall prepare and submit to the Project Manager a construction progress schedule conforming to the Milestone Schedule below.
- B. The Construction Schedule shall be continuously updated, and an updated schedule shall be submitted with each application for progress payment. Each revised schedule shall indicate the work actually accomplished during the previous period and the schedule for completion of the remaining work.
- C. Milestone Schedule:

Preliminary Construction Schedule

Anticipated Notice of Intent to Award (NOITA)	05/20/22
Anticipated Board Approval of Construction Contract	06/02/22
Anticipated Notice to Proceed (NTP)	06/03/22
Shop Drawings, Submittals, Materials Procurement	06/03/22 - 06/16/22

Site Construction Schedule

Last Day of 2021-2022 School	06/16/22
First Day of 2022-23 School	8/25/22
Mobilization and Start of Construction	06/17/22

Site-Adaption Construction Phase – Completion 8/20/22

Work prior to install of Shade Structures to include, but not limited to HAZMAT, Utilities, Electrical Rough-in, ADA improvements, concrete footings & pads. Contractor to include the pick-up of anchor bolts from District storage – location TBD

Site Adaptation Phase Punch & Corrective work	8/20/22 – 8/24/22
Milestone Completion Date of All Site Adaptation work	8/24/2022
Anticipated Shipments of OFCI Shade Structures	8/19/22 – 9/9/22

Start of OFCI Shade Structure Install Phase

Delivery Dates - TBD

Install timeframe of Each Structure: No more than 5 days unless given authorization by District. Complete work on swing shift, after school hours. Provide temporary fencing around work area at all times through completion.

Punch List, Corrective Work & Final Cleaning	10/15/22 – 10/30/22
--	---------------------

FINAL PROJECT COMPLETION **December 31, 2022**

PART 1 - GENERAL

1.1 SUMMARY

- A. Section Includes:
 - 1. Sealants and backing for interior and exterior joints.

1.2 RELATED REQUIREMENTS

- A. Section 01 6116, Volatile Organic Compound (VOC) Restrictions, for VOC limits pertaining to adhesives, sealants, fillers, primers, and coatings.
- B. Pertinent Sections specifying sealants or referencing this Section for sealant products and installation requirements.

1.3 REFERENCES AND STANDARDS

- A. California Building Code (CBC), edition as noted on Drawings.
- B. California Green Building Standards Code (CAL Green), edition as noted on Drawings.
- C. American Concrete Institute (ACI) Publications and Standards:
 - 1. ACI 302.1R: Guide to Concrete Floor and Slab Construction.
 - 2. ACI 360R-10: Guide to Design of Slabs-on-Ground.
- D. ASTM International (ASTM):
 - 1. C834: Standard Specification for Latex Sealants.
 - 2. C919: Standard Practice for Use of Sealants in Acoustical Applications.
 - 3. C920: Standard Specification for Elastomeric Joint Sealants.
 - 4. C1193: Standard Guide for Use of Joint Sealants.
 - 5. C1247: Standard Test Method for Durability of Sealants Exposed to Continuous Immersion in Liquids.
 - 6. C1248: Standard Test Method for Staining of Porous Substrate by Joint Sealants.
 - 7. C1311: Standard Specification for Solvent Release Sealants.
 - 8. C1330: Standard Specification for Cylindrical Sealant Backing for Use with Cold Liquid-Applied Sealants.
 - 9. C1521: Standard Practice for Evaluating Adhesion of Installed Weatherproofing Sealant Joints.
 - 10. D1667: Standard Specification for Flexible Cellular Materials - Poly (Vinyl Chloride) Foam (Closed-Cell).
 - 11. E90: Standard Test Method for Laboratory Measurement of Airborne Sound Transmission Loss of Building Partitions and Elements.
- E. Federal Specifications (FS):

JOINT SEALANTS
SECTION 07 9200
21-1504

1. FS TT-S-001657: Sealing Compound--Single Component, Butyl Rubber Based, Solvent Release Type.

F. South Coast Air Quality Management District (SCAQMD):

1. Rule 1168: Adhesive and Sealant Applications.

G. U.S. Food & Drug Administration (FDA):

1. Code of Federal Regulations: Title 21, 21 CFR 177.2600, Rubber Articles Intended for Repeated Use.

1.4 DEFINITIONS

A. Sealant Terminology in accordance with ASTM C834 and ASTM C920:

1. Type C: Clear / translucent sealant.
2. Type OP: Opaque pigmented sealant.
3. Type S: Single component sealant.
4. Type M: Sealant with two or more components.
5. Grade NS: Nonsag sealant.
6. Grade P: Pourable sealant.
7. Grade -18°C: Sealant with low temperature flexibility tested to -18°C (0°F).
8. Grade 0°C: Sealant with low temperature flexibility tested to 0°C (32°F).
9. Grade NF: Sealant does not meet low temperature flexibility requirements.
10. Class 12-1/2: Sealant capable of handling movement, either contraction or expansion, of 12.5 percent of the original joint width.
11. Class 25: Sealant capable of handling movement, either contraction or expansion, of 25 percent of the original joint width.
12. Class 35: Sealant capable of handling movement, either contraction or expansion, of 35 percent of the original joint width.
13. Class 50: Sealant capable of handling movement, either contraction or expansion, of 50 percent of the original joint width.
14. Class 100 / 50: Sealant capable of handling movement of 50 percent contraction and 100 percent expansion.
15. Use Related to Exposure:
 - a. Use NT: Nontraffic.
 - b. Use T: Traffic.
 - c. Use I: Immersible.
16. Use Related to Material:
 - a. Use A: Sealant used in contact with aluminum.
 - b. Use G: Sealant used in contact with glass.
 - c. Use M: Sealant used in contact with mortar.
 - d. Use O: Sealants used in contact with all other materials other than those previously listed.

1.5 ADMINISTRATIVE REQUIREMENTS

- A. Submittal Procedures:
 - 1. Action Submittals and Informational Submittals shall be submitted in accordance with Section 01 3300, Submittal Procedures.
 - 2. Closeout Submittals shall be submitted in accordance with Section 01 7700, Closeout Procedures.
- B. Pre-Installation Meeting: Conduct at Project site. Review joint application procedures, compatibility tests, adhesion tests, and warranty requirements in a meeting involving Architect, Project Inspector, installer, manufacturer or manufacturer's representative.
- C. Coordination:
 - 1. Use of different manufacturer's sealant types for application at exterior wall and glazing systems is not permitted. It is required that a single source for silicone sealants be used on this Project. The Contractor is responsible for coordinating compliance with this requirement where installation of sealants is delegated to various Subcontractors installing the exterior envelope systems for the Project.
 - 2. Contractor shall coordinate and be responsible for compatibility and performance between sealants and other materials, and related Sections using sealants which may be in direct contact with work of this Section or adjacent to the other. Isolate and prevent of incompatibility between sealants in accordance with manufacturer's specifications, recommendations and instructions.

1.6 ACTION SUBMITTALS

- A. Product Data: For each type of product indicated, demonstrate compliance with specified attributes.
 - 1. Include color chart from manufacturers for each joint sealant product required.
 - 2. Provide certification by joint sealant manufacturer that materials provided for this Section are 100 percent asbestos-free.
- B. Samples for initial Selection: In form of manufacturer's standard bead samples, consisting of strips of actual products showing full range of colors available, for each product exposed to view.
- C. Samples for Verification: For each kind and color of joint sealant required, provide Samples with joint sealants in 1/2 inch wide joints formed between two 6 inch long strips of material matching the appearance of exposed surfaces adjacent to joint sealants.

1.7 INFORMATIONAL SUBMITTALS

- A. Qualification Data: For Installer.
- B. Product Certificates: For each kind of joint sealant and accessory, from manufacturer.
- C. Product Test Reports: Based on evaluation of comprehensive tests performed by a qualified testing agency, indicating that sealants comply with requirements.

JOINT SEALANTS
SECTION 07 9200
21-1504

1. Preconstruction Compatibility and Adhesion Test Reports from sealant manufacturer, indicating the following:
 - a. Materials forming joint substrates and joint-sealant backings have been tested for compatibility and adhesion with joint sealants.
 - b. Interpretation of test results and written recommendations for primers and substrate preparation needed for adhesion.

- D. Sustainable Design:
 1. General:
 - a. Submit information necessary to establish and document compliance with the California Green Building Standards Code.
 2. The following information shall be provided:
 - a. Adhesives and Sealants: Evidence of compliance that products meet maximum VOC content limits specified in Section 01 6116.

- E. Sample of manufacturer's warranty.

1.8 CLOSEOUT SUBMITTALS

- A. Warranty and Guarantee: Submit executed warranty and extended Contractor guarantee.

1.9 QUALITY ASSURANCE

- A. Installer Qualifications: Manufacturer's authorized representative who is trained and approved for installation of sealants and backing required for this Project.
- B. Use only new materials and products, unless existing materials or products are specifically shown otherwise on the Drawings to be salvaged and re-used.
- C. Single Source Responsibility: Obtain each kind of joint sealant from single source from single manufacturer.
- D. Materials, components, assemblies, workmanship and installation are to be observed by the Project Inspector. Work not so inspected is subject to uncovering and replacement.
- E. Mockups: Install sealant in mockups of assemblies specified in other Sections that are indicated to receive joint sealants specified in this Section. Use materials and installation methods specified in this Section.

1.10 DELIVERY, STORAGE AND HANDLING

- A. Deliver materials to project site in original factory wrappings and containers, labeled with identification of manufacturer, product name and designation, color, expiration period for use, pot life, curing time, and mixing instructions for multicomponent materials.
- B. Store and handle materials in compliance with manufacturer's recommendations to prevent their deterioration or damage due to moisture, high or low temperatures, contaminants, or other causes.

1.11 FIELD CONDITIONS

- A. Environmental Conditions: Do not proceed with installation of joint sealants under the following conditions:
 - 1. When ambient and substrate temperature conditions are outside the limits permitted by joint sealant manufacturer.
 - 2. When joint substrates are wet.
- B. Joint Width Conditions: Do not proceed with installation of joint sealants where joint widths are less than allowed by joint sealant manufacturer for application indicated.
- C. Joint Substrate Conditions: Do not proceed with installation of joint sealants until contaminants capable of interfering with their adhesion are removed from joint substrates.

1.12 WARRANTY AND GUARANTEE

- A. Manufacturer: In addition to the Contractor's and Subcontractor's Standard Guarantee, furnish Owner with manufacturer's fully executed written warranty for sealant against defects in materials and workmanship for a period of 5 years:
- B. Contractor: in addition to its standard Guarantee under the Contract, furnish Owner a special extended written five-year guarantee, cosigned by installer, for sealant, agreeing to replace any and all joints that leaks or otherwise fails to perform as required within guarantee period as a result of failure of materials or installation workmanship at no additional cost to the Owner.

PART 2 - PRODUCTS

2.1 DESIGN AND PERFORMANCE CRITERIA

- A. Sustainable Design:
 - 1. VOC emissions for field-applied adhesives, sealants, and sealant primers must comply with limits specified in Section 01 6116.
- B. Building Envelope: Make watertight and weatherproof.
 - 1. Exterior work that does not remain watertight and all work which does not retain all properties inherent in the product as stipulated by the manufacturer will be considered faulty.
- C. Provide elastomeric joint sealants that have been produced and installed to establish and to maintain watertight and airtight continuous seals without causing staining or deterioration of joint substrates.
- D. Provide joint sealants for interior applications that have been produced and installed to establish and maintain airtight continuous seals that are water resistant and cause no staining or deterioration of joint substrates.

JOINT SEALANTS
SECTION 07 9200
21-1504

E. Design Requirements:

1. Seal building joints with non-sag type sealant.
2. Seal floor joints with self-leveling or slope grade self-leveling type sealant.

2.2 MATERIALS, GENERAL

A. Compatibility: Provide joint sealants, joint fillers, and other related materials that are compatible with one another and with joint substrates under conditions of service and application, as demonstrated by sealant manufacturer based on testing and field experience.

B. Liquid-Applied Joint Sealants: Comply with ASTM C920 and other requirements indicated for each liquid-applied joint sealant specified, including those referencing ASTM C920 classifications for type, grade, class, and uses related to exposure and joint substrates.

1. Suitability for Immersion in Liquids. Where sealants are indicated for Use I for joints that will be continuously immersed in liquids, provide products that have undergone testing according to ASTM C 1247. Liquid used for testing sealants is deionized water, unless otherwise indicated.

C. Colors:

1. General:

- a. Match adjacent surfaces.
- b. Not all locations will have the same color.

2. Provide color of exposed joint sealants to comply with the following:

- a. Provide colors matching selections made by Architects from manufacturer's full range of colors for products of type indicated.
- b. Request color selection for exposed products listed without a preselected color.

2.3 SILICONE JOINT SEALANTS

A. Single-Component, Nonsag, Neutral-Curing Silicone Joint Sealant: ASTM C920, Type S, Grade NS, Class 100 / 50, for Use NT.

1. Products: The following, or equal:

- a. The Dow Chemical Company; "DOWSIL" 790.
- b. Sika Corporation, Construction Products Division; "Sikasil" WS-290.

B. Single-Component, Nonsag, Neutral-Curing Silicone Joint Sealant: ASTM C920, Type S, Grade NS, Class 50, for Use NT.

1. Products: The following, or equal:

- a. Dow Corning Corporation; "DOWSIL 795 Building Sealant".
- b. Sika Corporation, Construction Products Division; "Sikasil WS-295."

- C. Single-Component, Nonsag, Non-Bleed, Neutral-Curing Silicone Joint Sealant: ASTM C920, Type S, Grade NS, Class 50, for Use G, M, A and O.
 - 1. Products: The following, or equal:
 - a. The Dow Chemical Company; "DOWSIL 756 SMS."
 - b. Momentive Performance Materials; "SCS9000 SilPruf NB."
- D. Single-Component, Nonsag, One Part RTV Neutral-Curing Silicone Joint Sealant: ASTM C920, Type S, Grade NS, Class 25, designed for adhering to low energy surfaces common in sheet or peel and stick weather resistant barriers.
 - 1. Products: The following, or equal:
 - a. The Dow Chemical Company; "DOWSIL" 758.
 - b. Sika Corporation, Construction Products Division; "Sikasil-N Plus."
- E. Mildew-Resistant, Single-Component, Acid-Curing Silicone Joint Sealant: ASTM C920, Type S, Grade NS, Class 25, for Use NT, A and O.
 - 1. Products: The following, or equal:
 - a. The Dow Chemical Company; "DOWSIL 786 Mildew Resistant."
 - b. Momentive Performance Materials; GE Silicones "Sanitary SCS1700."

2.4 URETHANE JOINT SEALANTS

- A. Single-Component, Nonsag, Urethane Joint Sealant: ASTM C920, Type S, Grade NS, Class 35, for Use NT.
 - 1. Products: The following, or equal:
 - a. BASF Master Builders Solutions; "MasterSeal NP 1."
 - b. Sika Corporation, Construction Products Division; "Sikaflex-1a."
- B. Multicomponent, Nonsag, Urethane Joint Sealant: ASTM C920, Type M, Grade NS, Class 25, for Use NT, M, A and O.
 - 1. Products: The following, or equal:
 - a. BASF Master Builders Solutions; "MasterSeal NP 2."
 - b. Sika Corporation, Construction Products Division; "Sikaflex-2c NS."
- C. Multicomponent Urethane Joint Sealant: ASTM C920; self-leveling, Type M, Grade P, Class 25, Uses T, M, A, O, and approved by manufacturer for wide joints up to 1-1/2 inches.
 - 1. Products: The following or equal:
 - a. BASF Master Builders Solutions; "MasterSeal SL 2."
 - b. Sika Corporation, Construction Products Division; "Sikaflex 2c SL."

JOINT SEALANTS

SECTION 07 9200

21-1504

2.5 ACRYLIC LATEX JOINT SEALANTS

- A. Latex Joint Sealant: Acrylic latex or siliconized acrylic latex, nonsag, paintable, nonstaining. ASTM C 834, Type OP, Grade NF.
 - 1. Products: The following, or equal:
 - a. Pecora Corporation; "AC-20."
 - b. Sherwin Williams; 950A.

2.6 JOINT SEALANT BACKING

- A. General: Provide sealant backings of material and type that are nonstaining; are compatible with joint substrates, sealants, primers and other joint fillers; and are approved for applications indicated by sealant manufacturer based on field experience and laboratory testing.
- B. Cylindrical Sealant Backer Rods: Compressible, non-gassing rod-stock complying with ASTM C1330; polyethylene-jacketed polyurethane foam; butyl-rubber foam; neoprene foam; or other flexible, permanent, durable, non-absorptive closed-cell (Type C), open cell (Type O), or bi-cellular material (Type B) and of size and density to control sealant depth and otherwise contribute to producing optimum sealant performance.
 - 1. Open cell rods shall not be used at sealant joints for horizontal surfaces.
 - 2. Closed cell rods shall not be used at double sealant joints.
- C. Bond-Breaker Tape: Polyethylene tape or other plastic tape as recommended by sealant manufacturer for preventing sealant from adhering to rigid, inflexible joint filler materials or joint surfaces at back of joint where such adhesion would result in sealant failure. Provide self-adhesive tape where applicable.

2.7 SEALANT ACCESSORIES AND ADDITIONAL MATERIALS

- A. Primer: Material recommended by joint sealant manufacturer where required for adhesion of sealant to joint substrates indicated, as determined from preconstruction joint sealant-substrate tests and field tests.
- B. Cleaners for Nonporous Surfaces: Chemical cleaners acceptable to manufacturers of sealants and sealant backing materials, free of oily residues or other substances capable of staining or harming in any way joint substrates and adjacent nonporous surfaces, and formulated to promote optimum adhesion of sealants with joint substrates.
- C. Masking Tape: Nonstaining, nonabsorbent material compatible with joint sealants and surfaces adjacent to joints.
- D. Spall Repair Mortar: Two-component structural epoxy binder and sand aggregate, producing a mortar that is easily worked and troweled. Early-set system designed specifically for the repair of industrial concrete floors subject to hard wheeled traffic. Compatible with joint filler and recommended by the joint filler manufacturer in writing.
 - 1. Products: The following, or equal:
 - a. Metzger/McGuire: "Armor-Hard."

PART 3 - EXECUTION

3.1 EXAMINATION

- A. Examine joints indicated to receive joint sealants, with Installer present, for compliance with requirements for joint configuration, installation tolerances, and other conditions affecting joint sealant performance. Do not proceed with installation of joint sealants until unsatisfactory conditions have been corrected.
- B. Commencement of work indicates acceptance of substrates.

3.2 PREPARATION

- A. Surface Cleaning of Joints: Clean out joints immediately before installing joint sealants to comply with recommendations of joint sealant manufacturer and the following requirements:
 - 1. Remove foreign material from joint substrates that could interfere with adhesion of joint sealant, including dust, paints (except for permanent, protective coatings tested and approved for sealant adhesion and compatibility by sealant manufacturer), old joint sealants, oil, grease, waterproofing, water repellents, water, surface dirt, and frost.
 - 2. Clean concrete, masonry, unglazed surfaces of ceramic tile, and similar porous joint substrate surfaces by brushing, grinding, blast cleaning, mechanical abrading, or a combination of these methods to produce a clean, sound substrate capable of developing optimum bond with joint sealants. Remove loose particles remaining from above cleaning operations by vacuuming or blowing out joints with oil-free compressed air.
 - 3. Remove laitance and form release agents from concrete.
 - 4. Clean metal, glass, porcelain enamel, glazed surfaces of ceramic tile, and other nonporous surfaces with chemical cleaners or other means that do not stain, harm substrates, or leave residues capable of interfering with adhesion of joint sealants.
- B. Spall Repair: Repair spalled joints in concrete slabs to produce joints of profiles recommended by joint sealer manufacturers.
- C. Joint Priming:
 - 1. Prime joint substrates where indicated or where recommended by joint sealant manufacturer based on preconstruction joint sealant-substrate tests or prior experience.
 - 2. Apply primer to comply with joint sealant manufacturer's recommendations. Confine primers to areas of joint sealant bond; do not allow spillage or migration onto adjoining surfaces.
- D. Masking Tape:
 - 1. Use masking tape where required to prevent contact of sealant with adjoining surfaces that otherwise would be permanently stained or damaged by such contact or by cleaning methods required to remove sealant smears.

JOINT SEALANTS
SECTION 07 9200
21-1504

2. Remove tape immediately after tooling without disturbing joint seal.

3.3 INSTALLATION OF JOINT SEALANTS

A. General:

1. Comply with joint sealant manufacturer's printed installation instructions applicable to products and applications indicated, except where more stringent requirements apply.
2. Seal around penetrations, holes, gaps, surface mounted fixtures and pipes entering building including light fixtures, mounting brackets and other similar items.

B. Sealant Installation Standard: Comply with recommendations of ASTM C1193 for use of joint sealants as applicable to materials, applications, and conditions indicated.

C. Joint Sealants at Building Exterior and Interior:

1. Seal the following joints with joint sealant:
 - a. Joints between dissimilar materials.
 - b. Joints between metal panels.
 - c. Control joints in interior partitions, including portion above ceilings.
 - d. Where shown and noted on the documents.
2. Apply joint sealant at joints not specifically mentioned above which require sealant to meet the performance criteria cited in this Section.

D. Installation of Sealant Backer Rods: Install sealant backer rods to comply with the following requirements:

1. Install joint fillers of type indicated to provide support of sealants during application and at position required to produce the cross-sectional shapes and depths of installed sealants relative to joint widths that allow optimum sealant movement capability.
 - a. Do not leave gaps between ends of joint fillers.
 - b. Do not stretch, twist, puncture, or tear joint fillers.
 - c. Remove absorbent joint fillers that have become wet prior to sealant application and replace with dry material.
2. Install bond breaker tape between sealants where backer rods are not used between sealants and joint fillers or back of joints.

E. Sealant Installation:

1. Install sealants by proven techniques that result in sealants directly contacting and fully wetting joint substrates, completely filling recesses provided for each joint configuration, and providing uniform, cross-sectional shapes and depths relative to joint widths that allow optimum sealant movement capability.
2. Install sealants at the same time sealant backings are installed.

F. Tooling of Nonsag Sealants:

1. Immediately after sealant application and prior to time skinning or curing begins, tool sealants to form smooth, uniform beads of configuration indicated, to eliminate air pockets, and to ensure contact and adhesion of sealant with sides of joint. Remove excess sealants from surfaces adjacent to joint.
2. Do not use tooling agents that discolor sealants or adjacent surfaces or are not approved by sealant manufacturer.
3. Profiles:
 - a. Provide concave joint configuration in accordance with Figure 8A in ASTM C1193, unless otherwise indicated.
 - b. Provide flush joint configuration in accordance with Figure 8B in ASTM C1193, where indicated.
 - c. Provide recessed joint configuration in accordance with Figure 8C in ASTM C1193, of recess depth and at locations indicated.
 - 1) Use masking tape to protect adjacent surfaces of recessed tooled joints.

3.4 DEFECTIVE WORK

- A. Repair damaged and defective work and eliminate functional and visual defects. Where repair is not possible replace work. Adjust joints for uniform appearance.
- B. Cut out and remove damaged or deteriorated joint sealants immediately so that and installations with repaired areas are indistinguishable from original work.

3.5 CLEANING AND PROTECTION

- A. Clean off excess sealants or sealant smears adjacent to joints as work progresses by methods and with cleaning materials approved by manufacturers of joint sealants and of products in which joints occur.
- B. Clean excess adhesive from exposed surfaces of neoprene compression seal with solvent cleaner as recommended by manufacturer.
- C. Protect joint sealants during and after curing period from contact with contaminating substances or from damage resulting from construction operations or other causes so that they are without deterioration or damage at time of Substantial Completion.

3.6 SEALANT SCHEDULE

- A. General:
 1. Joints in construction between interior and exterior spaces and other designated or required locations to provide effective barrier against passage of elements:
 - a. Multicomponent, Nonsag, Urethane Joint Sealant: ASTM C920, Type M, Grade NS, Class 25, for Use NT, M, A and O.
 - b. Single-Component, Nonsag, Urethane Joint Sealant: ASTM C920, Type S, Grade NS, Class 25, for Use NT.
 2. Specialty perimeters where required for appearance or weather tightness:

JOINT SEALANTS
SECTION 07 9200
21-1504

- a. Multicomponent, Nonsag, Urethane Joint Sealant: ASTM C920, Type M, Grade NS, Class 25, for Use NT, M, A and O; capable of 50 percent extension and compression movement.
- b. Single-Component, Nonsag, Urethane Joint Sealant: ASTM C920, Type S, Grade NS, Class 35, for Use NT.
- c. Single-Component, Nonsag, Neutral-Curing Silicone Joint Sealant: ASTM C920, Type S, Grade NS, Class 50, for Use NT.
- d. Single-Component, Nonsag, Neutral-Curing Silicone Joint Sealant: ASTM C920, Type S, Grade NS, Class 100 / 50, for Use NT.

B. Exterior Locations:

1. All Exterior Joints:

- a. Single-component, nonsag, neutral-curing silicone joint sealant, ASTM C920, Type S, Grade NS, Class 100 / 50, for Use NT.
- b. Single-component, nonsag, neutral-curing silicone joint sealant, ASTM C920, Type S, Grade NS, Class 50, for Use NT.
- c. Around perimeters of frames where door, window and louver frames abut concrete, masonry or other building materials.
- d. Expansion and control joints in masonry.
- e. Masonry at dissimilar material or at dissimilar masonry.
- f. Miscellaneous locations where sealant is shown on Drawings.

C. Interior Locations:

1. Interior Wet Areas, Around Plumbing Fixtures, Mildew-resistant, single-component, acid-curing silicone joint sealant, ASTM C920, Type S, Grade NS, Class 25, for Use NT, A and O.
2. Interior Static Dry Joints as Required to Dress Appearance: Acrylic latex or siliconized acrylic latex joint sealant, ASTM C 834, Type OP, Grade NF

END OF SECTION

PART 1 - GENERAL

1.1 SUMMARY

- A. Section Includes: Painting and painter's finish on all exposed exterior and interior surfaces, except prefinished items and unless otherwise noted, as required to complete finishing of the Work. The Work includes, but is not necessarily limited to, the following specific items:
 - 1. Paint, stain or otherwise finish all new surfaces.
 - 2. Back priming of concealed surfaces, except as otherwise specified.
 - 3. Paint, repaint or finish of existing painted surfaces altered, defaced or damaged as a result of work of this Contract.
 - 4. Paint site items which are not prefinished, including posts, screens, panels, bollards, supports, rails and other similar improvements.
 - 5. Unpainted or unfinished exposed building components, pipes and conduit, which run exposed across finished or painted surfaces.
- B. Surface treatment, priming and coats of paint specified in this Section are in addition to shop priming and surface treatment specified under other Sections unless otherwise noted.
- C. Items Not Included in This Section:
 - 1. Factory and shop-prefinished items as specified in various Sections.
 - 2. Painting specified elsewhere and included in respective Sections, including but not necessarily limited to shop priming.

1.2 WORK NOT TO BE PAINTED UNLESS OTHERWISE INDICATED

- A. Exposed exterior concrete and concrete slab surfaces, except as noted.
- B. Unfinished masonry, except where noted.
- C. Suspended acoustical ceilings and acoustical tile, except as noted.
- D. Pre-finished casework and other factory and shop-prefinished items as specified in various Sections.
- E. Finish hardware except prime coated items.
- F. Items typically not to be painted including, but not limited to, the following:
 - 1. Glass.
 - 2. Ceramic tile.
 - 3. Membrane roofing.
 - 4. Safety nosings.

PAINTING
SECTION 09 9100
21-1504

5. Resilient floor covering and base.
 6. Carpet.
 7. Pre-finished paneling.
 8. Plastic laminate.
 9. Porcelain enamel.
 10. Vinyl wallcovering, except where noted.
- G. Aluminum doors, windows, frames and railings.
- H. Metal or plastic toilet partitions.
- I. Items of chromium, copper, nickel, brass, bronze or stainless steel.
- J. Surfaces in concealed areas such as furred spaces.
- K. Tops of gravel stop flanges (including priming) where roofing material will be adhered to.
- L. Wall areas concealed by cases, counters, cabinets, chalkboards, tackboards (prime coat only required).
- M. Piping or conduit including brackets and similar items therewith running on or across unpainted or otherwise unfinished walls or ceilings.
- N. Galvanized gratings, recessed foot grilles, and thresholds.
- O. Structural steel scheduled to receive fireproofing.
- P. Existing rooms or areas not affected by work of this project, unless specifically noted otherwise.

1.3 RELATED REQUIREMENTS

- A. Section 01 6116, Volatile Organic Compound (VOC) Restrictions; for VOC limits pertaining to adhesives, sealants, fillers, primers, and coatings.
- B. Section 05 5000, Metal Fabrications.
- C. Section 07 9200, Joint Sealants.
- D. Section 26 0150, Electrical Basic Materials and Methods

1.4 REFERENCES AND STANDARDS

- A. California Building Code (CBC), edition as noted on the Drawings.
- B. California Green Building Standards Code (CAL Green), edition as noted on the Drawings.
- C. ASTM International (ASTM):
 1. D523: Standard Test Method for Specular Gloss.

2. D4263: Standard Test Method for Indicating Moisture in Concrete by the Plastic Sheet Method.

D. Master Painters Institute (MPI):

1. Architectural Painting Manual Guide Specification.

1.5 ADMINISTRATIVE REQUIREMENTS

A. Submittal Procedures:

1. Action Submittals and Informational Submittals shall be submitted in accordance with Section 01 3300, Submittal Procedures.
2. Closeout Submittals shall be submitted in accordance with Section 01 7700, Closeout Procedures.

1.6 ACTION SUBMITTALS

- A. Product Data: Submit list and complete descriptive data of products proposed for use. Include manufacturer's specifications, published warranty or guarantee, and application instructions. Cross-reference to paint system and locations of application areas.

1.7 INFORMATIONAL SUBMITTALS

- A. Statement of applicator qualifications.

1.8 CLOSEOUT SUBMITTALS

- A. Guarantee: Submit Subcontractor's guarantee.

1.9 MAINTENANCE MATERIAL SUBMITTALS

- A. At completion of the Work, deliver to Owner extra stock of paint of each color used in each coating material used.
- B. Containers shall be full, tightly sealed, and clearly marked.

1.10 QUALITY ASSURANCE

- A. Use only new materials and products.
- B. Single-Source Responsibility:
1. To the maximum extent practicable, select a single manufacturer to provide all materials required by this Section, using additional manufacturers to provide systems not offered by the selected principal manufacturer.
 2. For each individual system:
 - a. Provide primer and other undercoat paint produced by same manufacturer as finish coat.
 - b. Use thinner within manufacturer's recommended limits.

PAINTING
SECTION 09 9100
21-1504

- C. Source Quality Control: Material shall be best grade products of type specified and listed below as regularly manufactured by these manufacturers. Materials not bearing manufacturer's identification as standard "best grade product" of their regular line will not be considered for use.
- D. Materials, components, assemblies, workmanship and installation are to be observed by the Owner's Project Inspector. Work not so inspected is subject to uncovering and replacement.
- E. Materials and application procedures shall comply with local, state and federal air pollution control regulations.
- F. Manufacturer's representative from coating supplier shall visit the site prior to application to review and approve the specified systems. Discrepancies or recommended changes shall be submitted to the Architect for consideration prior to finalization of submittal.

1.11 DELIVERY, STORAGE AND HANDLING

- A. Deliver undamaged products to job in manufacturer's sealed containers and/or original bundles with tags and labels intact.
- B. Store materials in protected, clean, dry conditions off of ground and in areas which will not interfere with the progress of the Work.
- C. Transport, store and handle in strict accordance with the manufacturer's written recommendations and as specified below.
- D. Remove paint-soiled rags and waste from premises at end of each day's work or store in metal containers with metal covers.
- E. Paint stored at site, shall be in separate structure not less than 60 feet from any other building or structure. Remove empty containers and soiled rags as they accumulate. At completion, remove structure, cleanup area, and leave in original condition.

1.12 FIELD CONDITIONS

- A. Do not apply paints and coatings under conditions which jeopardize quality or appearance of painting or finishing.
- B. Cover or otherwise protect finished work of other trades and surfaces not being painted concurrently or not to be painted.
- C. Exterior:
 - 1. Comply with manufacturer's recommendations as to environmental conditions under which coatings and coating systems can be stored and applied.
 - 2. Do not apply exterior paint when air or surface temperature is under 50 degrees F or when air or surface temperature will be below 50 degrees F for 48 hours after painting.
 - 3. Do not apply immediately following snow, rain, dew or during foggy weather.

4. Do not apply when temperature is over 85 degrees F except in protected or shaded areas.
- D. Interior:
1. Do not apply interior paint when air or surface temperature is below 50 degrees F unless temperature is maintained constantly.
 2. Do not apply when ventilation is inadequate to maintain humidity lower than dew point of coldest wall.
- E. Use moisture meter for determining proper moisture levels of surfaces for painting.
- F. Report to Architect in writing upon discovery of any prime coat painting specified in other Sections of Specifications that would prevent proper application of specified finish.
- G. Furnish, erect and remove scaffolding and planks required for work under this Section. Conform to state and local codes, rules and regulations.

1.13 EXISTING CONDITIONS

- A. Existing Surfaces:
1. Paint, stain or otherwise finish all existing surfaces as indicated or scheduled on the Drawings.
 2. Work includes primer, paint, repaint or finish of existing painted surfaces altered, defaced or damaged as a result of work under this Contract.
- B. Existing surfaces with paint, stain, varnish or similar type coating shall be assumed to contain various concentrations of lead. Cal/OSHA regulations are therefore applicable during disturbance, preparation or repainting of these surfaces.
- C. Existing surfaces to be painted include:
1. Exterior wall surfaces, including fascia, trim.
 2. Soffits and exterior ceilings including exposed roof framing.
 3. Concrete foundation where exposed below painted wall surfaces.
 4. Other work as shown on the Drawings, specified, or as required for a complete Project.

1.14 GUARANTEE

- A. Contractor: In addition to his standard Guarantee under the Contract, Contractor shall guarantee that paint colors shall be substantially unchanged and finishes shall maintain their original adherence without showing blisters, flaking, peeling, scaling, staining or unusual deterioration or other defects.

PAINTING
SECTION 09 9100
21-1504
PART 2 - PRODUCTS

2.1 DESIGN AND PERFORMANCE CRITERIA

- A. Sustainable Design:
 - 1. VOC emissions for field-applied paints and coatings must comply with limits specified in Section 01 6116.

2.2 MANUFACTURERS AND COATING PRODUCTS

- A. Products are specified under "Paint Systems" in Part 3 below and are manufactured by Kelly-Moore, except as otherwise indicated. Equivalent products to those scheduled manufactured by PPG Architectural Finishes, Glidden Professional, Benjamin Moore & Co., Sherwin-Williams, Dunn-Edwards, Vista, or equal are acceptable.
- B. Materials selected for coating systems for each type surface shall be the product of a single manufacturer or shall be acceptable to manufacturer of finish coating for system.
- C. If more than one quality level of product type is marketed, use material of highest quality.

2.3 MIXING AND TINTING

- A. Deliver paints and stains ready mixed to jobsite. On-site color mixing or tinting will not be allowed.
- B. Each kind of coating for paint finishes shall be factory-mixed to match approved samples, colors, and ready for immediate application.
- C. Mix proprietary products in strict accordance with manufacturer's printed directions.
- D. Thinning, if permitted by manufacturer for a specific coating, shall be in accordance with manufacturer's instructions. Thinning of other products shall be in accordance with standard practice.

2.4 COLORS

- A. Colors to match existing adjacent surfaces.

PART 3 - EXECUTION

3.1 EXAMINATION

- A. Prior to the work of this Section, carefully inspect and verify that the installed work of all other trades is complete to the point where this work may properly commence.
- B. Verify that painting may be performed in accordance with the approved design.
- C. In the event of discrepancy, immediately notify Architect. Do not proceed in discrepant areas until discrepancies have been fully resolved.

3.2 PREPARATION

A. General:

1. Surface preparation and product application shall be in accordance with manufacturer's printed instructions.
2. In addition to prime coats indicated (primer, sealer, filler, undercoat), use two (2) finish coats minimum, and additional coats as required for complete coverage and good appearance of scheduled finish coat.
3. Surfaces to receive new finish shall be properly prepared prior to application of finish coatings.
4. Do not apply paint, enamel, stains or varnishes to wet, damp, dusty, finger-marked, rough, unfinished, or defective surfaces until such defects have been corrected.

B. Wood - Interior:

1. Thoroughly sandpaper and dust off woodwork; putty nail holes, cracks, and other defects after first coat to match color of paint. Putty where finish will be clear.
2. First coat on wood surfaces shall be sanded smooth. Other coats, except finish coat, shall be lightly sanded and dusted before and between each coat.
3. Smoothing, rubbing and sand-papering shall be sufficient to insure good results. Sand down all raised grain or rough surfaces and re-coat. Knots, pitch pockets and sappy portion of wood, all nail holes, cuts, cracks and other defects in wood shall have any necessary extra treatment to provide proper paint base.

C. Wood – Exterior:

1. Surfaces shall be dry and free of grease and splatters.
2. Rough surfaces shall be sanded smooth. **[Do not sandpaper resawn surfaces.]**
3. At opaque finish, fill nail holes, cracks, open joints, and other defects with filler after priming coat has dried. Exposed nail heads shall be spot primed.
4. Avoid painting surfaces while exposed directly to hot sun.
5. Smooth surfaces shall be sanded thoroughly to allow proper penetration and adhesion. Areas exhibiting tannic acid staining shall receive two coats of primer waiting 24 hours between coats. Sand and prime as soon as possible after installation to avoid UV degradation of unpainted wood surface.
6. Mildew, if present, shall be removed by scrubbing with a commercial mildew wash in accordance with manufacturer's directions.

D. Metals:

1. On metal work, only such sanding will be required as is necessary to provide for complete bonding of coats.
2. Steel and ironwork shall be scraped clean of scale, and rust and any grease shall be entirely removed.
3. Touch-up scratched and damaged places on metal priming coats.

PAINTING
SECTION 09 9100
21-1504

4. Galvanized or zinc-coated metal shall be given an approved acid treatment 48 hours before paint is applied.
5. Prep and prime coat factory or shop primed metal products, including metal doors and frames, exposed framing, and other exposed metal if material was not shop primed.
6. Metal surfaces receiving epoxy coatings shall have stripe coat applied at all welds, edges, joints, etc., with epoxy primer prior to application of primer.

E. Gypsum Board:

1. General:
 - a. Fill narrow, shallow cracks and small holes with spackling compound.
 - 1) Rake deep, wide cracks and deep holes.
 - 2) Dampen with clear water.
 - b. Fill with thin layers of drywall joint cement.
 - c. Allow to dry.
 - d. Sand smooth after drying. Do not raise nap of paper on gypsum board.]
2. Gypsum Board to Receive Wall Covering and Carpeting:
 - a. Prep and prime surfaces scheduled to receive wall covering with scheduled primer. Refer to Section 09 7200, Wall Covering, for clear acrylic primer to be used at vinyl wall covering.
 - b. Sprayed applications of primer shall be back rolled to assure that the primer has thoroughly sealed the surface.

F. Concrete:

1. Cracks, gaps, hollow areas, bug holes, honey combs, voids, fins, form marks and other protrusions or rough edges are to be ground or stoned to provide a smooth continuous surface.
2. Imperfections may require filling.
 - a. Patch concrete areas with cracks, gaps, hollow areas or other imperfections with compatible material to provide smooth continuous surface.
 - b. Material shall be compatible with and as recommended by the coating manufacturer.
3. Moisture Content:
 - a. Prepared surfaces shall not be painted until they have completely cured and have stabilized moisture content within limits required by the coating manufacturer.
 - b. Testing for Moisture Vapor Emission Rate (MVER) shall be performed to verify suitability using a moisture meter, Delmhorst or equal, or method described in ASTM D4263.
4. Surface shall be reviewed by Architect after surface preparation is complete and prior to application of primer. Additional patching and/or grinding necessary to provide a visually acceptable surface after application of paint coatings shall be accomplished at no additional cost.

- G. Surfaces that cannot be prepared or painted as specified, or to level required by the coating manufacturer, shall be immediately brought to the attention of the Architect, in writing.
 - 1. Starting of work without such notification will be considered acceptance by the Contractor of surfaces involved.
 - 2. Replace unsatisfactory work caused by improper or defective surfaces, as directed by Architect.

3.3 REPAINTING EXISTING INTERIOR SURFACES

- A. Interior surfaces required to be repainted, except acoustic tile, shall be prepared as follows.
 - 1. Wash clean with solution of trisodium phosphate in water and thoroughly rinse or wash with approved self-neutralizing detergent.
 - 2. Spackle, patch, sandpaper, repair, spot or partially prime to provide "hold out" for finish coats of paint and otherwise properly prepare as necessary to provide suitable surfaces, reasonably equal to new, over which to apply specified paints.

3.4 REPAINTING EXISTING EXTERIOR SURFACES

- A. General:
 - 1. Exterior surfaces required to be re-painted, shall be power washed with surfactant, followed by rinsing to remove all loose coatings, chalk, dirt, efflorescence, oils, and other contaminants that would inhibit bond of new coating.
 - 2. Mold or mildew shall be treated with bleach solution followed by thorough rinsing.
 - 3. Protect openings into interior spaces during power washing including louvers, vents, vent screeds, grilles, to prevent water from entering interior areas including, attics and soffits.

- B. Plaster and Concrete Masonry:
 - 1. Remove loose coatings using hand or power tools.
 - 2. Patch plaster areas where original material has cracked, spalled or otherwise been removed with compatible material. Fill areas completely to provide smooth, even surface for refinishing. Spot prime patches prior to proceeding.
 - 3. Patch masonry joints with cracks or missing material with compatible materials.

- C. Wood Siding and Trim:
 - 1. Remove loose, flaking or peeling coatings by scraping, chipping or sanding. Feather rough edges by sanding.
 - 2. Surfaces that exhibit moderate to heavy chalk deposits shall be thoroughly cleaned to sound substrate by wire brushing, sanding, or power washing.

PAINTING
SECTION 09 9100
21-1504

3. Spot prime bare wood, exposed nail and fastener heads prior to application of specified prime coat.
4. Glossy surfaces shall be dulled by sanding. Crystalline deposits shall be removed by flushing with water from a hose.
5. Mildew, if present, shall be removed by scrubbing with a commercial mildew wash in accordance with manufacturer's directions.

D. Concrete:

1. Existing exposed concrete scheduled to receive new finish shall be pressure washed or scrubbed to completely remove all bond breakers and oils.
2. Remove loose coatings not removed by pressure washing using hand or power tools.
3. Efflorescence to be removed following procedures recommended by the paint manufacturer.
4. Cracks, gaps, hollow areas, bug holes, honey combs, voids, fins, form marks and other protrusions or rough edges are to be ground or stoned to provide a smooth continuous surface.
5. Imperfections may require filling.
 - a. Patch concrete areas with cracks, gaps, hollow areas or other imperfections with compatible material to provide smooth continuous surface.
 - b. Material shall be compatible with and as recommended by paint manufacturer.
6. Test for moisture as specified for new concrete.
7. Surface shall be reviewed by Architect after patching is complete and primer is applied. Additional patching and/or grinding necessary to provide a visually acceptable surface shall be accomplished at no additional cost.

E. Stained Wood Surfaces:

1. Thoroughly sand all surfaces.
2. Fill holes, cracks and defects after first coat with color matched putty.
3. Sand between coats to ensure proper adhesion.

F. Casework to be Refinished: For painted casework, refer to Article 3.2. For lacquer or varnish systems, sand all exposed surfaces and both sides of all doors thoroughly.

G. Exterior Ceramic Tile: Abrade surface to receive paint. Thoroughly power-sand all surfaces to remove smooth and/or glossy finish.

3.5 CAULKING

- A. Caulk all cracks in finished surfaces.
- B. Seal around any wall openings where original sealant is not fully sealing.
- C. Provide sealant at material transitions and intersections as required.

3.6 PROTECTION

- A. Hardware, fixture canopies, outlet covers, switch plates and other such items shall be removed or loosened and replaced after completing work as required for painting and finishing. Protect items until reinstalled.
- B. Protect work and work of others during progress against damage. Leave such work clean and whole. Correct damage by cleaning, repairing, replacing or repainting as directed.
- C. Provide necessary drop cloths for protection of work. Cover finished surfaces adjacent to work.

3.7 APPLICATION

- A. General:
 - 1. Do not apply initial coating until moisture content of surface is within limitations recommended by paint manufacturer.
 - 2. Apply coatings in accordance with manufacturer's recommendations and the additional requirements, as applicable, of the Architectural Painting Manual Guide Specifications for application methods and paint systems.
 - 3. Flow coat on evenly and well brushed in. Should dead spots occur, touch-up before next coat is applied. Should spots or cracks burn through after final coat is applied, apply additional coats to entire surface as necessary to remedy defects.
 - 4. Rate of application shall be within limits recommended by paint manufacturer for surface involved.
- B. Thicknesses: Rate of application shall be within limits recommended by paint manufacturer for surface involved and comply with the following.
 - 1. Paint materials shall be applied in manner to average 1.5 to 3 Dry Mills in thickness for the total number of coats scheduled.
 - 2. Provide Tooke Dry Mill Coating Inspection Gauge manufactured by Micro Metrics Company to the Project Inspector for inspection of finished coating systems if requested.
- C. Refinish whole area where portion of finish is not acceptable.
- D. Adjust natural finishes as necessary to obtain identical appearance on veneers and solid stock.
- E. Equipment adjacent to walls shall be disconnected, using workers skilled in appropriate trades, and moved to permit wall surfaces to be painted. Following completion of painting, they shall be expertly replaced and reconnected.
- F. Top and bottom edges of all doors shall receive same paint system finish required for door faces.
- G. Do not paint over fire-rating labels, fusible links, or sprinkler heads.

PAINTING
SECTION 09 9100
21-1504

3.8 DEFECTIVE WORK

- A. Painter shall be responsible for damage or unsuitable work, including that caused by improperly prepared surfaces. Refinishing shall be at no cost to the Owner. Repair work damaged during construction; touch-up or refinish as necessary any abraded, stained or otherwise damaged surfaces.

3.9 CLEANING AND PROTECTION

- A. Thoroughly clean any drips, splatters, spills, splashes, etc., from walls, floor or other surfaces, with no damage to those surfaces.
- B. Protect work and materials of this Section prior to and during installation, and protect the installed work and materials of other trades.
- C. In the event of damage, make all repairs and replacements necessary to the approval of the Architect at no additional cost to the Owner.

3.10 PAINT SYSTEMS

- A. General:
 - 1. Only major areas are scheduled, but miscellaneous and similar items and areas within room or space shall be treated with suitable system.
 - 2. This Specification shall serve as guide and is meant to establish procedure and quality. Confer with the Architect to determine exact finish desired.
 - 3. Number of coats scheduled is minimum. Additional coats shall be applied at no additional cost as required to hide base material completely, produce uniform color, and provide required and satisfactory finish.
- B. Gloss and Sheen Ratings: Paint gloss shall be defined as the sheen rating of applied paint, in accordance with the following limits in conformance with Master Painters Institute, Inc. (MPI) Standards according to ASTM D523. Not all of the Gloss Levels are necessarily scheduled or used on this Project.

Gloss Level	Description	Units @ 60 degrees	Units @ 85 degrees
G1	Matte or Flat finish	0 to 5	10 max.
G2	Velvet finish	0 to 10	10 to 35
G3	Eggshell finish	10 to 25	10 to 35
G4	Satin finish	20 to 35	35 min.
G5	Semi-Gloss finish	35 to 70	
G6	Gloss finish	70 to 85	
G7	High-Gloss finish	> 85	

- C. Clarification of System Terminology:
 - 1. Interior paint Systems are specified and identified herein by initial letters "INT."
 - 2. Exterior paint Systems are specified and identified herein by initial letters "EXT."

3. The numbers following "INT" and "EXT" for each System identifies the substrate to be coated.
4. Initial numbers for each System identify the substrate to be coated summarized as follows with further clarification included with the System description:

CODE	DESCRIPTION
3.1	Concrete
3.2	Cement Plaster
4	Masonry
5	Metal
6	Wood
9.2	Gypsum Board
9.3	Acoustical Panels and Tile

5. The letter following substrate number identifies the general finish coat chemistry summarized as follows:

CODE	DESCRIPTION
A	Standard acrylic
B	Non-bridging vinyl acrylic
C	Epoxy-like acrylic
D	Semi-transparent stain
E	Elastomeric
F	High performance epoxy-like acrylic
G	Lacquer
H	Aliphatic urethane
I	Fire Retardant Intumescent
J	Acrylic Urethane
K	PVA primer
L	Acrylic primer
M	Premium performance acrylic polymer

6. Hyphenated suffix identifies the topcoat gloss level.

3.11 INTERIOR PAINTING SYSTEMS

INT 3.1A-3

Acrylic on Concrete - Gloss Level 3

1 coat	971 AcryPlex	Vinyl Acrylic Primer (if not previously painted)
2 coats	1010 Premium Professional	Latex Eggshell

INT 3.2A-3

Acrylic on Interior Cement Plaster- Gloss Level 3

1 coat	971 AcryPlex	Vinyl Acrylic Primer (if not previously painted)
2 coats	1010 Premium Professional	Latex Eggshell

3.12 EXTERIOR PAINTING SYSTEMS

EXT 3.1A-2

Acrylic on Concrete - Gloss Level 2

1 coat	247 AcryShield	Acrylic Masonry Primer
2 coats	1210 Premium Professional	100% Acrylic Low Sheen

EXT 3.2A-2

Acrylic on Cement Plaster - Gloss Level 2

1 coat	6001-XXXX	Acrylic Bonding Primer
2 coats	1210 Premium Professional	100% Acrylic Low Sheen

EXT 4.1A-2

Acrylic on Concrete Unit Masonry - Gloss Level 2

1 coat	247 AcryShield	Acrylic Masonry Primer
2 coats	1210 Premium Professional	100% Acrylic Low Sheen

EXT 5.1A-5

Acrylic over Unprimed Steel - Gloss Level 5

1 coat	5725 DTM	Metal Primer
2 coats	1215 Premium Professional	100% Acrylic Semi-Gloss

EXT 5.2A-6

Acrylic Urethane over Epoxy on Shop Primed Steel – Gloss Level 6

1 coat	Rust-Oleum “ROC Prime”	Single component waterborne epoxy primer
1 coat	Rust-Oleum “Metalmax Plus DTM”	Single Component Acrylic Urethane Gloss

Note: Provide additional topcoat if required to achieve manufacturer’s recommended total DFT (primer plus finish coats), or to achieve complete hiding for selected color.

EXT 5.3A-5

Premium Acrylic over Waterborne Primer on Galvanized Metal – Gloss Level 5

Pretreatment	SSPC SP-1	Heavy-duty cleaner
1 coat	5725 DTM	Acrylic Primer
2 coats	1250 AcryShield”	100% Acrylic Semi-Gloss

Note: Provide pretreatment and primer if preparation and primer not applied in shop

EXT 5.4A-5

Acrylic over Waterborne Primer on Aluminum – Gloss Level 5

Pretreatment	Devco Devprep 88	Heavy-duty cleaner
1 coat	“5725 DTM	Acrylic Primer
2 coats	1215 Premium Professional	100% Acrylic Semi-Gloss

Note: Provide pretreatment and primer if preparation and primer not applied in shop

PAINTING
SECTION 09 9100
21-1504

3.13 MISCELLANEOUS PAINTING

- A. Mechanical and Electrical Equipment, Conduits and Piping: Paint exposed items as scheduled using appropriate system for material and whether or not item has been factory-primed.
- B. Exposed Insulation-Covered Piping: Size with Arabol, or equal latex type adhesive, and apply 2 coats of semi-gloss enamel.
- C. Material Visible through Grilles, Screens, Louvers, Vents and Screens and Exposed Hardware Cloth Screening: Painted flat black to make them as unnoticeable as possible.
- D. Mechanical Equipment: Paint mechanical equipment housings where indicated on the Drawings.

END OF SECTION

i:\1504 scusd shade structures multiple sites\5.02 addenda\09 9100_painting.docx
Last Updated: September 15, 2021

ESCUTCHEON COVER, TYP.

3" DIA. WALL MOUNT FLANGE, TYP.
ATTACH TO WALL:
- AT BRICK O/ CONCRETE WALL:
(3) 1/4" DIA. S.S. HILTI KB-TZ2 WEDGE
ANCHORS W/ 3" MIN. EMBEDMENT
INTO CONCRETE

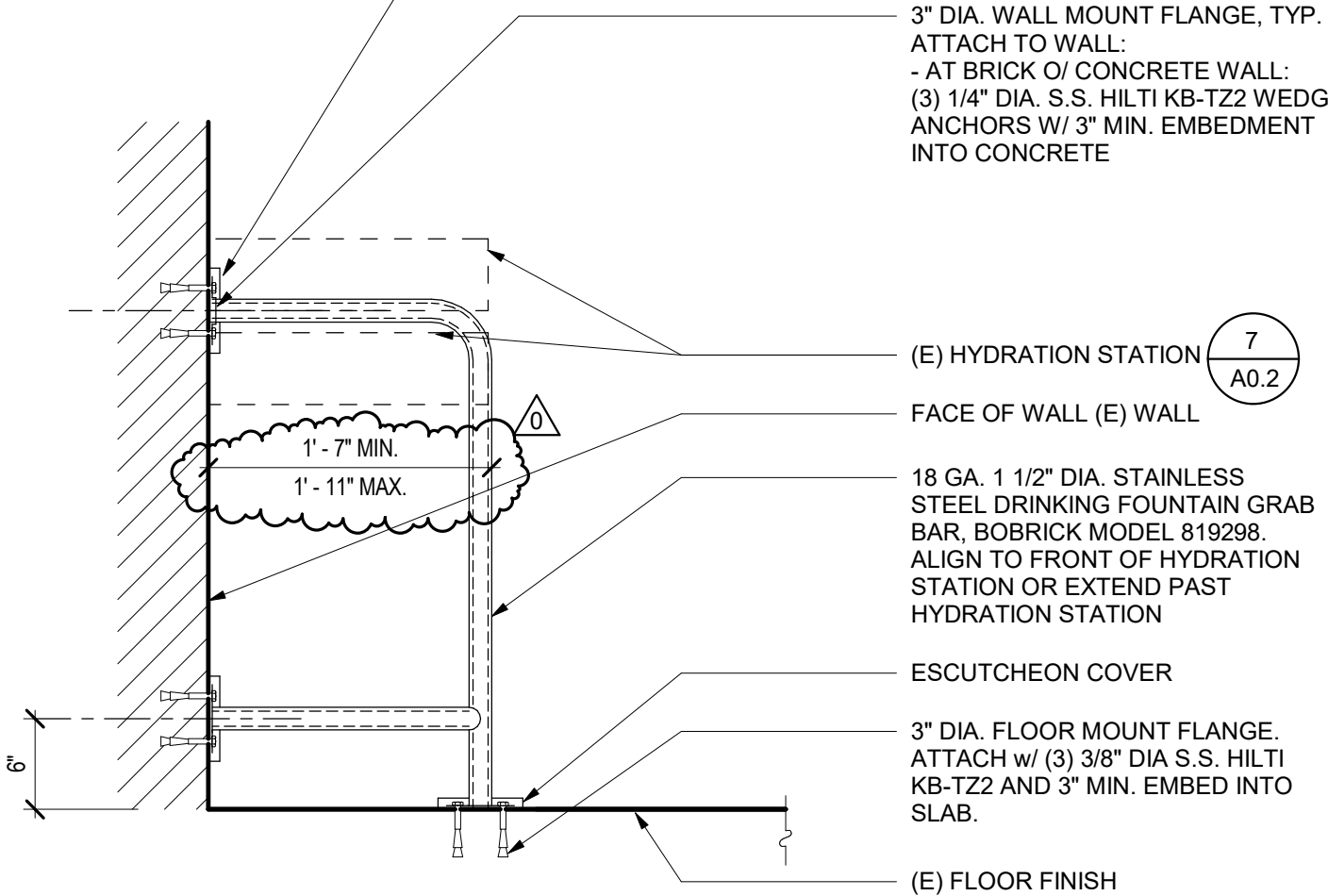

(E) HYDRATION STATION 7
A0.2

FACE OF WALL (E) WALL

18 GA. 1 1/2" DIA. STAINLESS
STEEL DRINKING FOUNTAIN GRAB
BAR, BOBRICK MODEL 819298.
ALIGN TO FRONT OF HYDRATION
STATION OR EXTEND PAST
HYDRATION STATION

ESCUTCHEON COVER

3" DIA. FLOOR MOUNT FLANGE.
ATTACH W/ (3) 3/8" DIA S.S. HILTI
KB-TZ2 AND 3" MIN. EMBED INTO
SLAB.

(E) FLOOR FINISH

8

HYDRATION STATION GUARDRAIL

1" = 1'-0"

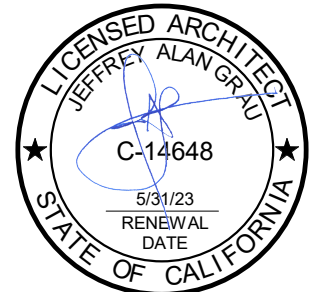

ALL FEATURES, NOTES AND DIMENSIONS NOT SPECIFICALLY SHOWN OR NOTED
AS CHANGED SHALL REMAIN AS SHOWN ON PREVIOUSLY ISSUED DOCUMENTS.

ADDENDUM 0



HYDRATION STATION

A0.2

DATE: 04/29/22

SHADE STRUCTURE AT JOHN D. SLOAT
ELEMENTARY SCHOOL
SACRAMENTO CITY UNIFIED SCHOOL DISTRICT
SACRAMENTO, CA
DSA APP.02-119974

PROJECT NO.: 21-1504.06

SHEET:

AD0.01

EXISTING TOPOGRAPHY

- = PROPERTY LINE
- = CENTERLINE
- = EASEMENT
- ⊙ = PROPERTY CORNER FOUND AS NOTED
- ⊙ = PROPERTY CORNER NOTHING FOUND OR SET
- △123 = TEMPORARY BENCHMARK (SEE TBM LIST FOR INFO)
- = SWALE OR DRAINAGE FLOW
- = DRAINAGE FLOW
- = FENCE (TYPE NOTED)
- = TREE (SIZE/TYPE INDICATED)
- = SLOPE
- 100 = CONTOUR
- = CONCRETE SURFACE
- = EDGE OF ASPHALT
- = EDGE OF BUILDING
- = SIGN
- = POST OR BOLLARD
- 99.99 = GROUND ELEVATION
- 99.99 = HARD SURFACE ELEVATION

EXISTING UTILITIES

- 12"SD = STORM DRAIN LINE (SIZE & DIRECTION OF FLOW)
- 12"SD = STORM DRAIN LINE (RECORD INFORMATION)
- 12"SD = STORM DRAIN LINE (UNDERGROUND LOCATING)
- ⊙ = STORM DRAIN MANHOLE
- = STORM DRAIN CLEANOUT
- = DROP INLET
- = AREA DRAIN
- = RAIN WATER LEADER
- DS = DOWNSPOUT
- 12"SS = SANITARY SEWER LINE (SIZE & DIRECTION OF FLOW)
- 12"SS = SANITARY SEWER LINE (RECORD INFORMATION)
- 12"SS = SANITARY SEWER LINE (UNDERGROUND LOCATING)
- ⊙ = SANITARY SEWER MANHOLE
- = SANITARY SEWER CLEANOUT
- W = WATER LINE (SIZE INDICATED)
- W = WATER LINE (RECORD INFORMATION)
- W = WATER LINE (UNDERGROUND LOCATING)
- ⊙ = WATER MANHOLE
- ⊙ = WATER VALVE
- ⊙ = WATER METER
- ⊙ = WATER BOX
- = IRRIGATION CONTROL VALVE
- = FIRE HYDRANT
- = BACKFLOW PREVENTER
- = SPRINKLER
- = HOSE BIBB
- OH-E = OVERHEAD ELECTRIC LINE
- E = UNDERGROUND ELECTRIC LINE
- E = UNDERGROUND ELECTRIC LINE (RECORD INFORMATION)
- E = UNDERGROUND ELECTRIC LINE (UNDERGROUND LOCATING)
- ⊙ = ELECTRIC MANHOLE
- = UTILITY POLE (WITH GUY WIRE)
- ⊙ = ELECTRIC METER
- ⊙ = ELECTRIC BOX
- ⊙ = STREET LIGHTING BOX
- OR ⊙ = LIGHT STANDARD
- ⊙ = SIGNAL LIGHT
- ⊙ = FLOOD LIGHT
- = ELECTRICAL OUTLET
- G = GAS LINE (SIZE INDICATED)
- G = GAS LINE (RECORD INFORMATION)
- G = GAS LINE (UNDERGROUND LOCATING)
- ⊙ = GAS MANHOLE
- ⊙ = GAS VALVE
- ⊙ = GAS METER
- T = TELEPHONE LINE
- T = TELEPHONE LINE (RECORD INFORMATION)
- T = TELEPHONE LINE (UNDERGROUND LOCATING)
- ⊙ = STORM DRAIN BOX
- ⊙ = TRAFFIC SIGNAL BOX

TBM LIST

NUMBER	DESCRIPTION	NORTHING	EASTING	ELEV
1	CPS CHISELED "+"	9983.38	10002.02	15.76
2	CPS CHISELED "+"	10312.70	10047.77	16.41
3	CPS PK+WASHER	10185.01	10202.41	16.37
4	CPS CHISELED "+"	9921.93	9880.18	15.33
5	CPS CHISELED "+"	10025.15	9638.88	16.13
6	CPS CHISELED "+"	10150.20	9913.92	16.57
7	CPS CHISELED "+"	10189.90	9875.98	16.63
8	CPS CHISELED "+"	10280.42	9876.46	16.65
9	CPS CHISELED "+"	10262.68	9692.14	16.58
10	CPS CHISELED "+"	10351.57	9833.57	18.85
11	CPF CL MON SAC CITY	10543.07	9936.25	15.84
12	CPF CHISELED "+"	10522.85	9937.04	15.20

A.P.N.	048-0168-001
BENCHMARK NO.	G2907 ELEV. 15.84
C/L MON AT 69TH AVE. AND CARELLA DR., CITY OF SACRAMENTO DATUM, GPS POINT ID G2907	

CIVIL ABBREVIATIONS AND LEGEND

ABBREVIATIONS

- NOTE: NOT ALL ABBREVIATIONS MAY BE USED ON THESE PLANS.
- AB AGGREGATE BASE
 - AC ASPHALTIC CONCRETE
 - AD AREA DRAIN
 - APN ASSESSOR'S PARCEL NUMBER
 - ARV AIR RELEASE VALVE
 - ASB AGGREGATE SUB-BASE
 - BO BLOW-OFF VALVE
 - BV BUTTERFLY VALVE
 - BW BACK OF WALK
 - C/L CENTERLINE
 - CB CATCH BASIN
 - CL CLASS
 - CMP CORRUGATED METAL PIPE
 - CATV CABLE TELEVISION
 - CO CLEANOUT
 - COMM COMMUNICATION
 - CONC. CONCRETE
 - CONSTR. CONSTRUCTION
 - CR CURB RETURN
 - CS CONCRETE SURFACE
 - DC DOUBLE CHECK VALVE
 - DDC DOUBLE DETECTOR CHECK VALVE
 - DG DECOMPOSED GRANITE
 - DI DROP INLET
 - DIA DIAMETER
 - DIP DUCTILE IRON PIPE
 - DWG DRAWING
 - DS DOWNSPOUT
 - EP ELECTRIC
 - EP EASEMENT
 - ESMT EXISTING
 - EX FIRE SERVICE LINE
 - FL FLOWLINE
 - FM SANITARY SEWER FORCE MAIN
 - FF FINISHED FLOOR ELEVATION
 - GH FIRE HYDRANT
 - G GRATE ELEVATION
 - GRD GRADE ELEVATION
 - GV GATE VALVE
 - HB HOSE BIBB
 - HBD HEADER BOARD
 - HDPE HIGH DENSITY POLYETHYLENE PIPE
 - HP HIGH POINT
 - INV PIPE INVERT ELEVATION
 - JP JOINT UTILITY POLE
 - LF LINEAL FEET
 - LIP LIP OF GUTTER
 - LT LEFT
 - MS MOVESTRIP
 - NTS NOT TO SCALE
 - OH OVERHEAD
 - PCC PORTLAND CEMENT CONCRETE
 - PD PLANTER DRAIN
 - PIV POST INDICATOR VALVE
 - P/L PROPERTY LINE
 - PP POWER POLE
 - PUE PUBLIC UTILITY EASEMENT
 - PVC POLYVINYL CHLORIDE
 - PCP REINFORCED CONCRETE PIPE
 - R RADIUS
 - RM MANHOLE RIM ELEVATION (SOLID COVER)
 - RP REDUCED PRESSURE BACKFLOW PREVENTER
 - RW RIGHT OF WAY
 - SCH SCHEDULE
 - SD STORM DRAIN
 - SDMHH STORM DRAIN MANHOLE
 - SG SUBGRADE ELEVATION
 - SS SANITARY SEWER
 - SSMH SANITARY SEWER MANHOLE
 - STD STANDARD
 - S/W SIDEWALK
 - T TELEPHONE
 - TC TOP OF CURB
 - TD TRENCH DRAIN
 - TDCB TRENCH DRAIN CATCH BASIN
 - TP TELEPHONE POLE
 - TR TOP OF RAMP ELEVATION
 - TRW TOP OF RETAINING WALL
 - TSW TOP OF SEAT WALL
 - TW TOP OF WALK ELEVATION
 - U UTILITY
 - UG UNDERGROUND
 - UON UNLESS OTHERWISE NOTED
 - VCP VITRIFIED CLAY PIPE
 - W WATER
 - W/ WITH
 - W/O WITHOUT
 - WV WATER VALVE

LEGEND

NOTE: NOT ALL SYMBOLS MAY BE USED ON THESE PLANS.

PROPOSED GRADING & DRAINAGE SYMBOLS:

- 8" SD STORM DRAIN LINE (SIZE AND FLOW SHOWN)
- STORM DRAIN MANHOLE (SDMH)
- CATCH BASIN (CB)
- DROP INLET (DI)
- AREA DRAIN (AD)
- PLANTER DRAIN (PD) OR FLOOR DRAIN (FD)
- STORM DRAIN CLEANOUT
- 99.99 ELEVATION
- FF=100.00 FINISHED FLOOR ELEVATION
- PAD=99.33 BUILDING PAD ELEVATION
- CONCRETE SIDEWALK
- GRADED DIRECTION FOR DRAINAGE FLOW
- SWALE
- SLOPE
- ⊗ TREE TO BE REMOVED
- RETAINING WALL

PROPOSED SANITARY SEWER SYMBOLS:

- 6" SS SANITARY SEWER LINE (SIZE AND FLOW SHOWN)
- SANITARY SEWER MANHOLE (SSMH)
- SEWER CLEANOUT FLUSHER BRANCH

PROPOSED WATER SYMBOLS:

- 8" W WATER LINE & SIZE
- 8" FS FIRE LINE & SIZE
- 8" DW DOMESTIC WATER LINE & SIZE
- 8" RW RECLAIMED WATER LINE & SIZE
- 8" IRR IRRIGATION SERVICE LINE & SIZE
- 8" NP NON POTABLE WATER LINE & SIZE
- 8" SP FIRE SPRINKLER SERVICE LINE & SIZE
- GATE VALVE
- WATER METER
- FIRE HYDRANT ASSEMBLY
- Y FDC FIRE DEPARTMENT CONNECTION
- DC DETECTOR CHECK VALVE
- DDC DOUBLE DETECTOR CHECK VALVE
- RP REDUCED PRESSURE BACKFLOW PREVENTER
- BUTTERFLY VALVE
- 1" AIR RELEASE VALVE + SIZE
- 1" BLOW-OFF VALVE + SIZE
- POST INDICATOR VALVE

DEMOLITION GENERAL NOTES

- IN THE EVENT THAT ANY UNUSUAL CONDITIONS NOT COVERED BY THE GEOTECHNICAL INVESTIGATION REPORT OR ARE ENCOUNTERED DURING GRADING OPERATIONS THE GEOTECHNICAL ENGINEER AND THE ARCHITECT SHALL BE IMMEDIATELY NOTIFIED FOR DIRECTIONS.
- NO BURNING OR BLASTING SHALL BE PERMITTED.
- ADDITIONAL DEMOLITION INFORMATION MAY BE SHOWN ON THE GRADING, DRAINAGE, AND UTILITY PLANS, AND THOSE PLANS PREPARED BY OTHER DISCIPLINES FOR THIS PROJECT.
- ALL DEMOLISHED ITEMS SHALL BE DISPOSED OF OFFSITE AT A SUITABLE, LEGAL, DUMP SITE OR OTHER FACILITY.
- ALL DISPOSED OF MATERIALS SHALL BE RECYCLED IF POSSIBLE.
- THE TYPES, LOCATIONS, SIZES AND/OR DEPTHS OF EXISTING UNDERGROUND UTILITIES AS SHOWN IN THESE PLANS WERE OBTAINED FROM SOURCES OF VARYING RELIABILITY. THE CONTRACTOR IS CAUTIONED THAT ONLY ACTUAL EXCAVATION WILL REVEAL THE TYPES, EXTENT, SIZES, LOCATIONS, AND DEPTHS OF SUCH UNDERGROUND UTILITIES. A REASONABLE EFFORT HAS BEEN MADE TO LOCATE AND DELINEATE ALL KNOWN UNDERGROUND UTILITIES. HOWEVER, WARREN CONSULTING ENGINEERS CAN ASSUME NO RESPONSIBILITY FOR THE COMPLETENESS OR ACCURACY OF ITS DELINEATION OF SUCH UNDERGROUND UTILITIES, NOR FOR THE EXISTENCE OF OTHER BURIED OBJECTS OR UTILITIES WHICH MAY BE ENCOUNTERED BUT WHICH ARE NOT SHOWN ON THESE DRAWINGS. THE CONTRACTOR OR ANY SUBCONTRACTOR FOR THIS CONTRACT SHALL NOTIFY MEMBERS OF UNDERGROUND SERVICE ALERT (USA) TWO (2) WORKING DAYS IN ADVANCE OF PERFORMING ANY EXCAVATION WORK BY CALLING TOLL FREE 1-800-227-2600, OR 811.
- THE SCHOOL DISTRICT SHALL HAVE SALVAGE RIGHTS TO ANY DEMOLISHED ITEMS SHOWN HEREON. THE CONTRACTOR SHALL GIVE THE DISTRICT NOTICE 7 DAYS PRIOR TO THE START OF DEMOLITION. THE DISTRICT SHALL MOVE ANY RETAINED ITEMS OUT OF THE CONTRACTORS WORK AREA, UNLESS ANOTHER ARRANGEMENT IS MADE WITH THE CONTRACTOR. ANY REMAINING ITEMS BECOME THE PROPERTY OF THE CONTRACTOR AND SHALL BE REMOVED FROM THE SITE. ANY ITEMS NOT SHOWN FOR REMOVAL SHALL REMAIN AND SHALL BE PROTECTED FROM DAMAGE DURING CONSTRUCTION TO A REASONABLE EXTENT.
- EXISTING UTILITY STRUCTURES IN AREAS OF NEW PAVING SHALL BE REMOVED AND REPLACED WITH NEW BOX/COVER AT NEW GRADE UNLESS SPECIFICALLY NOTED OTHERWISE.
- ITEMS OUTSIDE THE LIMITS OF DEMOLITION SHALL REMAIN AND BE PROTECTED FROM DAMAGE DURING CONSTRUCTION.
- EXISTING UTILITY STRUCTURES AND PIPING NOT SHOWN ON DEMOLITION PLAN TO BE REMOVED SHALL REMAIN AND BE PROTECTED.

UTILITY VERIFICATION NOTE

PRIOR TO THE START OF CONSTRUCTION, VERIFY AND POTHOLE ALL UTILITY POINTS OF CONNECTION FOR LOCATION, DEPTH, AND SIZE. IF CONFLICT IS FOUND, CONTACT THE ENGINEER IMMEDIATELY FOR DIRECTION.

IRRIGATION DEMOLITION NOTE

WITHIN LANDSCAPE AREAS TO BE DEMOLISHED THERE MAY BE EXISTING IRRIGATION LINES NOT SHOWN ON THIS PLAN. CONTRACTOR SHALL REMOVE LATERAL LINES AND HEADS ENCOUNTERED. MAIN LINES AND CONTROL WIRES MAY ONLY BE REMOVED PROVIDED THAT ROUTING IS KNOWN AND REMOVAL WILL NOT DEACTIVATE AN IRRIGATION SYSTEMS INTENDED TO REMAIN. IF CONFLICT IS FOUND, CONTACT THE ENGINEER FOR DIRECTION.

GENERAL NOTES

- THE TYPES, LOCATIONS, SIZES, AND/OR DEPTHS OF EXISTING UNDERGROUND UTILITIES AS SHOWN ON THESE PLANS WERE OBTAINED FROM SOURCES OF VARYING RELIABILITY. THE CONTRACTOR IS CAUTIONED THAT ONLY ACTUAL EXCAVATION WILL REVEAL THE TYPES, EXTENT, SIZES, LOCATIONS AND DEPTHS OF SUCH UNDERGROUND UTILITIES. A REASONABLE EFFORT HAS BEEN MADE TO LOCATE AND DELINEATE ALL KNOWN UNDERGROUND UTILITIES. HOWEVER, WARREN CONSULTING ENGINEERS CAN ASSUME NO RESPONSIBILITY FOR THE COMPLETENESS OR ACCURACY OF ITS DELINEATION OF SUCH UNDERGROUND UTILITIES, NOR FOR THE EXISTENCE OF OTHER BURIED OBJECTS OR UTILITIES WHICH MAY BE ENCOUNTERED BUT WHICH ARE NOT SHOWN ON THESE PLANS. THE CONTRACTOR OR ANY SUBCONTRACTOR FOR THIS CONTRACT SHALL NOTIFY MEMBERS OF UNDERGROUND SERVICE ALERT (USA) TWO (2) WORKING DAYS IN ADVANCE OF PERFORMING ANY EXCAVATION WORK BY CALLING TOLL FREE 1-800-227-2600, OR 811.
- WARREN CONSULTING ENGINEERS, INC. (WCE) ASSUMES NO RESPONSIBILITY FOR ERRORS IN PHYSICAL LOCATION OF IMPROVEMENTS, HORIZONTAL OR VERTICAL, MADE BY OTHERS. IN ADDITION, ANY SUCH ERRORS IN PHYSICAL LOCATION MAY AFFECT THE INTENDED DESIGN OF SUCH IMPROVEMENTS AND WCE CANNOT BE HELD RESPONSIBLE FOR SUCH CONDITIONS WHICH ARE A RESULT OF ERRORS IN SURVEYING, OR IMPROPER CONSTRUCTION.
- IF SUBSURFACE CULTURAL RESOURCES, REMAINS, AND/OR ARTIFACTS ARE UNCOVERED DURING PROJECT CONSTRUCTION, ALL WORK IN THE VICINITY SHALL BE STOPPED UNTIL SUCH ITEMS CAN BE ASSESSED BY AN APPROPRIATE MEMBER OF THE COUNTY ENVIRONMENTAL IMPACT SECTION STAFF.
- CONTRACTOR AGREES THAT HE/SHE SHALL ASSUME SOLE AND COMPLETE RESPONSIBILITY FOR JOB SITE CONDITIONS DURING THE COURSE OF CONSTRUCTION OF THIS PROJECT, INCLUDING SAFETY OF ALL PERSONS AND PROPERTY; THAT THIS REQUIREMENT SHALL APPLY CONTINUOUSLY AND SHALL NOT BE LIMITED TO NORMAL WORKING HOURS; AND THAT THE CONTRACTOR SHALL DEFEND, INDEMNIFY AND HOLD THE OWNER AND ENGINEER HARMLESS FROM ANY AND ALL LIABILITY, REAL OR ALLEGED, IN CONNECTION WITH THE PERFORMANCE OF WORK ON THIS PROJECT, EXCEPTING FOR LIABILITY ARISING FROM THE SOLE NEGLIGENCE OF THE OWNER OR ENGINEER.
- THE CONTRACTOR SHALL OBTAIN AN EXCAVATION PERMIT FROM THE STATE OF CALIFORNIA DEPARTMENT OF INDUSTRIAL SAFETY FOR ALL EXCAVATIONS OF 5 FEET OR MORE IN DEPTH.
- IT SHALL BE THE CONTRACTOR'S RESPONSIBILITY TO MAKE ALL NECESSARY PRE-BID AND PRE-CONSTRUCTION SITE INSPECTION, AND/OR OBSERVATIONS ON THE SITE TO PRE-DETERMINE ALL HIS/HER MEANS AND METHODS NECESSARY TO COMPLETE THE IMPROVEMENTS SHOWN ON THESE PLANS AND PER THE PROJECT SPECIFICATIONS. IT IS THE CONTRACTOR'S RESPONSIBILITY TO DETERMINE, AND INCLUDE IN HIS/HER CONTRACT, ALL MEANS AND METHODS NECESSARY TO PERFORM A COMPLETE AND ACCEPTABLE JOB.
- WHERE IMPROVEMENTS LIE WITHIN AN EXISTING DEVELOPED AREA, CONTRACTOR SHALL USE CAUTION WHEN ACCESSING THE SITE THROUGH THESE EXISTING IMPROVEMENTS. IT IS THE CONTRACTOR'S RESPONSIBILITY TO PROTECT ANY SUCH EXISTING IMPROVEMENTS OUTSIDE THE PROJECT BOUNDARY, OR EXISTING IMPROVEMENTS WITHIN THE BOUNDARY WHICH ARE TO REMAIN. PROPER PRECAUTIONS SHALL BE PROVIDED AND MAINTAINED THROUGHOUT CONSTRUCTION. ANY DAMAGE SHALL BE REPAIRED OR REPLACED TO THE SATISFACTION OF THE OWNER.
- IT IS THE RESPONSIBILITY OF THE CONTRACTOR TO KEEP DETAILED RECORDS OF MINOR CHANGES OR ADJUSTMENTS MADE DURING CONSTRUCTION (WHICH WERE NOT FORMALLY ISSUED). UPON PROJECT COMPLETION, THESE RECORDS AND/OR INFORMATION SHALL BE PROVIDED TO THE OWNER AND WARREN CONSULTING ENGINEERS, INC. UNLESS AN OFFICIAL "AS-BUILT" SET OF PLANS IS A REQUIREMENT OF THE CONTRACT. IF AS-BUILT PLANS ARE A REQUIREMENT OF THE CONTRACT, REFER TO SPECIFICATIONS FOR AS-BUILT DELIVERABLE REQUIREMENTS.
- IN VEHICULAR PATHWAYS, EXISTING ASPHALTIC AND/OR CONCRETE SURFACES SHALL BE CUT TO A NEAT AND STRAIGHT LINE, PARALLEL OR PERPENDICULAR TO THE VEHICULAR TRAVELED PATH. THIS IS TYPICALLY THE ROADWAY CENTERLINE, BUT MAY VARY. THAT SAWCUT EDGE SHALL BE PROTECTED FROM DAMAGE DURING CONSTRUCTION SO A CLEAR PATCH AREA BEHIND THE EDGE IS DAMAGED. A NEW SAW CUT WILL BE REQUIRED. THE EXPOSED EDGE SHALL BE "TACKED" WITH EMULSION PRIOR TO PAVING.
- NO BURNING OR BLASTING SHALL BE ALLOWED ONSITE UNLESS SPECIFICALLY ADDRESSED ON PLANS, OR SPECIFICALLY APPROVED AND COORDINATED WITH THE ARCHITECT, ENGINEER, AND LOCAL AGENCY OR OTHER ADMINISTRATIVE AUTHORITY.
- SUBGRADE AND RESULTING FINISHED GRADE SHALL BE CONSTRUCTED SMOOTH AND UNIFORM BETWEEN SPOT ELEVATIONS, CONTOURS OR OTHER STRUCTURE ELEVATIONS SHOWN ON GRADING OR OTHER PLANS. NO MOUNDS, RUTS, DEPRESSIONS OR OTHER GRADING DEFICIENCIES WILL BE ALLOWED UNLESS SPECIFICALLY SHOWN ON PLANS.
- ON NEW WATER SYSTEMS, SERVICE LATERALS SHALL BE MADE USING APPROPRIATE "TEE" AND "WYE" FITTINGS. SADDLE TAPS WILL ONLY BE ALLOWED WHEN MAKING CONNECTIONS TO EXISTING WATER MAINS.
- CURING COMPOUND SHALL BE APPLIED IN A CONTINUOUS SOLID WET FLOWING COAT. ANY "SPOTTY" APPLICATIONS SHALL BE RECOATED IMMEDIATELY. APPLICATION SHALL BE INSPECTED BY PROJECT INSPECTOR DURING APPLICATION.
- EMBEDMENT OF FEATURES IN CONCRETE PAVING, CURBS, OR WALLS, SUCH AS SQUARE OR ROUND TUBING, POSTS, OR COLUMNS, STEEL BOLTED PLATES, OR OTHER STRUCTURES, SHALL REQUIRE ADDITIONAL SCORE OR EXPANSION JOINTS TO PREVENT UNCONTROLLED CRACKING. THOSE ADDITIONAL JOINTS MAY OR MAY NOT BE SPECIFICALLY SHOWN ON PLANS BUT SHALL BE PROVIDED BY THE CONTRACTOR.
- EMBEDMENT OF FEATURES IN CONCRETE PAVING, CURBS, OR WALLS, SUCH AS SQUARE OR ROUND TUBING, POSTS, OR COLUMNS, STEEL BOLTED PLATES, SHALL REQUIRE A MINOR ADJUSTMENT OF REBAR WITHIN CONCRETE TO ALLOW FOR SUCH STRUCTURE. THAT REBAR ADJUSTMENT MAY NOT BE SPECIFICALLY SHOWN ON PLANS.
- NO MORE THAN 1 GALLON OF WATER PER YARD OF CONCRETE CAN BE ADDED TO THE TRUCK AFTER ARRIVAL TO PROJECT SITE. THE ADDITION OF WATER CAN ONLY BE ADDED UNDER THE SUPERVISION OF THE CONCRETE INSPECTOR OR LABORATORY TECHNICIAN.
- WHEN PUMPING CONCRETE FOR PLACEMENT, ABSOLUTELY NO WATER IS TO BE ADDED TO PUMP HOPPER. ANY WATER ADDED TO HOPPER WILL BE REASON FOR CONCRETE REJECTION AT THE CONTRACTORS EXPENSE.
- ALL CONTRACTION/CONSTRUCTION JOINTS "CJ" SHALL BE 1/4 THE SLAB THICKNESS DEEP, BUT NO LESS THAN 1" FOR CONTROLLING OF CRACKING. CONTRACTOR SHALL EXERCISE CAUTION WHEN FINAL TROWELING OF CONCRETE SO AS NOT TO FILL IN THESE JOINTS WITH CONCRETE CREAM. ANY CRACKS OUTSIDE OF JOINTS WHICH WERE CONSTRUCTED LESS THAN 1" DEEP, SHALL BE CAUSE FOR CONCRETE SLAB(S) TO BE REMOVED AND REPLACE AT CONTRACTORS EXPENSE.
- ANY SCORED BOARDS SET WITHIN CONCRETE SLABS SHALL BE AN "OVERHEAD SCREED" SO THERE IS NO INTERFERENCE WITH THE PLACEMENT AND ALIGNMENT OF SLAB REINFORCING.
- 3-1/2" FELT JOINTS WILL NOT BE ACCEPTED. PROVIDE A FULL 4" FELT JOINT FOR 4" SLAB CONSTRUCTION, AND A 6" FELT JOINT FOR A 6" SLAB CONSTRUCTION.
- SHOULD ANY SHRINKAGE CRACKS OCCUR OUTSIDE OF EITHER THE EXPANSION JOINTS OR CRACK CONTROL JOINTS, THEN THE CONCRETE SLAB SHALL BE SAWCUT AT THE NEAREST JOINTS ON EACH SIDE OF THE CRACK AND THE CONCRETE SECTION SHALL BE, REMOVED AND REPLACED. NEW CONCRETE SHALL BE DOWELED INTO EXISTING CONCRETE PER DRAWING DETAIL.
- ALL AREAS DISTURBED BY GRADING OPERATIONS WHETHER SHOWN ON THE DRAWINGS OR NOT SHALL BE HYDRO SEEDED UNLESS OTHERWISE NOTED. HYDRO SEEDING SHALL CONFORM TO LOCAL CITY/COUNTY STANDARDS.
- REPAIR OR PATCHING OF GALVANIZED METALS, SUCH AS AFTER WELDING GALVANIZED COMPONENTS, SHALL BE MADE USING A ZINC COMPOSITION "HOT STICK" APPLICATION PER ASTM A 780-01. GALVANIZING PAINTS WILL NOT BE ALLOWED.

GENERAL PAVING SURFACE NOTES:

- PROVIDE EQUIVALENT OF MEDIUM BROOM FINISH AT SLOPES UP TO 5.99%, TYPICAL PROVIDE EQUIVALENT OF HEAVY BROOM FINISH AT SLOPES 6% AND GREATER. REFER TO SPECIFICATIONS.
- ALL NEW PEDESTRIAN WALKWAYS (NON-RAMP) SHALL BE SLOPED NO GREATER THAN 2.0%, AND NO LESS THAN 0.75% IN ANY DIRECTION UNLESS SPECIFICALLY LABELED OTHERWISE. ALL CONCRETE SHALL MEET THE FOLLOWING SLOPE REQUIREMENTS:
 - NO GREATER THAN 5% SLOPE IN THE DIRECTION OF TRAVEL.
 - NO GREATER THAN 2% SLOPE CROSSING THE DIRECTION OF TRAVEL.
 - NO GREATER THAN 2% SLOPE IN ANY DIRECTION IN COURTYARD OR PLAZA AREAS.

CIVIL SHEET INDEX

- C0.1 CIVIL GENERAL NOTES AND ABBREVIATIONS
- C1.1 DEMOLITION PLAN
- C2.1 GRADING AND PAVING PLAN
- C3.1 DETAILS AND SECTIONS

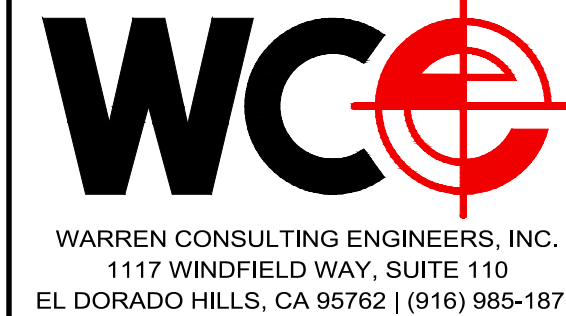
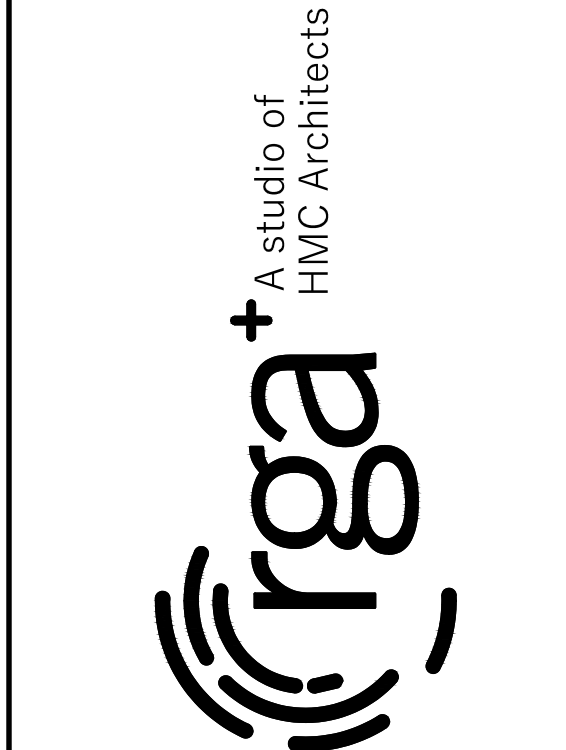

SHADE STRUCTURE AT JOHN D. SLOAT ELEMENTARY SCHOOL
SACRAMENTO CITY UNIFIED SCHOOL DISTRICT
SACRAMENTO, CA

Copyright © 2021 Rainforth Grau Architects. All rights reserved. Reproduction of these plans, either in whole or in part, including any form of copying and/or preparation of derivative works thereof, for any reason without prior written permission, is strictly prohibited.

CIVIL GENERAL NOTES AND ABBREVIATIONS

PROJECT NO. 21-1504.06
DATE: 04/29/22
SHEET **C0.1**

LANDSCAPE/IRRIGATION NOTE:
GENERAL CONTRACTOR IS REQUIRED TO HIRE A LANDSCAPE SUBCONTRACTOR TO PERFORM ALL LANDSCAPE AND IRRIGATION REPAIRS.

C:\Users\mark.luzi\Documents\1504.06 John D Sloat Central mark.luzi.rvt

4/29/2022 8:23:39 AM

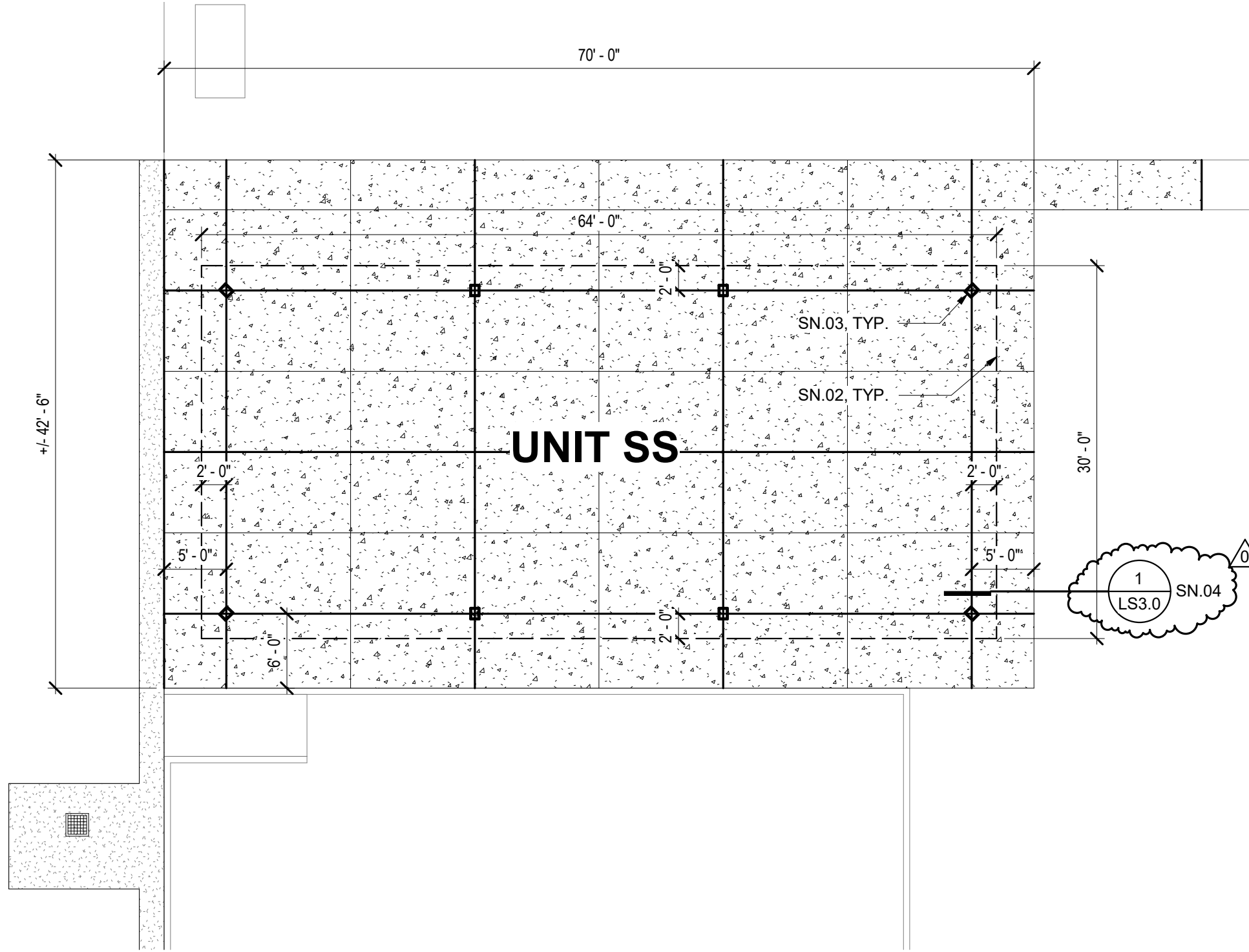

2 ENLARGED SITE PLAN - SHADE STRUCTURE
 1" = 10'-0"

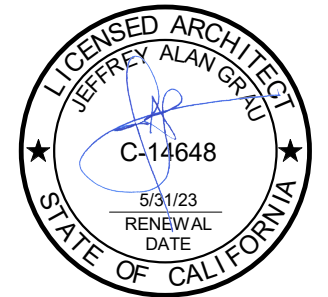

ADDENDUM ⁰

ALL FEATURES, NOTES AND DIMENSIONS NOT SPECIFICALLY SHOWN OR NOTED AS CHANGED SHALL REMAIN AS SHOWN ON PREVIOUSLY ISSUED DOCUMENTS.



ENLARGED PLAN **A1.1.1**
 SHADE STRUCTURE AT JOHN D. SLOAT
 ELEMENTARY SCHOOL
 SACRAMENTO CITY UNIFIED SCHOOL DISTRICT
 SACRAMENTO, CA
 DSA APP.02-119974

DATE: 04/29/22
 PROJECT NO.: 21-1504.06
 SHEET:
AD0.03

CANDLEWOOD WAY

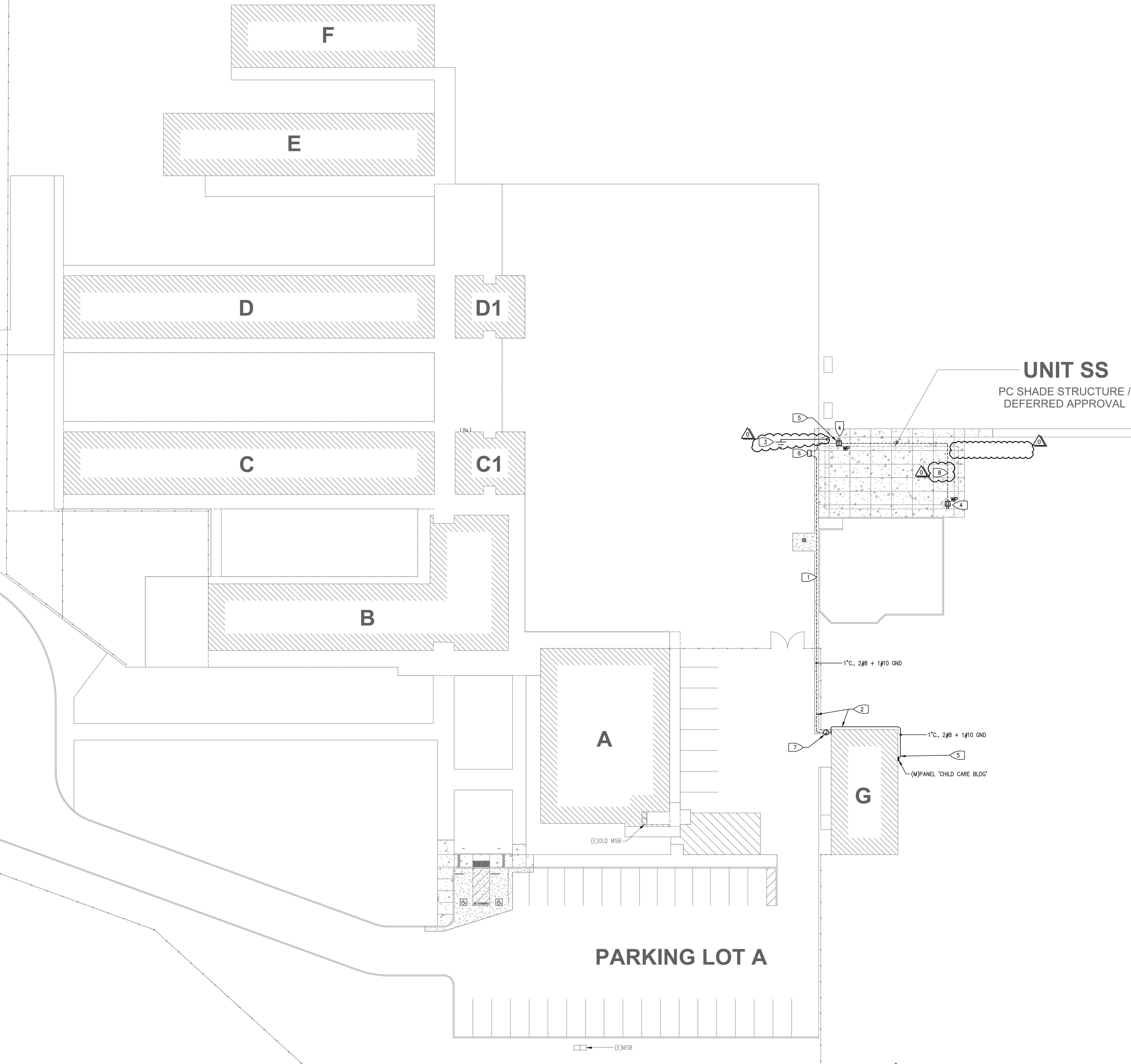

SHEET NOTES:

1. ALL EXISTING EQUIPMENT, DEVICES, CONDUIT AND WIRING, ETC., SHOWN ON PLANS ARE BASED ON AVAILABLE EXISTING DRAWINGS AND LIMITED SITE SURVEYS, AND SHOWN FOR CLARITY ONLY.
2. SEE ONE LINE DIAGRAM AND PANEL SCHEDULE ON SHEET **E2.1** FOR REFERENCE.

KEYED NOTES:

1. PROVIDE TRENCH FOR 24 INCH MINIMUM COVER. LOCATE AND PROTECT (E) UTILITIES, I.E. IRRIGATION, SEWER, DRAINAGE PIPES, ETC. SAW CUT AND PATCH BACK (E) ASPHALT. PROVIDE SAND TO COVER CONDUIT TO SIX(6) INCHES, THEN ADD TRACER TAPE. COMPLETE BACKFILL TO GRADE, COMPACTING IN SIX(6)-INCH LIFTS. FINISH TO MATCH EXISTING. SEE DETAIL **2/E3.1**.
2. RUN CONDUIT HIGH ON WALL TO WRAP AROUND BUILDING, DROP DOWN TO BELOW ASPHALT, AND TRENCH TO SHADE LOCATION, RUNNING CONDUIT TO INTERCEPT THE CHRISTY BOX ALONG THE WAY. PAINT EXPOSED CONDUIT TO MATCH (E) FINISH.
3. PROVIDE AT MINIMUM TWO(2) GROUND RODS, ONE AT THE PULL BOX AND ONE NEAR THE CORNER POST OF THE SHADE STRUCTURE, EACH 5/8" BY TEN(10) FEET LONG, CU, AT LEAST TEN(10) FEET APART. BOND TO METAL OF SHADE STRUCTURE. SEE DETAILS **5/E3.1** AND **2/E3.1**.
4. LOCKABLE, WEATHERPROOF RECEPTACLE TO HAVE A TWO-GANG BACK BOX WITH 1" THREADED PORT(S). MOUNT RECEPTACLES 36" ABOVE GRADE UNLESS SPECIFIED OTHERWISE. SEE DETAIL **4/E3.1**.
5. AT THE PANEL, SPLICE THE #10 CONDUCTORS FROM THE NEW BREAKER TO #8 CONDUCTORS FOR THE RUN TO THE SHADE STRUCTURE. AT THE FIRST SHADE STRUCTURE RECEPTACLE, SPLICE THE #8 CONDUCTORS TO #10 CONDUCTORS AND CONNECT TO DEVICE.
6. PROVIDE CHRISTY B1324 PULL BOX WITHIN FIVE(5) FT OF SHADE STRUCTURE. CHRISTY BOX TO HAVE HOLD DOWN BOLTS AND BE LABELED FOR POWER. SEE DETAIL **2/E3.1**.
7. PROVIDE J-BOX HIGH ON WALL.
8. RUN CONDUIT BELOW SHADE STRUCTURE CONCRETE PAD.

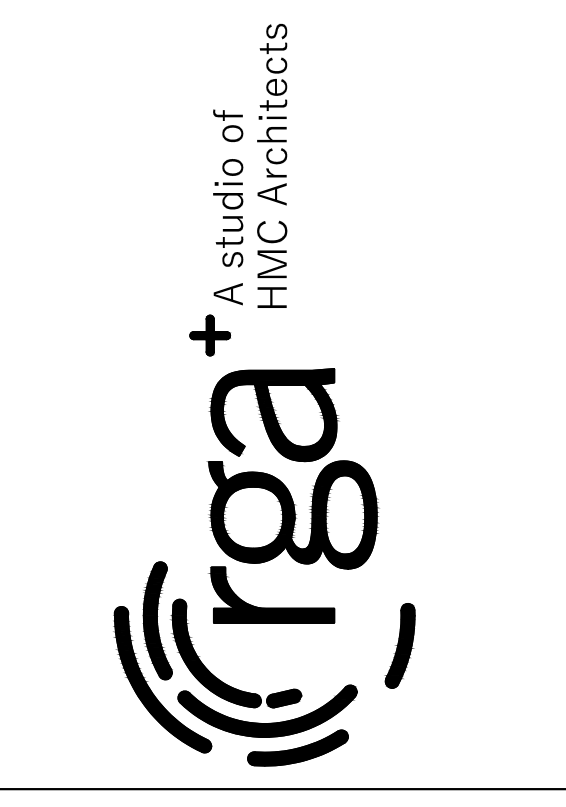

P PETERS engineering
 7750 College Town Dr. ste.101
 Sacramento, CA 95826
 Tel (916) 447-2841
 www.peterseng.com
 Job no. 22.010
 consulting mechanical and electrical engineers



PLOT DATE: 4/26/2022

SHADE STRUCTURE AT JOHN D. SLOAT ELEMENTARY SCHOOL
 SACRAMENTO CITY UNIFIED SCHOOL DISTRICT
 SACRAMENTO, CA

Revision	
ADDENDUM	04/29/22

Copyright © 2021 Rainforth Grau Architects. All rights reserved. Reproduction of these plans, either in whole or in part, including any form of copying and/or preparation of derivative works thereof, for any reason without prior written permission, is strictly prohibited.

SITE PLAN - ELECTRICAL

PROJECT NO. 21-1504.06
 DATE: 04/29/22
 SHEET

E1.1

AD0.04

1 SITE PLAN - ELECTRICAL
 SCALE: 1"=20'

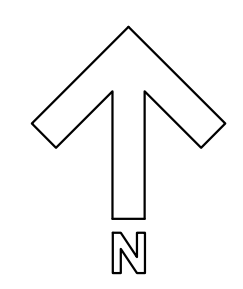

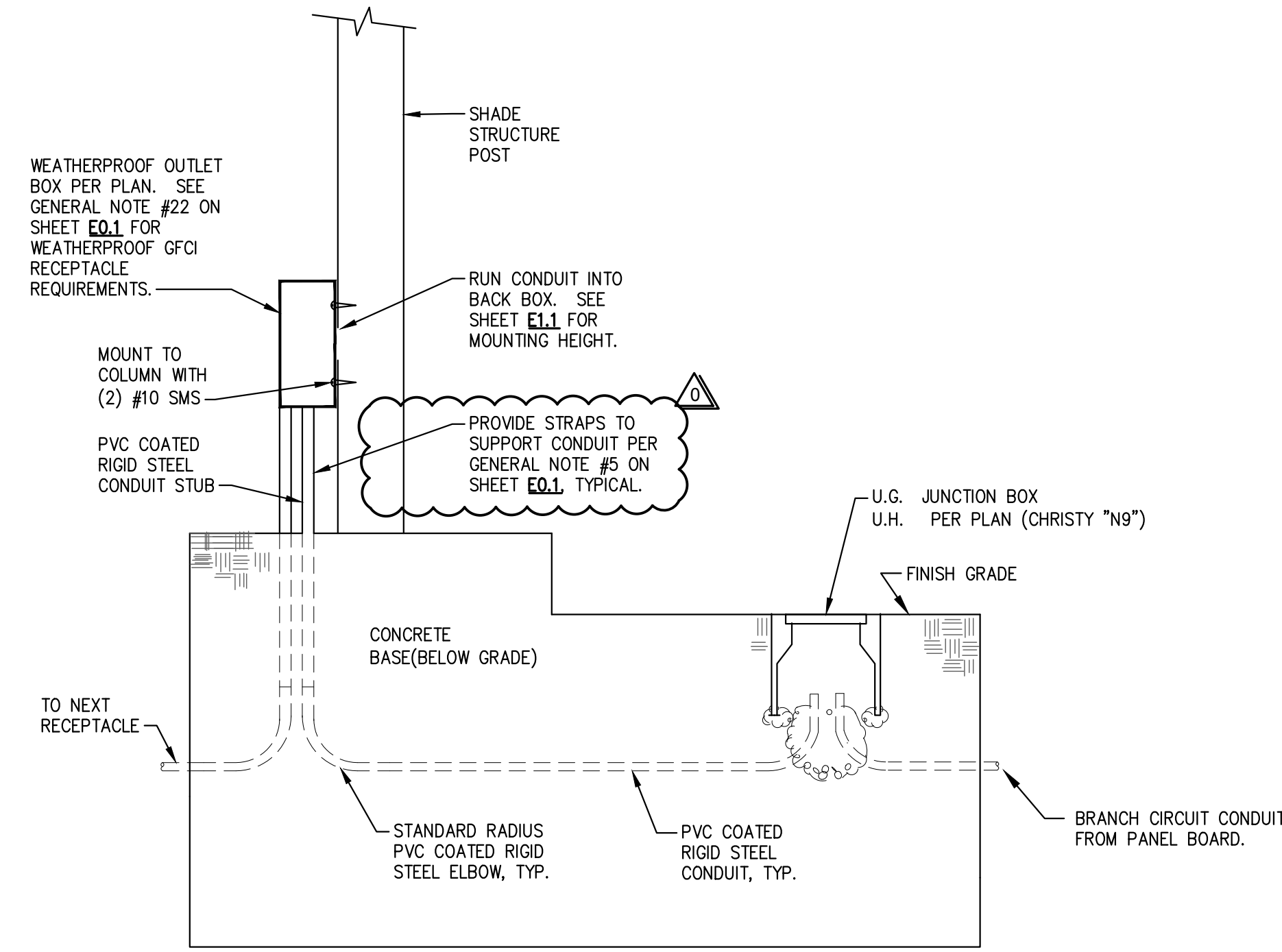
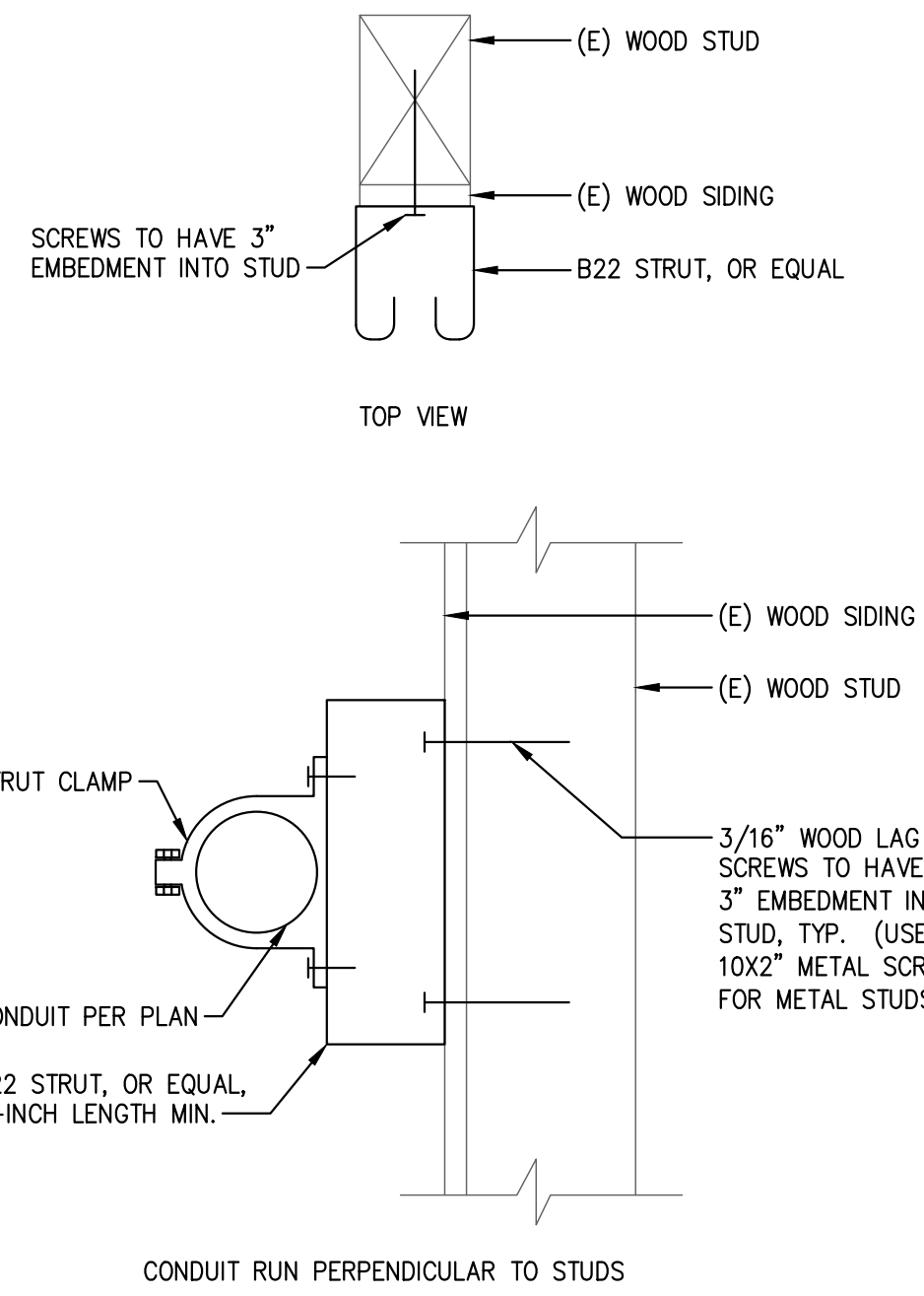
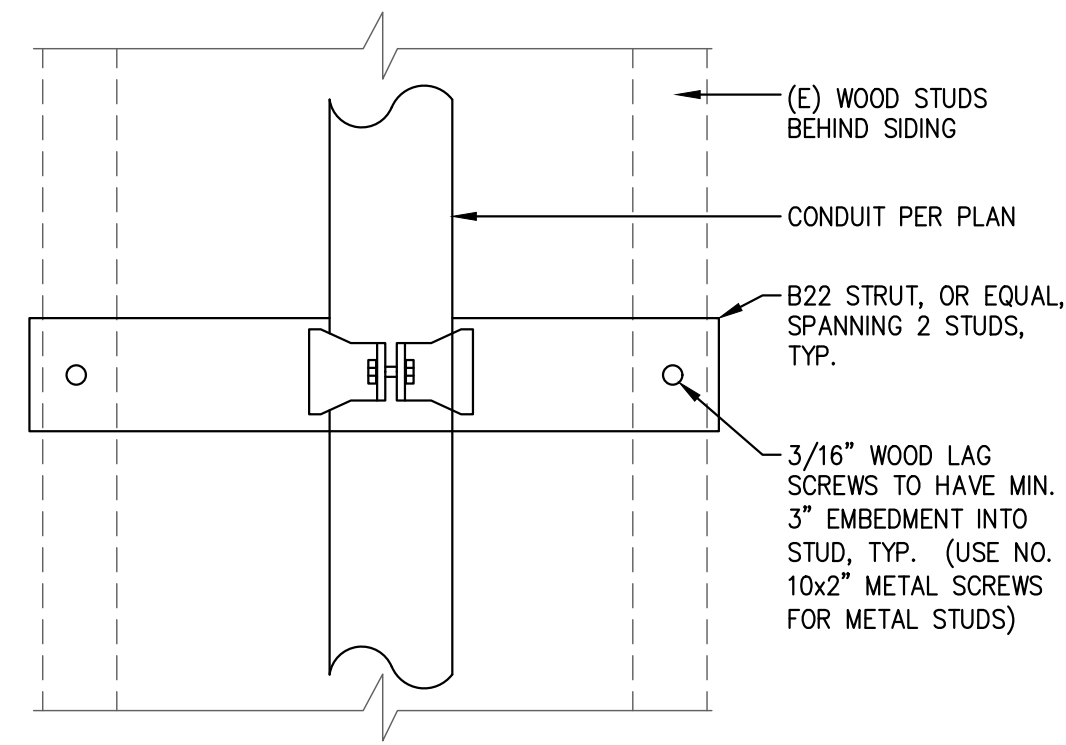

4 CONDUIT STUB IN POST DETAIL
SCALE: NONE

- NOTES:
- CONDUIT SHALL BE SUPPORTED AT INTERVALS NOT EXCEEDING TEN(10) FEET AND NOT MORE THAN THREE(3) FEET FROM THE OUTLET AND AT ANY POINT WHERE IT CHANGES DIRECTION.
 - PERFORATED STRAP AND PLUMBER'S TAPE SHALL NOT BE PERMITTED.
 - MAXIMUM CONDUIT AND CONDUCTOR WEIGHT IS 1.83LBS PER LINEAR FOOT.

7 CONDUIT MOUNTING DETAIL - STUD WALLS
SCALE: NONE

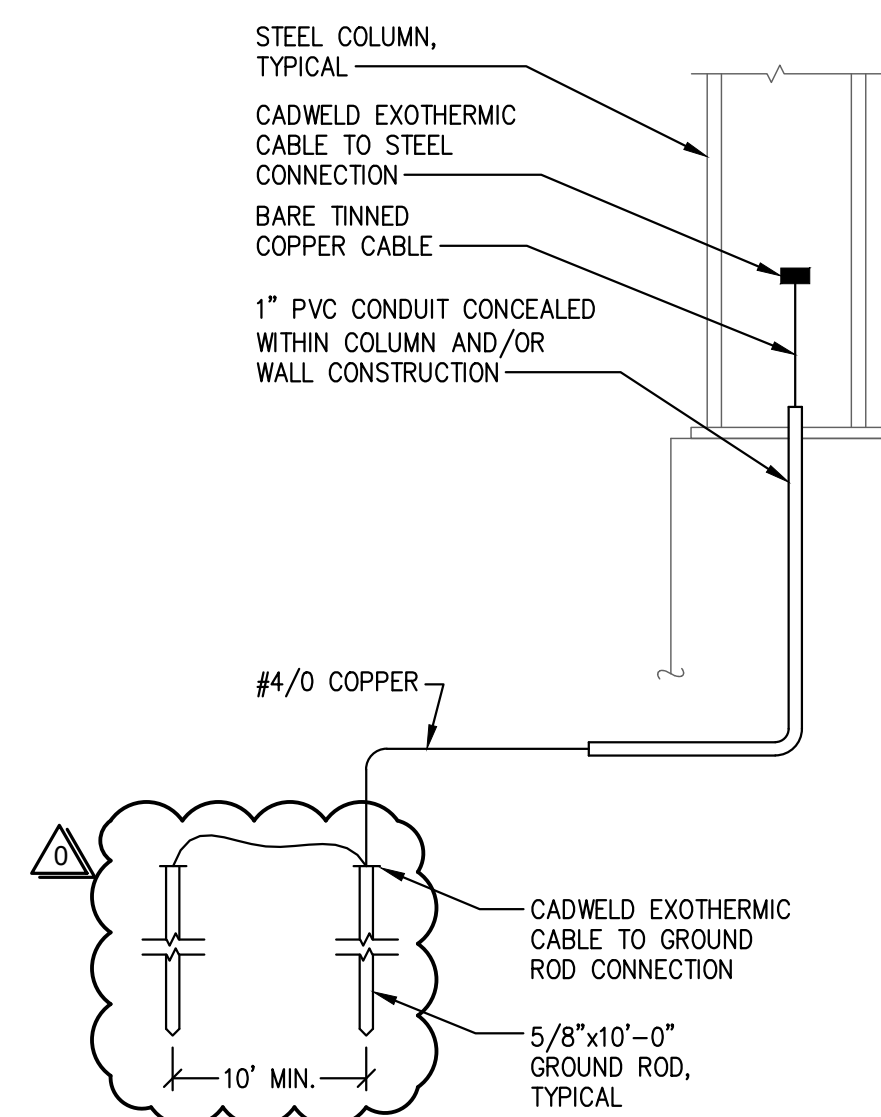

5 TYPICAL STEEL COLUMN & REBAR GROUNDING DETAIL
SCALE: NONE

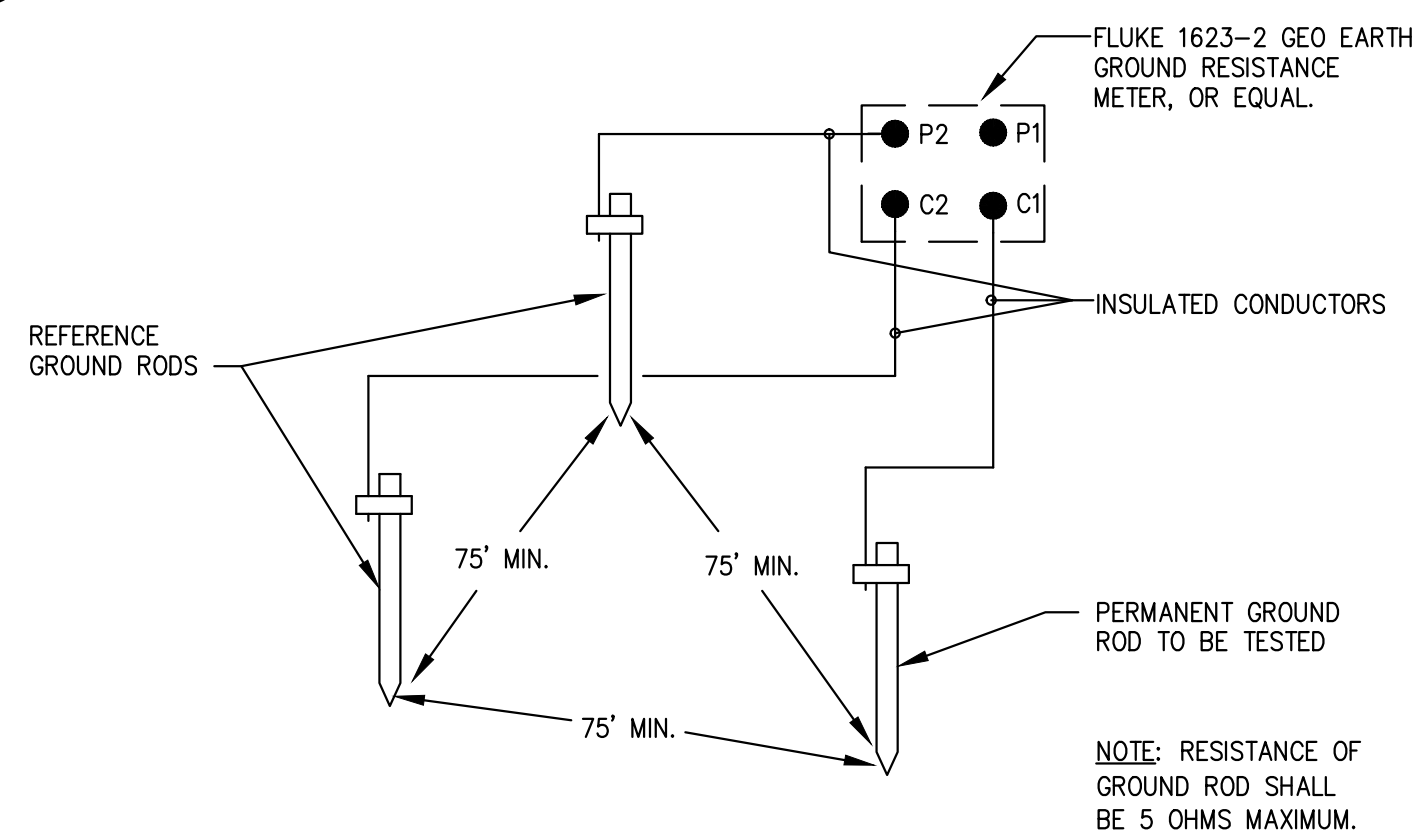

- FALL OF POTENTIAL TEST METHOD NOTES:
- POWER EQUIPMENT OR SYSTEMS WITH CAPACITY OF 500KVA OR LESS: 10 OHMS.
 - POWER EQUIPMENT OR SYSTEMS WITH CAPACITY OF 500 TO 1000KVA: 5 OHMS.
 - POWER EQUIPMENT OR SYSTEMS WITH CAPACITY GREATER THAN 1000KVA: 3 OHMS.
 - POWER DISTRIBUTION UNITS OR PANELBOARDS SERVING ELECTRONIC I.T. EQUIPMENT: 3 OHMS.
 - MAN-HOLE GROUNDS: 10 OHMS.
- FALL OF POTENTIAL 3-POINT TEST: GROUND RING, I.E. 10 BY 10 RING, 14' DIAGONAL LENGTH ISOLATION FROM UTILITY NEUTRAL PROBE Z IS DRIVEN A DISTANCE OF 10 TIMES DIAGONAL LENGTH OF THE GROUNDING ROD SYSTEM (ROD X). A SECOND PROBE (Y) IS PLACED IN LINE AT A DISTANCE FROM ROD X EQUAL TO THE DIAGONAL LENGTH OF THE GROUNDING SYSTEM.

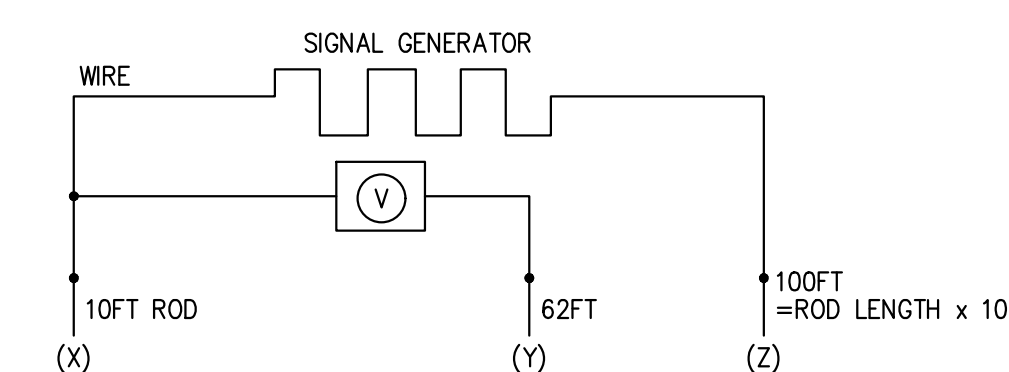

AT THIS POINT, A KNOWN CURRENT IS APPLIED ACROSS X & Z, WHILE THE RESULTING VOLTAGE IS MEASURED ACROSS X & Y. OHMS LAW APPLIED $R=V/I$. THEN (Y) MOVED TO 2 TIMES THE DIAGONAL LENGTH, THEN MOVE OUT TO 3 TIMES(3X), 4X, ... 9X THE DIAGONAL LENGTH TO COMPLETE THE 3 POINT TEST WITH A TOTAL OF NINE RESISTANCE MEASUREMENTS.

6 METHOD OF TESTING GROUND RODS DETAIL
SCALE: NONE

1 DETAIL REMOVED
SCALE: NONE

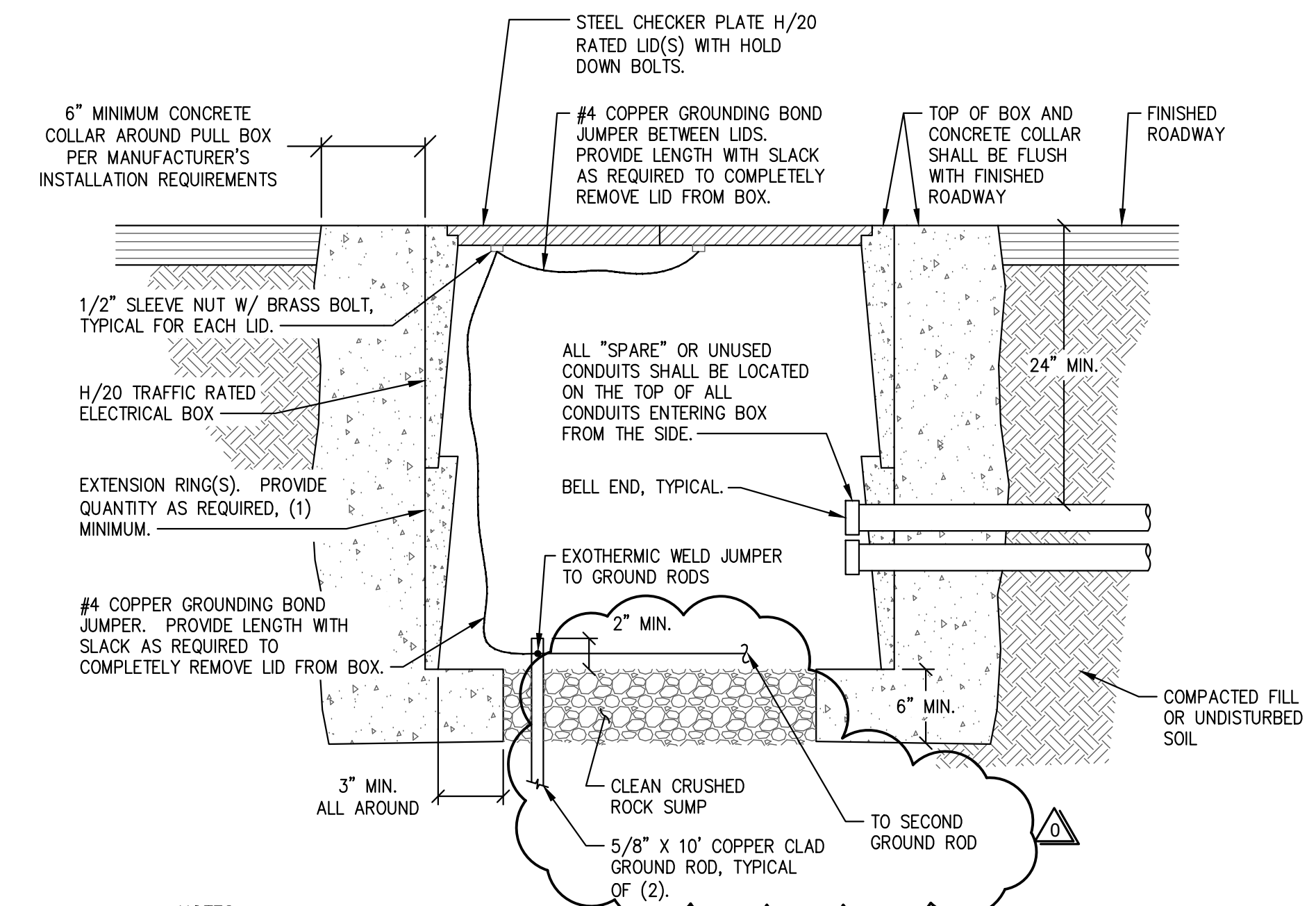

2 TYPICAL H/20 TRAFFIC RATED PULL BOX
SCALE: NONE

- NOTES:
- PROVIDE H/20 TRAFFIC RATED BOXES IN ALL LOCATIONS WITH VEHICLE TRAFFIC
 - CONTRACTOR SHALL PROVIDE THE MANUFACTURER'S INSTALLATION INSTRUCTIONS FOR H/20 TRAFFIC RATING REQUIREMENTS AS PART OF THE SUBMITTALS.

3 TYPICAL TRENCH DETAIL
SCALE: NONE

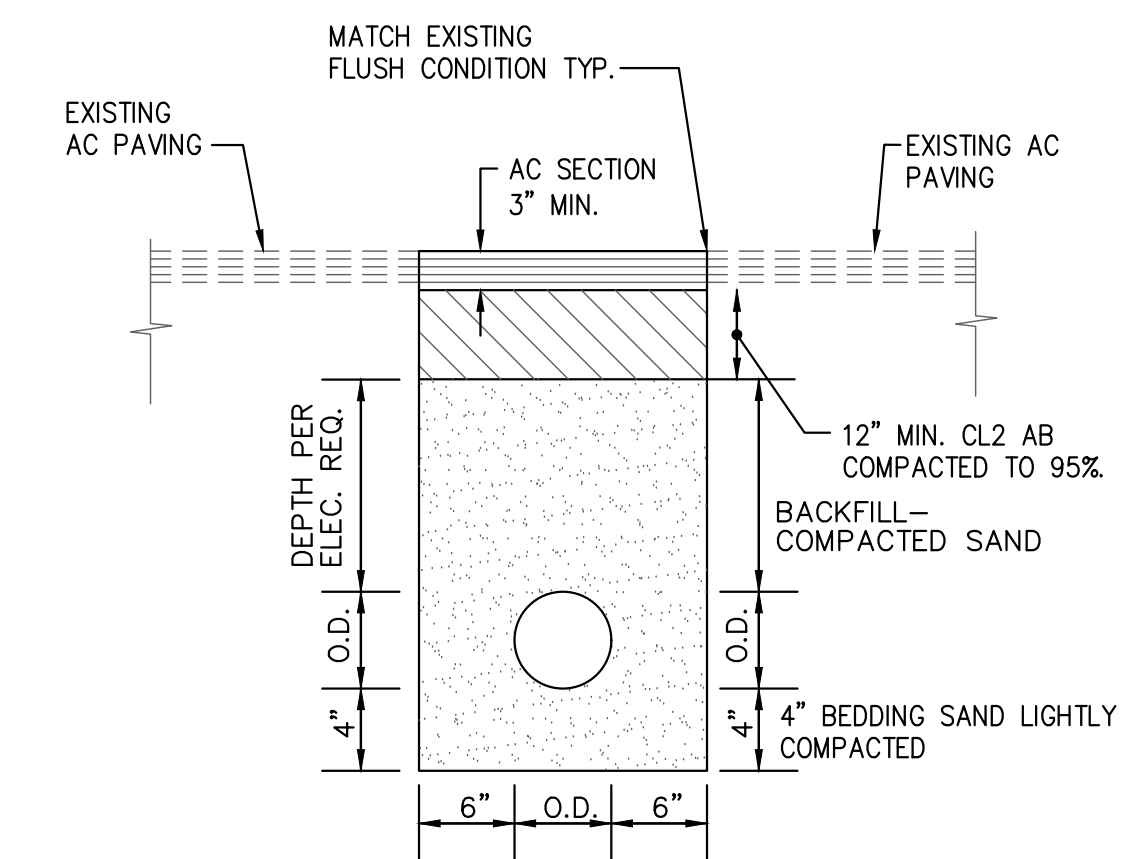

Revision	DATE
ADDENDUM	04/29/22

Copyright © 2021 Rainforth Grau Architects. All rights reserved. Reproduction of these plans, either in whole or in part, including any form of copying and/or preparation of derivative works thereof, for any reason without prior written permission, is strictly prohibited.

DETAILS

Statement of General Conformance

THE FOLLOWING DRAWINGS OR SHEETS LISTED ON THE COVER OR INDEX SHEET HAVE BEEN PREPARED BY OTHER DESIGN PROFESSIONALS OR CONSULTANTS WHO ARE LICENSED AND/OR AUTHORIZED TO PREPARE SUCH DRAWINGS IN THIS STATE. IT HAS BEEN EXAMINED BY ME FOR:

- 1) DESIGN INTENT AND APPEARS TO MEET THE APPROPRIATE REQUIREMENTS OF TITLE 24, CALIFORNIA CODE OF REGULATIONS AND THE PROJECT SPECIFICATIONS PREPARED BY ME, AND
- 2) COORDINATION WITH MY PLANS AND SPECIFICATIONS AND IS ACCEPTABLE FOR INCORPORATION INTO THE CONSTRUCTION OF THIS PROJECT.

THE STATEMENT OF GENERAL CONFORMANCE "SHALL NOT BE CONSTRUED AS RELIEVING ME OF MY RIGHTS, DUTIES, AND RESPONSIBILITIES UNDER SECTIONS 17302 AND 81138 OF THE EDUCATION CODE AND SECTIONS 4-336, 4-341, AND 4-344" OF TITLE 24, PART 1. (TITLE 24, PART 1, SECTION 4-317 (b))



SIGNATURE

4/21/22

DATE

ARCHITECT OR ENGINEER DESIGNATED TO BE IN GENERAL RESPONSIBLE CHARGE

Jeffrey Grau

PRINT NAME

C-14648

05/31/23

LICENSE NUMBER

EXPIRATION DATE

LIST COMPLETELY, ITEMS REVIEWED AND ACCEPTED:

PC SHADE STRUCTURE

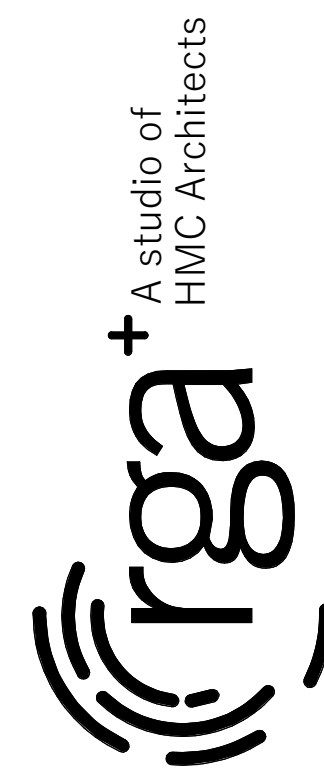
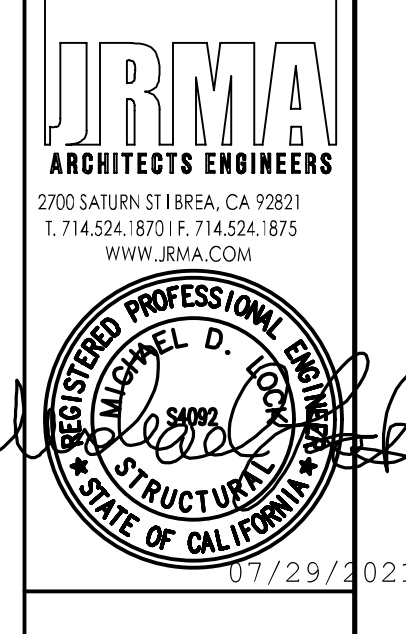
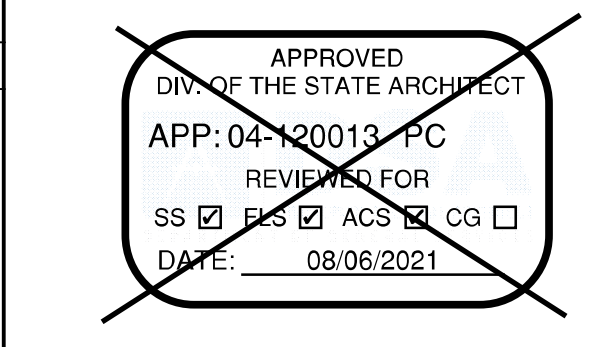

Table with columns: ICON STD, R4/DSA-PC, DRAWN BY, DATE, REV, REV DATE



02/29/2021



DESIGN CRITERIA table with columns: DESCRIPTION, DESIGN VALUES. Includes sections for DEAD AND LIVE LOADS, WIND DESIGN, SEISMIC DESIGN, and FLOOD DESIGN.

GENERAL. 1. GENERAL NOTES AND TYPICAL DETAILS SHALL APPLY TO ALL PARTS OF THE JOB EXCEPT WHERE THEY MAY CONFLICT WITH DETAILS AND NOTES ON OTHER SHEETS...

STRUCTURAL AND MISCELLANEOUS STEEL. 1. ALL STRUCTURAL STEEL SHALL BE DETAILED, FABRICATED AND ERRECTED IN ACCORDANCE WITH THE AMERICAN INSTITUTE OF STEEL CONSTRUCTION (AISC) SPECIFICATION MANUAL...

WELDING. 1. ALL WELDING SHALL COMPLY WITH AWS D11.1 SPECIFICATIONS AND SHALL BE DONE BY AWS QUALIFIED WELDERS CERTIFIED WITH DETAILS AND NOTES ON OTHER SHEETS...

FOUNDATIONS. 1. ALLOWABLE SOIL REQUIREMENTS ASSUME CLASS 5 SOIL CLASSIFICATION PER CBC TABLE 1806A, UNLESS NOTED OTHERWISE.

Table with columns: STRENGTH Pz (28 DAYS), W/C RATIO (NON-AIR ENTRAINED), W/C RATIO (AIR ENTRAINED), SLUMP (in), UNIT WEIGHT (NORMAL WEIGHT), UNIT WEIGHT (150 PCF)

Table with columns: STEP 1, STEP 2, STEP 3, STEP 4, STEP 5, STEP 6, STEP 7, STEP 8, STEP 9, STEP 10. Includes project name, school district, and various design parameters.

REINFORCING STEEL. 1. REINFORCING STEEL SHALL BE DEFORMED STEEL CONFORMING TO THE REQUIREMENTS OF ASTM A-615, AS FOLLOWS: GR 60 (#4 BARS AND LARGER) GR 40 (#3 BARS)

ABBREVIATIONS table with columns: ACI, AISC, ASM, ASTM, AWS, CBC, C/P, CLR, DEG, DIA, DIM, DSA, EQ, FT, GA, IN, INSI, MAX, MIN, MISC. Lists various codes and their meanings.

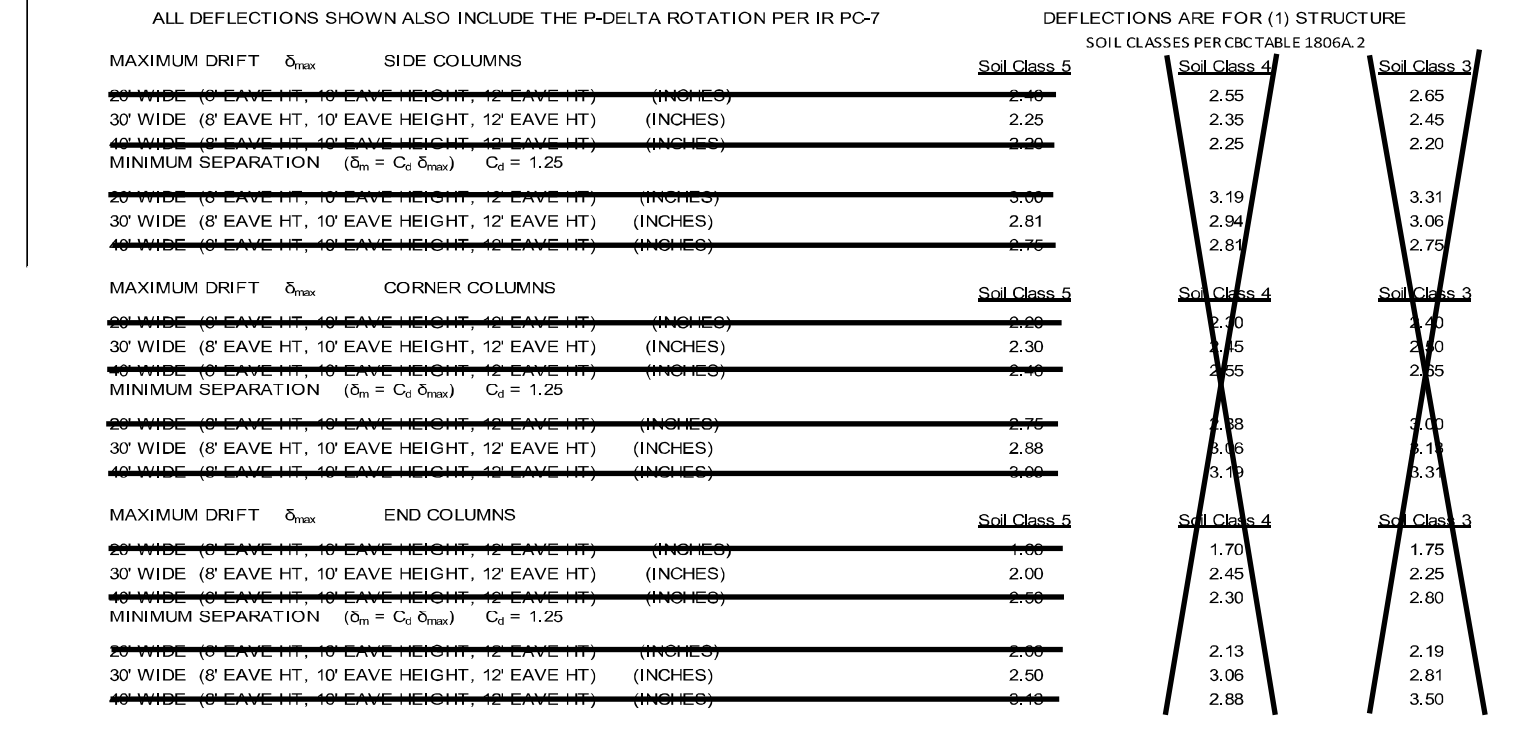

INSTRUCTIONS FOR ARCHITECTS SUBMITTING THESE PRE-CHECKED DRAWING TO DSA. BEFORE SUBMITTING THESE PRE-CHECKED DRAWINGS FOR YOUR PROJECT, FOLLOW THE STEPS BELOW TO PROPERLY DEFINE THE APPROVED OPTIONS:

ARCHITECTURAL REQUIREMENTS table with columns: DESCRIPTION, DESIGN VALUES. Includes type of construction, occupancy classification, number of stories, fire sprinkler system.

RELATED BUILDING CODES AND STANDARDS. TITLE 24 CODES: 2019 CALIFORNIA ADMINISTRATIVE CODE (CAC) (PART 1, TITLE 24, CCR) 2019 CALIFORNIA BUILDING CODE (CBC), VOLUMES 1, AND 2 (PART 2, TITLE 24, CCR)

Table with columns: STEP 1, STEP 2, STEP 3, STEP 4, STEP 5, STEP 6, STEP 7, STEP 8, STEP 9, STEP 10. Includes project name, school district, and various design parameters.

Table with columns: DESCRIPTION, TOTAL ROOF DEAD LOAD, DEAD LOAD, EXAMPLES. Includes roof deck, collateral, and total load values.

CONSTRUCTION NOTES. 1. A DSA-CERTIFIED CLASS 3 PROJECT INSPECTOR IS REQUIRED FOR THIS PROJECT. 2. CHANGES TO THE APPROVED DRAWINGS AND SPECIFICATIONS SHALL BE MADE BY ADDENDA OR CONSTRUCTION CHANGE DOCUMENT (CCD) APPROVED BY DSA...

Table with columns: STEP 7, STEP 8. Includes miscellaneous design options and sheet index table.

DESIGN CRITERIA FOR 7525 CANDLEWOOD WAY, SACRAMENTO, CA 95822. Table with columns: DESCRIPTION, DESIGN VALUES. Includes wind design, risk category, exposure category, seismic design.

GENERAL INFO



1455 LINCOLN AVE, HOLLAND MI, 49423. 616.396.0919, 800.748.0985, 616.396.0944 FX

PRE-CHECK (PC) DOCUMENT Code: 2019 CBC A separate project application for construction is required.

SHADE STRUCTURE AT JOHN D. SLOAT ELEMENTARY SCHOOL SACRAMENTO CITY UNIFIED SCHOOL DISTRICT SACRAMENTO, CA

Revision

Copyright © 2021 Rainforth Grau Architects. All rights reserved. Reproduction of these plans, either in whole or in part, including any form of copying and/or preparation of derivative works therefor, for any reason without prior written permission, is strictly prohibited. GENERAL INFO

PROJECT NO. 21-1504.06 DATE: 4/7/22 SHEET LS1.0

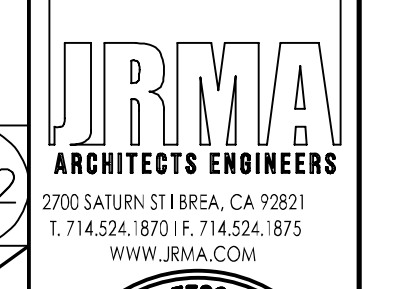
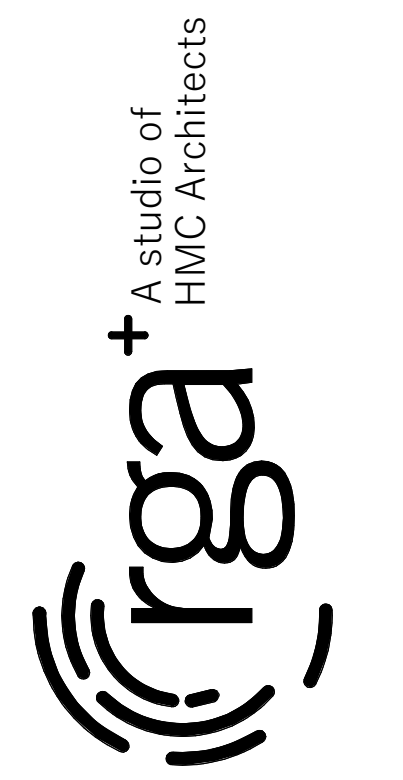

APPROVED
 DIV. OF THE STATE ARCHITECT
 APP: 04-120013-PC
 REVIEWED FOR
 SS FILE ACS CG
 DATE: 08/06/2021

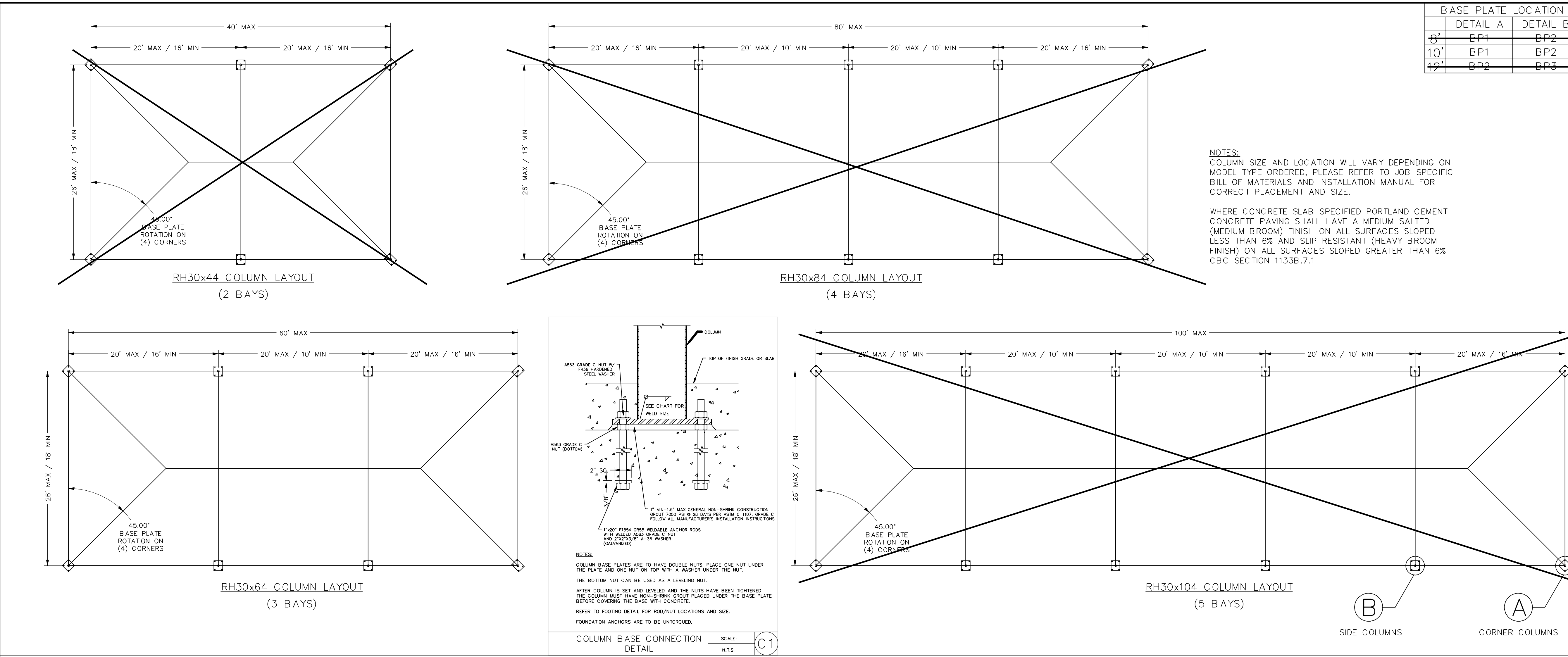

BASE PLATE LOCATION		
DETAIL A	DETAIL B	
6"	BP1	BP2
10"	BP1	BP2
12"	BP2	BP3

NOTES:
 COLUMN SIZE AND LOCATION WILL VARY DEPENDING ON MODEL TYPE ORDERED, PLEASE REFER TO JOB SPECIFIC BILL OF MATERIALS AND INSTALLATION MANUAL FOR CORRECT PLACEMENT AND SIZE.
 WHERE CONCRETE SLAB SPECIFIED PORTLAND CEMENT CONCRETE PAVING SHALL HAVE A MEDIUM SALTED (MEDIUM BROOM) FINISH ON ALL SURFACES SLOPED LESS THAN 6% AND SLIP RESISTANT (HEAVY BROOM FINISH) ON ALL SURFACES SLOPED GREATER THAN 6% CBC SECTION 1133B.7.1

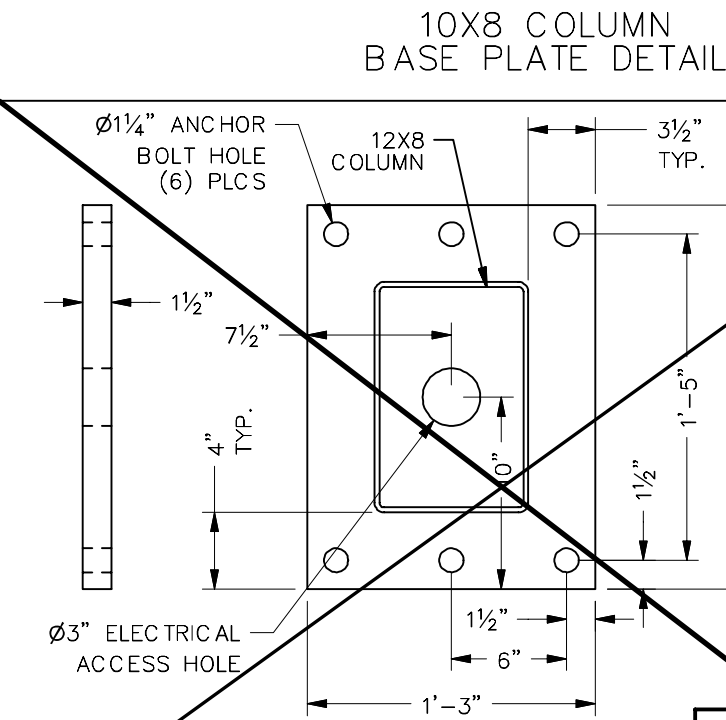
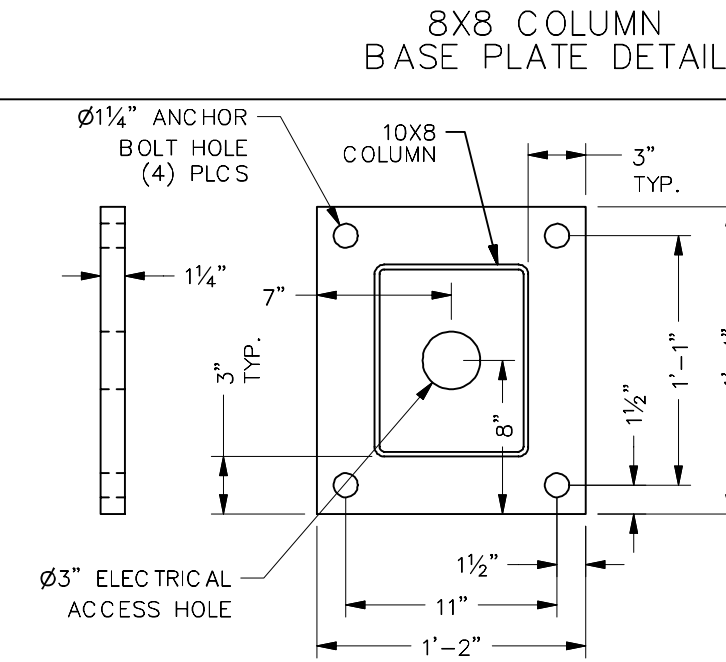
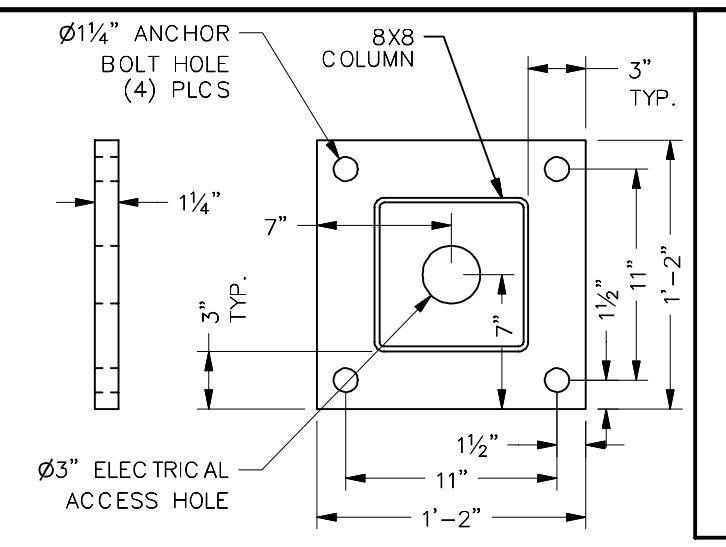

30' WIDE RECTANGULAR HIP

RH30 - PIER												
8' height - Corner Columns			8' height - Corner Columns			8' height - Corner Columns			8' height - Corner Columns			
Soil Class 5 - 1500 psf Bearing			Soil Class 4 - 2000 psf Bearing			Soil Class 3 - 3000 psf Bearing			Soil Class 3 - 3000 psf Bearing			
Dia (A)	Depth (B)	Rebar Qty	Dia (A)	Depth (B)	Rebar Qty	Dia (A)	Depth (B)	Rebar Qty	X (in)	Y (in)	Rebar Size	Fillet Weld "W"
24	114	6	24	98	6	24	88	6	14	40	5	1/4
8' height - Side Columns			8' height - Side Columns			8' height - Side Columns			8' height - Side Columns			
36	144	12	30	132	6	30	118	6	16	40	5	1/4
10' height - Corner Columns			10' height - Corner Columns			10' height - Corner Columns			10' height - Corner Columns			
24	120	6	24	102	6	24	92	6	14	40	5	1/4
10' height - Side Columns			10' height - Side Columns			10' height - Side Columns			10' height - Side Columns			
36	136	12	30	124	8	30	112	8	16	40	5	1/4
12' height - Corner Columns			12' height - Corner Columns			12' height - Corner Columns			12' height - Corner Columns			
30	132	8	30	112	8	30	102	8	16	40	5	5/16
12' height - Side Columns			12' height - Side Columns			12' height - Side Columns			12' height - Side Columns			
36	140	12	36	120	12	36	108	12	20	40	5	1/4

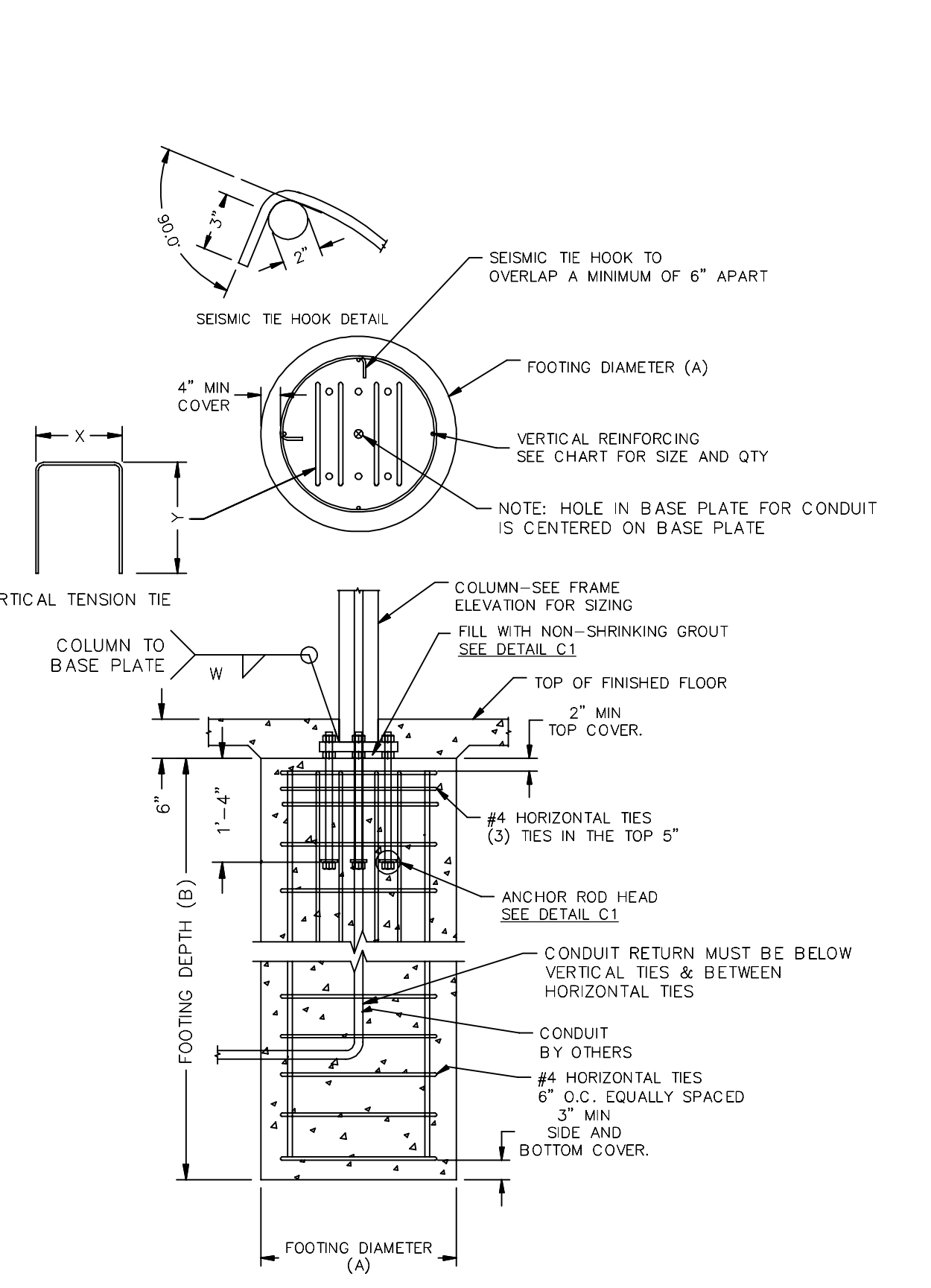

RH30 - SPREAD														
8' height - Corner Columns			8' height - Corner Columns			8' height - Corner Columns			8' Corner Columns					
Soil Class 5 - 1500 psf Bearing			Soil Class 4 - 2000 psf Bearing			Soil Class 3 - 3000 psf Bearing			Soil Class 3 - 3000 psf Bearing					
Size (A)	Depth (B)	T&B Rebar Qty	Size (A)	Depth (B)	T&B Rebar Qty	Size (A)	Depth (B)	T&B Rebar Qty	X (in)	Y (in)	B (in)	C (in)	Rebar Size	Fillet Weld "W"
60	30	6	56	30	4	54	30	4	14	20	15.9	17.3	5	1/4
8' height - Side Columns			8' height - Side Columns			8' height - Side Columns			8' Side Columns					
80	30	5	72	30	5	68	30	5	16	20	15.6	19.3	5	1/4
10' height - Corner Columns			10' height - Corner Columns			10' height - Corner Columns			10' Corner Columns					
66	30	5	60	30	4	57	30	4	14	20	15.9	17.3	5	1/4
10' height - Side Columns			10' height - Side Columns			10' height - Side Columns			10' Side Columns					
81	30	5	72	30	5	69	30	5	16	20	15.6	19.3	5	1/4
12' height - Corner Columns			12' height - Corner Columns			12' height - Corner Columns			12' Corner Columns					
78	30	5	72	30	5	72	30	5	16	20	15.6	19.3	5	5/16
12' height - Side Columns			12' height - Side Columns			12' height - Side Columns			12' Side Columns					
84	30	6	75	30	5	75	30	5	20	20	16.6	21.3	5	1/4

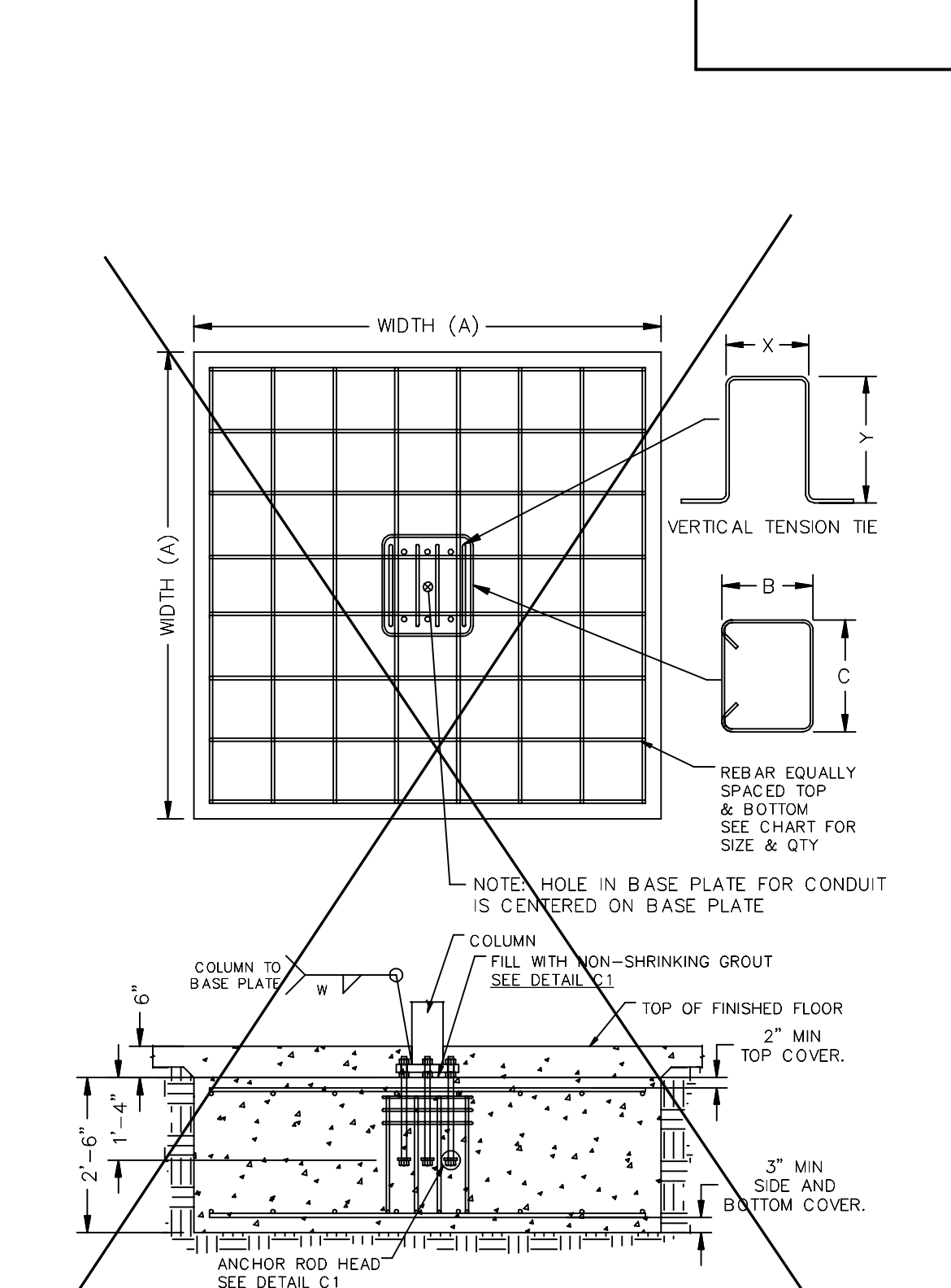

SEE DETAILS BP1, BP2 OR BP3 FOR ANCHOR BOLT PATTERNS
 BP1 & BP2 ARE (4) BOLT PATTERN WHILE BP3 IS A (6) BOLT

SEE DETAILS BP1, BP2 OR BP3 FOR ANCHOR BOLT PATTERNS
 BP1 & BP2 ARE (4) BOLT PATTERN WHILE BP3 IS A (6) BOLT

PRE-CHECK (PC) DOCUMENT
 Code: 2019 CBC
 A separate project application for construction is required.

LS3.0

PRINTED ON:

SHADE STRUCTURE AT JOHN D. SLOAT
 ELEMENTARY SCHOOL

SACRAMENTO CITY UNIFIED SCHOOL DISTRICT
 SACRAMENTO, CA

Revision

30' WIDE RECTANGULAR HIP FOUNDATION PLAN

Copyright © 2021 Rainforth Grau Architects. All rights reserved. Reproduction of these plans, either in whole or in part, including any form of copying and/or preparation of derivative works thereof, for any reason without prior written permission, is strictly prohibited.

1455 LINCOLN AVE
 HOLLAND MI, 49423
 616.396.0919
 800.748.0985
 616.396.0944 FX

PROJECT NO. 21-1504.06
 DATE: 4/7/22
 SHEET

LS3.0
 AD0.09

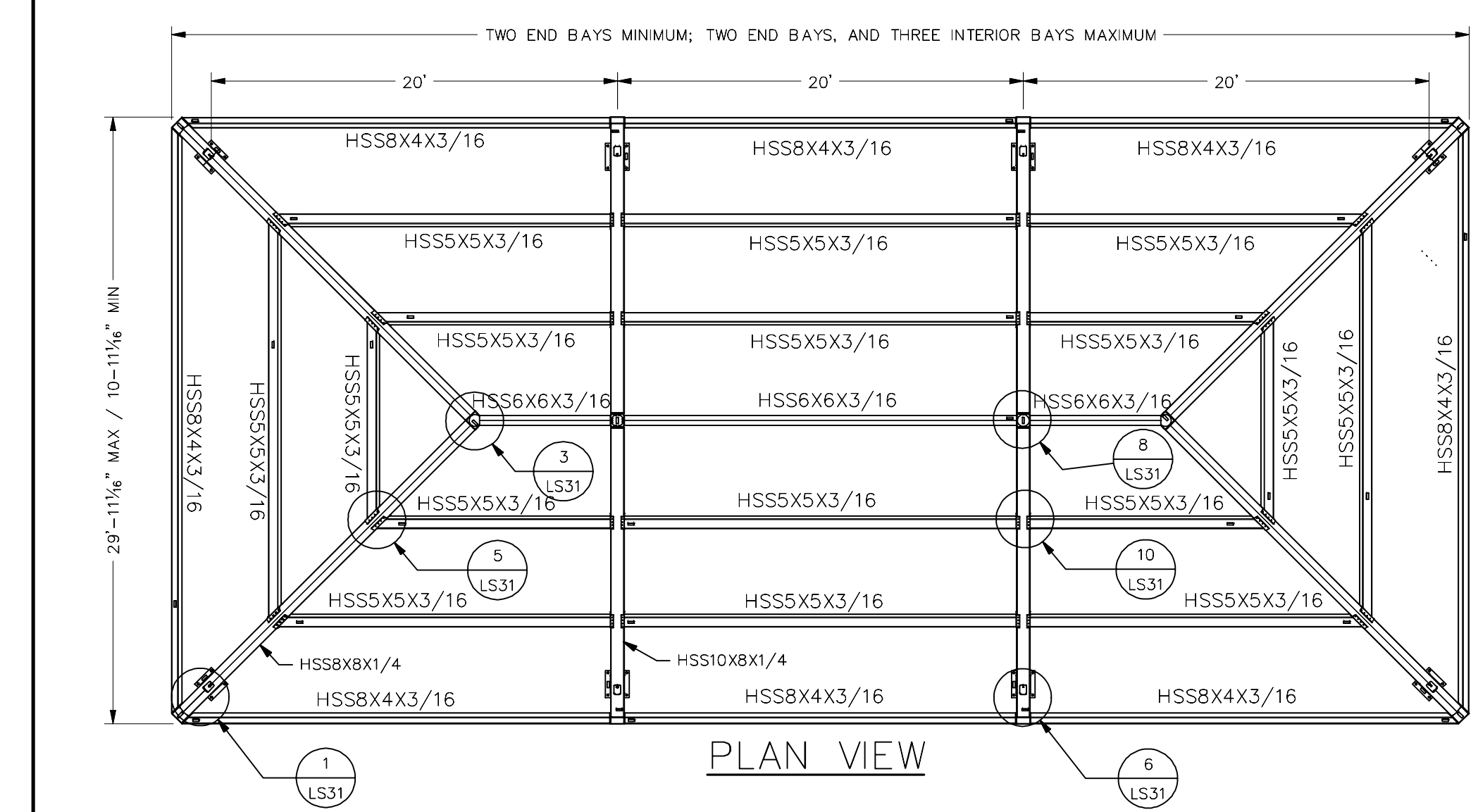
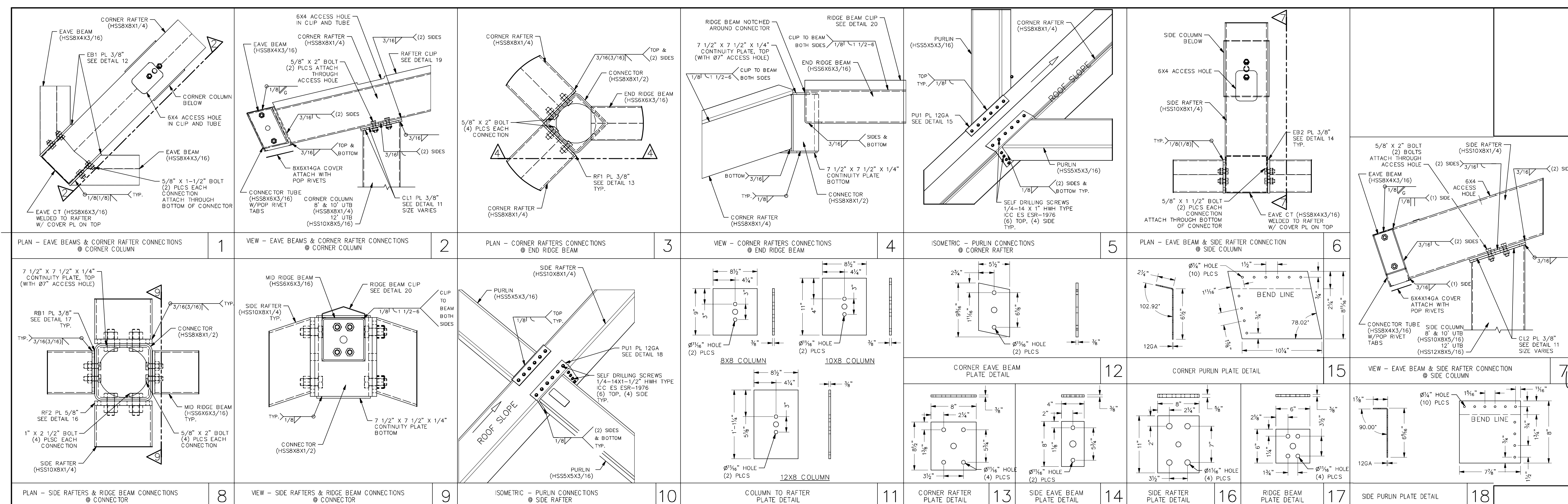

**NOTE:
QUANTITIES WILL VARY DEPENDING ON SHELTER SIZE ORDERED, PLEASE
REFER TO JOB SPECIFIC BILL OF MATERIALS AND INSTALLATION MANUAL.

ITEM	QTY	PART NUMBER	DESCRIPTION	MATERIAL	LENGTH	UNIT WEIGHT
1	4		CORNER COLUMN	**SEE NOTE BELOW		353 lbmass
2	*		SIDE COLUMN	**SEE NOTE BELOW		399 lbmass
3	2		LH SIDE EAVE BEAM	HSS8X4X3/16		311 lbmass
4	2		RH SIDE EAVE BEAM	HSS8X4X3/16		311 lbmass
5	2		END EAVE BEAM	HSS8X4X3/16		422 lbmass
6	*		SIDE EAVE BEAM	HSS8X4X3/16		287 lbmass
7	4		CORNER RAFTER	HSS8X8X1/4		607 lbmass
8	*		SIDE RAFTER	HSS10X8X1/4		474 lbmass
9	2		END RIDGE BEAM	HSS8X6X3/16		149 lbmass
10	*		MID RIDGE BEAM	HSS8X6X3/16		328 lbmass
11	*		CONNECTOR	HSS8X8X1/2		48 lbmass
12	2		LH SIDE PURLIN 1	HSS5X5X3/16		238 lbmass
13	2		RH SIDE PURLIN 1	HSS5X5X3/16		238 lbmass
14	2		END PURLIN 1	HSS5X5X3/16		278 lbmass
15	2		LH SIDE PURLIN 2	HSS5X5X3/16		167 lbmass
16	2		RH SIDE PURLIN 2	HSS5X5X3/16		167 lbmass
17	2		END PURLIN 2	HSS5X5X3/16		137 lbmass
18	*		MID PURLIN	HSS5X5X3/16		284 lbmass

**NOTE:
MATERIAL WILL VARY DEPENDING ON SHELTER SIZE ORDERED.

- CORNER COLUMN 8' UTB - (HSS8X8X1/4)
- SIDE COLUMN 8' UTB - (HSS10X8X5/16)
- CORNER COLUMN 10' UTB - (HSS8X8X1/4)
- SIDE COLUMN 10' UTB - (HSS10X8X5/16)
- CORNER COLUMN 12' UTB - (HSS10X8X5/16)
- SIDE COLUMN 12' UTB - (HSS12X8X5/16)

MODEL DESIGNATION

RH30X44	2 BAY
RH30X64	3 BAY
RH30X84	4 BAY
RH30X104	5 BAY

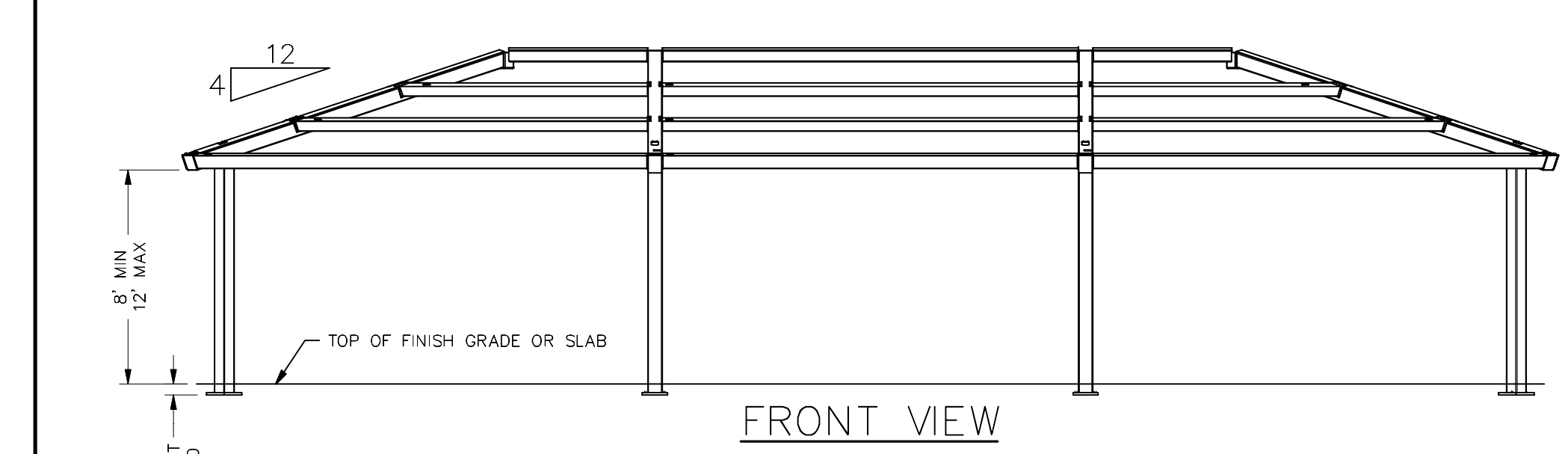

30' WIDE RECTANGULAR HIP

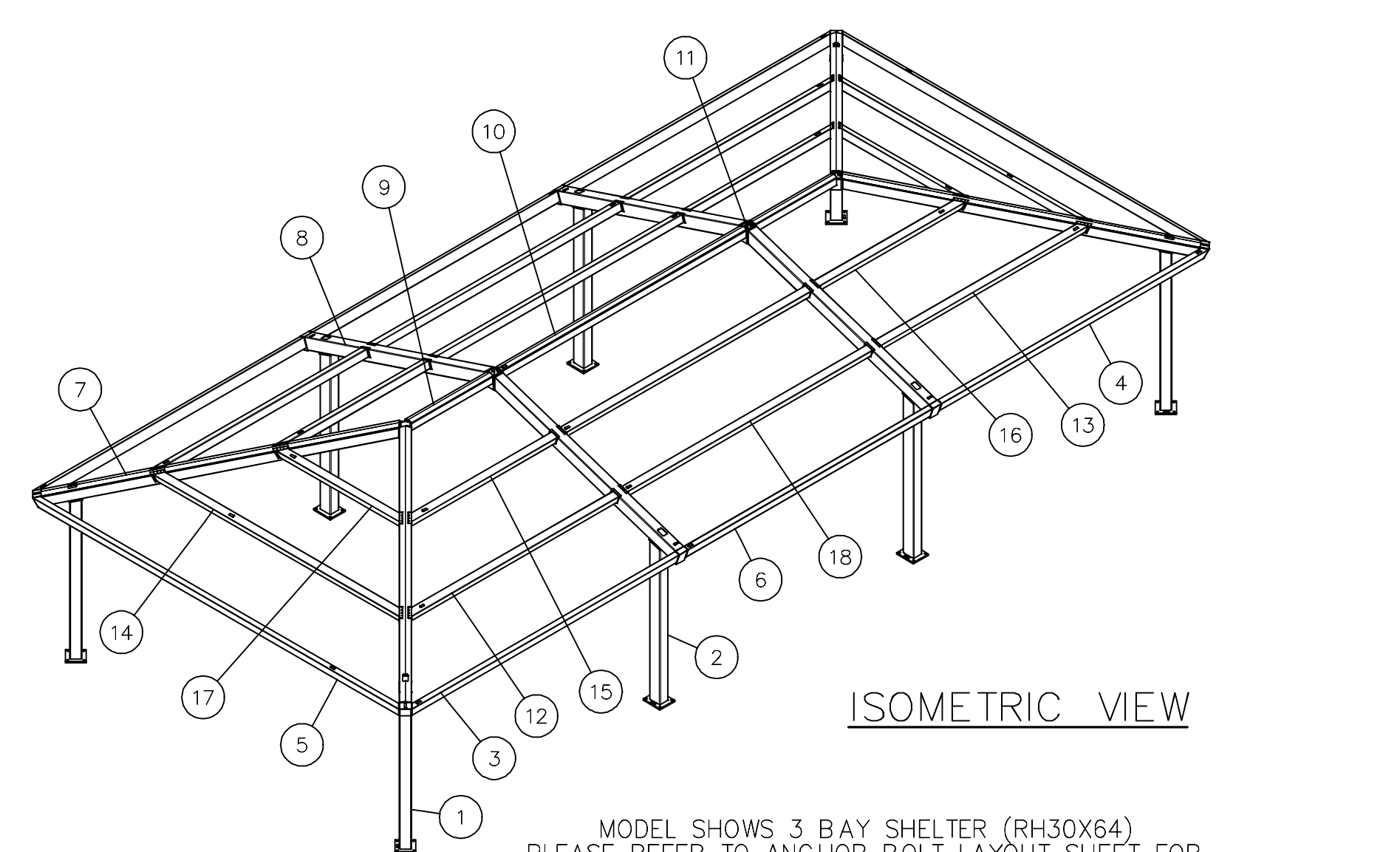
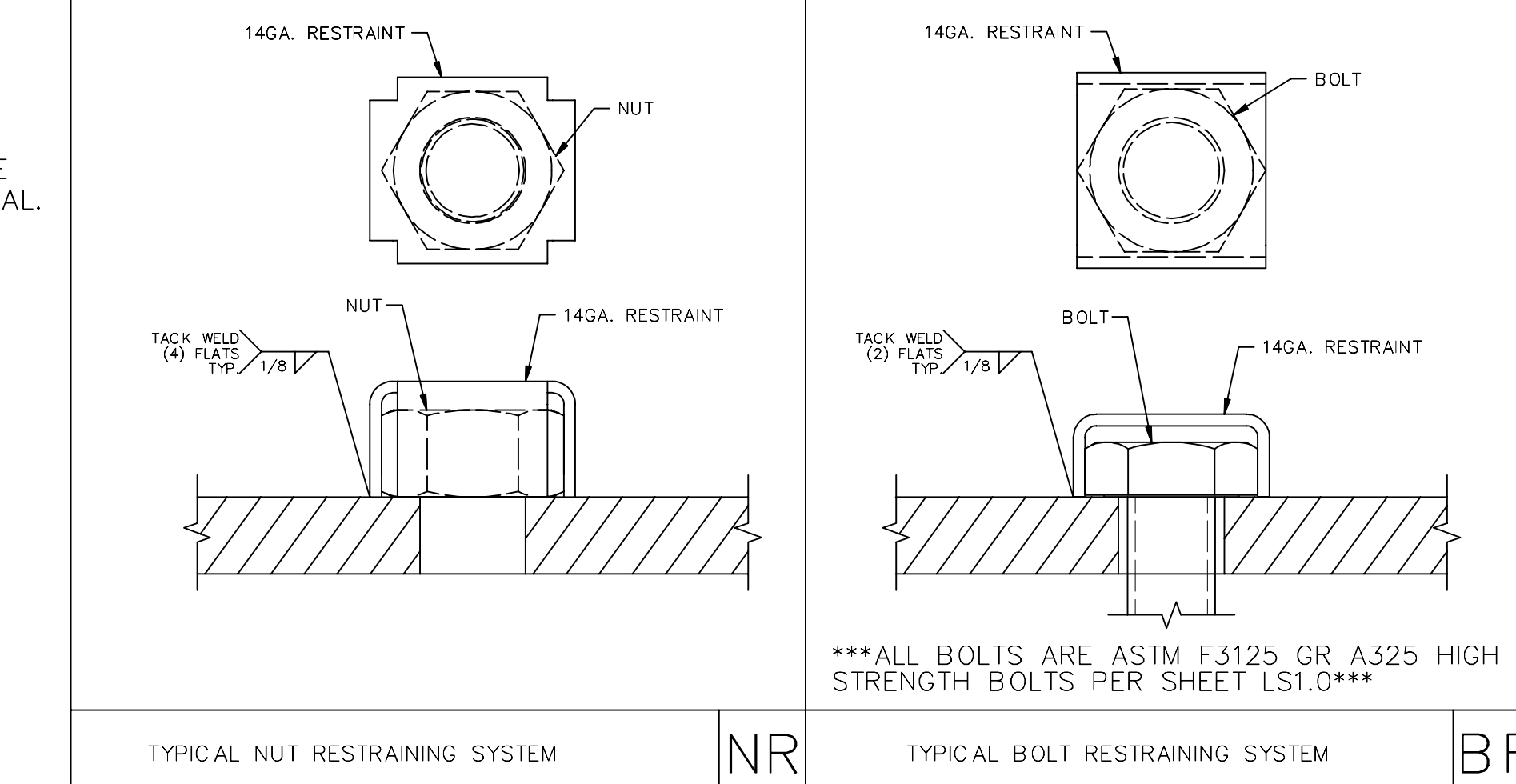

MODEL SHOWS 3 BAY SHELTER (RH30X64)
PLEASE REFER TO ANCHOR BOLT LAYOUT SHEET FOR
CORRECT COLUMN PLACEMENT BASED ON SIZE ORDERED

APPROVED
DIV. OF THE STATE ARCHITECT
APP: 04-20013 PC
REVIEWED FOR
SS □ PLS □ ACS □ CG □
DATE: 08/06/2021

30' WIDE
RECTANGULAR HIP
FRAMING &
CONNECTION DETAILS

Shelter Systems Inc
DISTINCTIVE STEEL SHELTER SYSTEMS, INC.
WWW.ICONSHELTERS.COM
1455 LINCOLN AVE
HOLLAND MI, 49423
616.396.0919
800.748.0985
616.396.0944 FX

LS3.1

PRE-CHECK (PC) DOCUMENT
Code: 2019 CBC
A separate project application for construction is required.

SHADE STRUCTURE AT JOHN D. SLOAT
ELEMENTARY SCHOOL

SACRAMENTO CITY UNIFIED SCHOOL DISTRICT
SACRAMENTO, CA

Revision

30' WIDE
RECTANGULAR HIP
FRAMING &
CONNECTION DETAILS

LS3.1

ELECTRICAL INFORMATION - RECTANGULAR HIP

ICON'S STANDARD ELECTRICAL IS DESIGNED TO ACCOMMODATE Ø1/2" CONDUIT WITH A Ø3" INLET HOLE ON THE BOTTOM OF EACH COLUMN. THE CONDUIT PATHWAY RUNS THROUGH THE COLUMN, RAFTER, AND RIDGE BEAM THROUGH ALL BOLTED CONNECTIONS AS SHOWN. IF YOU HAVE SPECIAL ELECTRICAL REQUIREMENTS, PLEASE OUTLINE ANY CHANGES BELOW AS DESCRIBED.

PLEASE NOTE: DESIGN LIMITATIONS ON HOLE/CUTOUT SIZES MAY APPLY. ICON WILL REACH OUT TO DISCUSS ANY SUCH LIMITATIONS AS NEEDED.

NOTE: ICON SHELTER FRAME IS NOT UL LISTED TO ACT AS A CONDUIT FOR ELECTRICAL WIRING. CONSULT LOCAL BUILDING CODES WHEN PLANNING YOUR ELECTRICAL SYSTEM.

PRELIMINARY: NOT FOR CONSTRUCTION

- STEPS:**
1. CONDUIT HOLE SIZE (DETAIL A)
 2. ELECTRICAL EXIT HOLES (DETAIL B)
 3. ELECTRICAL ACCESS & COVER PLATES (DETAIL C)
 4. ELECTRICAL CONDUIT PATHWAY (DETAIL D)

IF REQUIRED, PLEASE DRAW THE NECESSARY ELECTRICAL CONDUIT PATHWAY ON THE FRAME SHEET OF THIS PRELIMINARY.

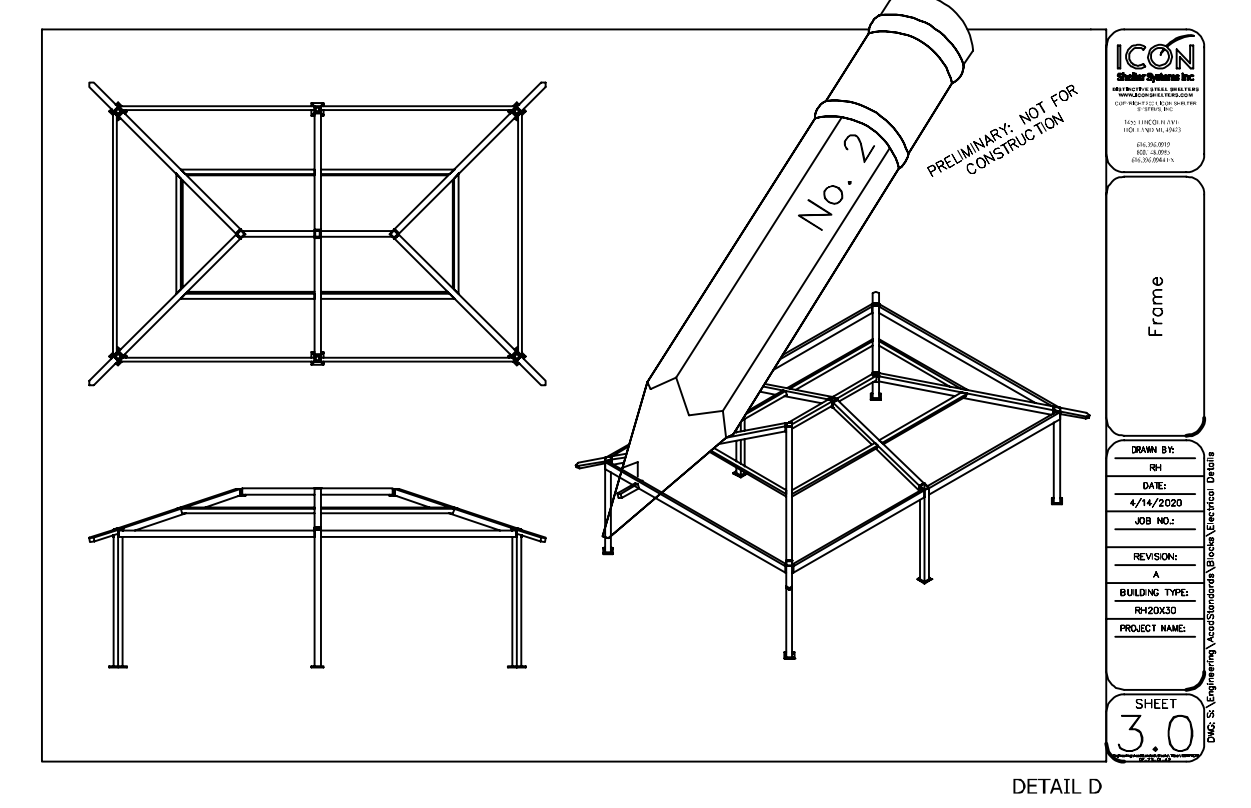

OPTIONAL EXIT HOLES
 IF REQUIRED, EXIT HOLES FOR LIGHTING, ETC. CAN BE PLACED IN THE RIDGE BEAM AND/OR CONNECTOR TUBE WITH 14ga COVER PLATE AS SHOWN (CHARGES APPLY). USE FRAME SHEET OF THIS PRELIMINARY TO SPECIFY REQUIRED EXIT HOLE LOCATIONS AND SIZE.

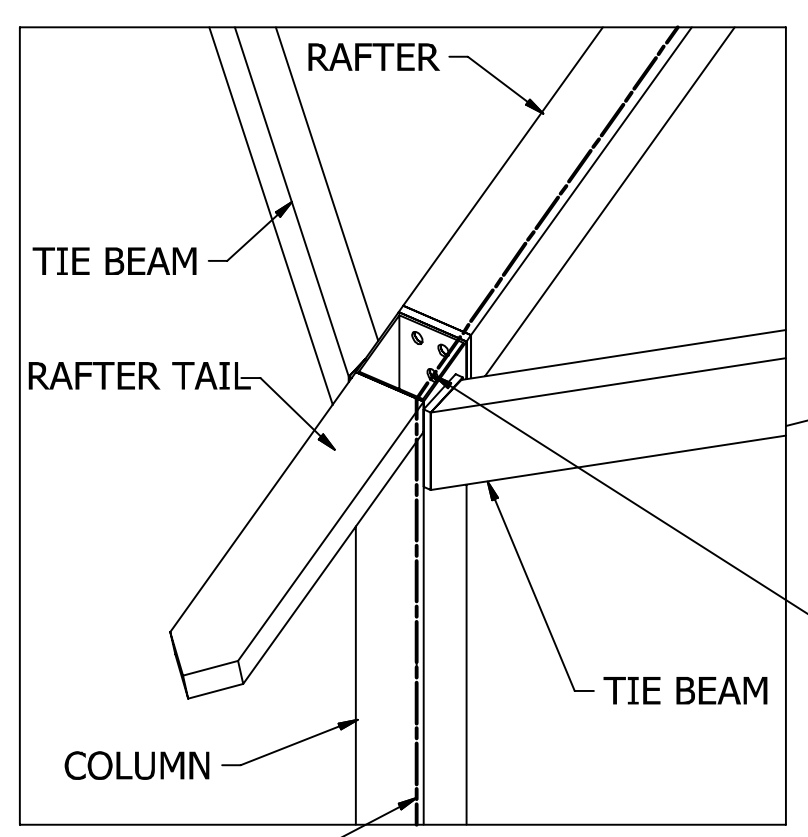
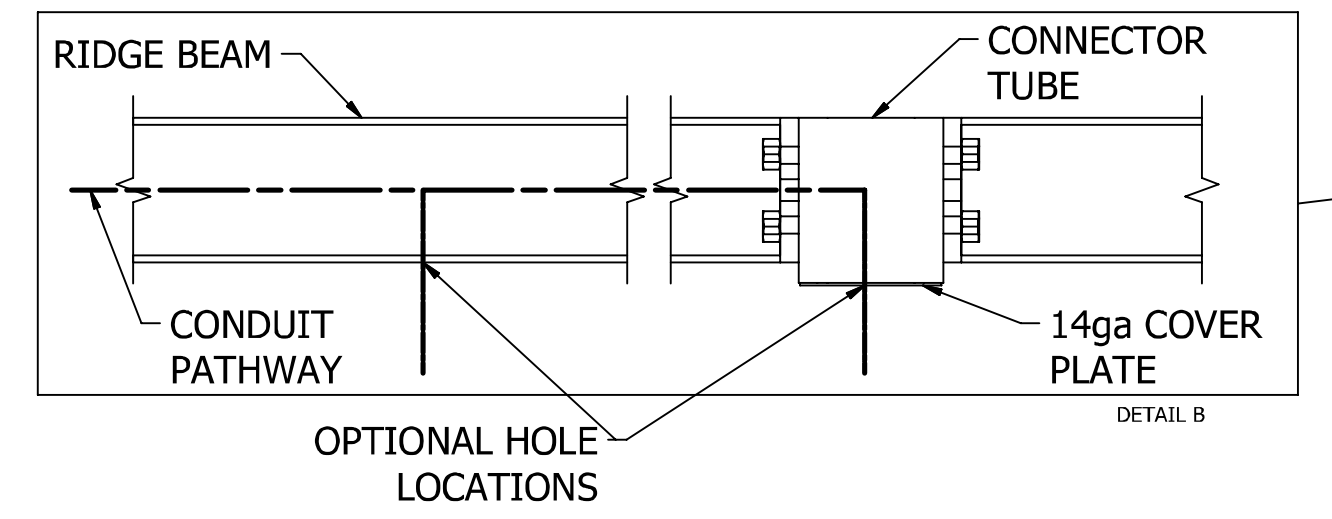

ICON PROVIDES A MINIMUM OF (1) 3/4" HOLE AT EACH CONNECTION FOR 1/2" CONDUIT. IF APPLICABLE, PLEASE SPECIFY REQUIRED CONDUIT SIZE: (CHARGES APPLY)

- 3/4" CONDUIT (1" HOLES)
- 1" CONDUIT (1 1/4" HOLES)
- OTHER (PLEASE SPECIFY)

CONDUIT PATHWAY PROVIDED FOR EACH COLUMN.

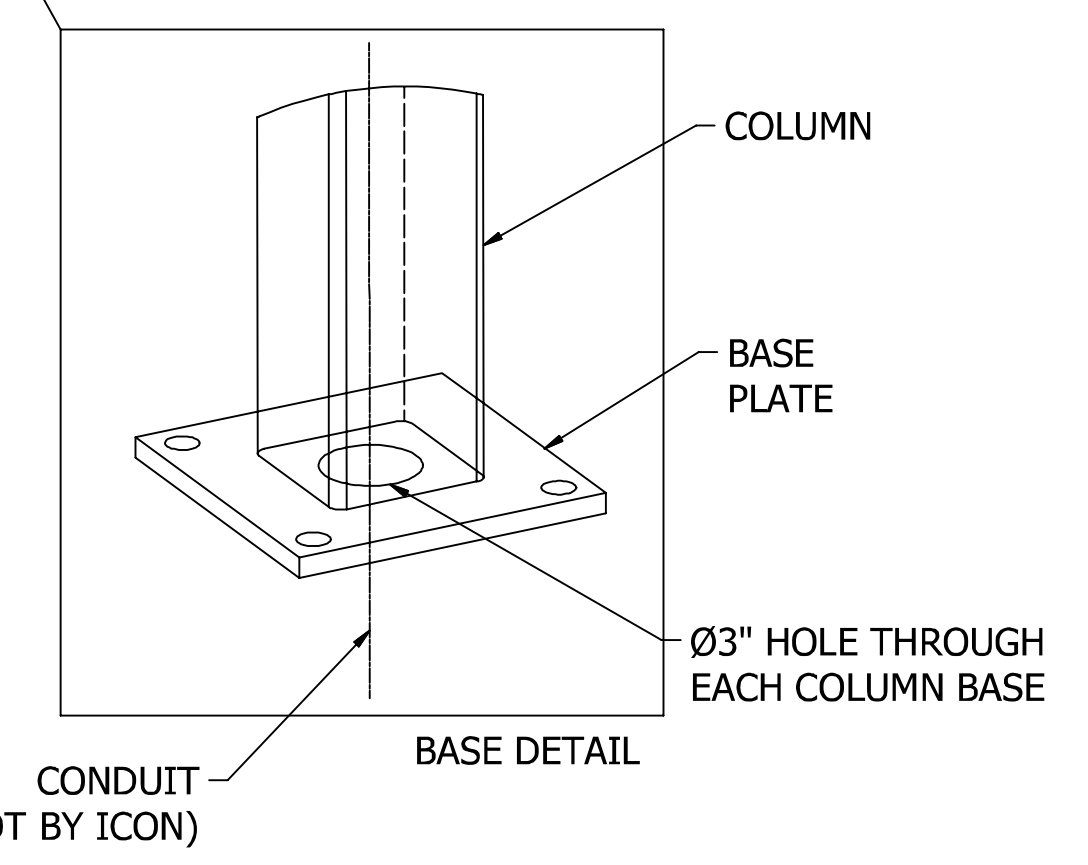

OPTIONAL CUTOUTS
 USE FRAME SHEET OF THIS PRELIMINARY TO SPECIFY REQUIRED CUTOUT LOCATIONS (CHARGES APPLY). SEE REQUIRED INFO BELOW

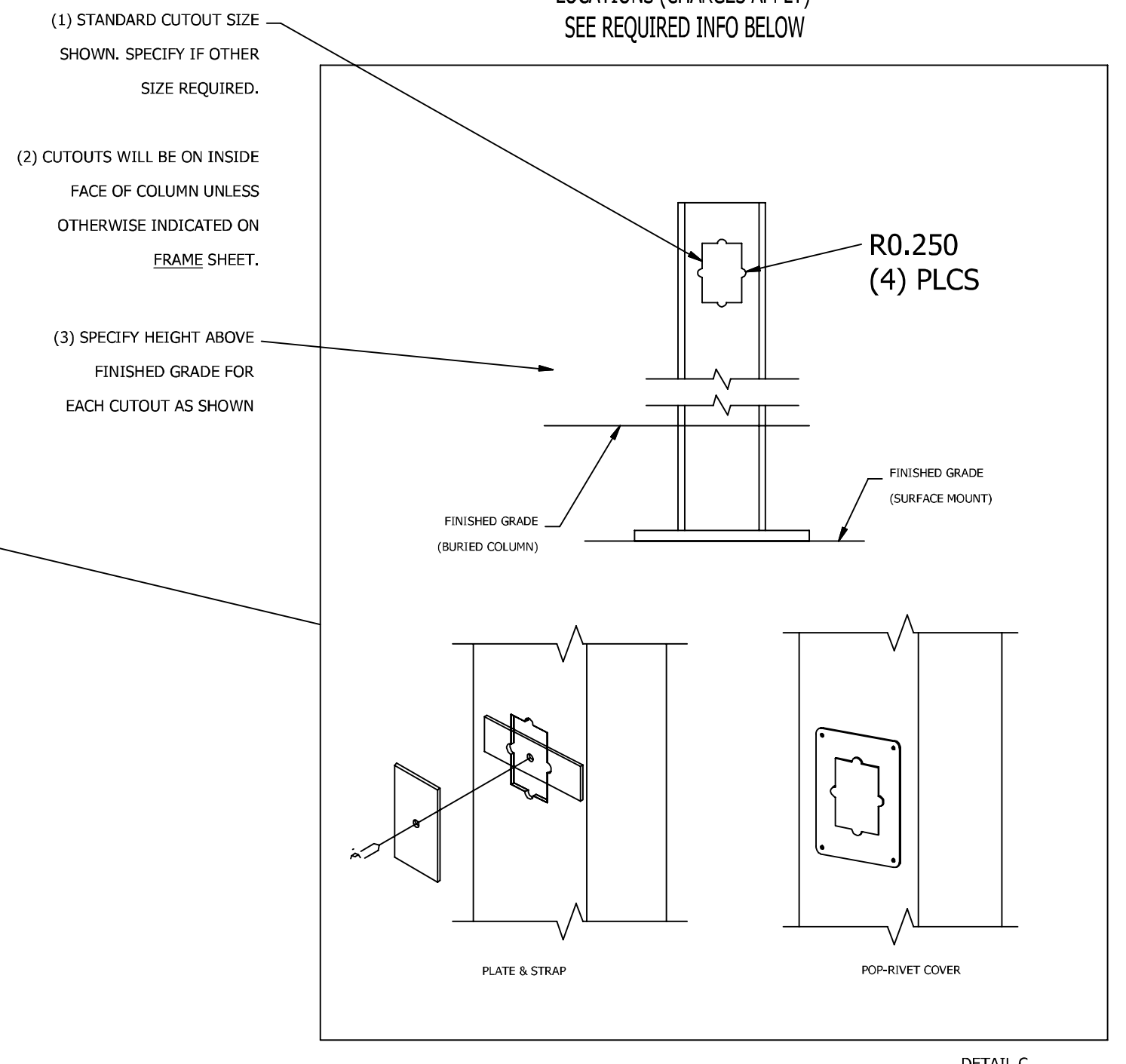

ICON STD	RH/OSA-PC
DRAWN BY	ANGEL
DATE	4/2/2021
REV	
REV DATE	

JRMA
 ARCHITECTS ENGINEERS
 2200 SATORI ST. BERKELEY, CA 94707
 1714 24th STREET #114, SAN DIEGO, CA 92108
 WWW.JRMA.COM

PROFESSIONAL SEAL
 MICHAEL D. JOHNSON
 REGISTERED PROFESSIONAL ARCHITECT
 STATE OF CALIFORNIA
 07/29/2021

~~APPROVED
 DIR. OF THE STATE ARCHITECT
 APP: 04-120013-PC
 REVIEWED FOR
 SS PL ACS CG
 DATE: 08/08/2021~~

ELECTRICAL ACCESS

ICON Shelter Systems Inc
 DISTINCTIVE STEEL SHELTERS
 WWW.ICONSHELTERS.COM
 COPYRIGHT 2004, ICON SHELTER SYSTEMS, INC.
 1455 LINCOLN AVE.
 HOLLAND MI, 49423
 616.396.0919
 800.748.0985
 616.396.0944 FX

LS5.0

PRE-CHECK (PC) DOCUMENT
 Code: 2019 CBC
 A separate project application for construction is required.

PRINTED ON :

SHADE STRUCTURE AT JOHN D. SLOAT ELEMENTARY SCHOOL

SACRAMENTO CITY UNIFIED SCHOOL DISTRICT
 SACRAMENTO, CA

Revision

Copyright © 2021 Rainforth Grau Architects. All rights reserved. Reproduction of these plans, either in whole or in part, including any form of copying and/or preparation of derivative works thereof, for any reason without prior written permission, is strictly prohibited.

ELECTRICAL ACCESS

PROJECT NO. 21-1504.06
 DATE: 4/7/22
 SHEET

LS5.0

AD0.12

ESCUTCHEON COVER, TYP.

3" DIA. WALL MOUNT FLANGE, TYP.
ATTACH TO WALL:
- AT BRICK O/ CONCRETE WALL:
(3) 1/4" DIA. S.S. HILTI KB-TZ2 WEDGE
ANCHORS W/ 3" MIN. EMBEDMENT
INTO CONCRETE

(E) HYDRATION STATION

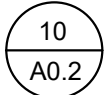

FACE OF WALL (E) WALL

1' - 7" MIN.
1' - 11" MAX.

18 GA. 1 1/2" DIA. STAINLESS
STEEL DRINKING FOUNTAIN GRAB
BAR, BOBRICK MODEL 819298.
ALIGN TO FRONT OF HYDRATION
STATION OR EXTEND PAST
HYDRATION STATION

ESCUTCHEON COVER

3" DIA. FLOOR MOUNT FLANGE.
ATTACH w/ (3) 3/8" DIA S.S. HILTI
KB-TZ2 AND 3" MIN. EMBED INTO
SLAB.

(E) FLOOR FINISH

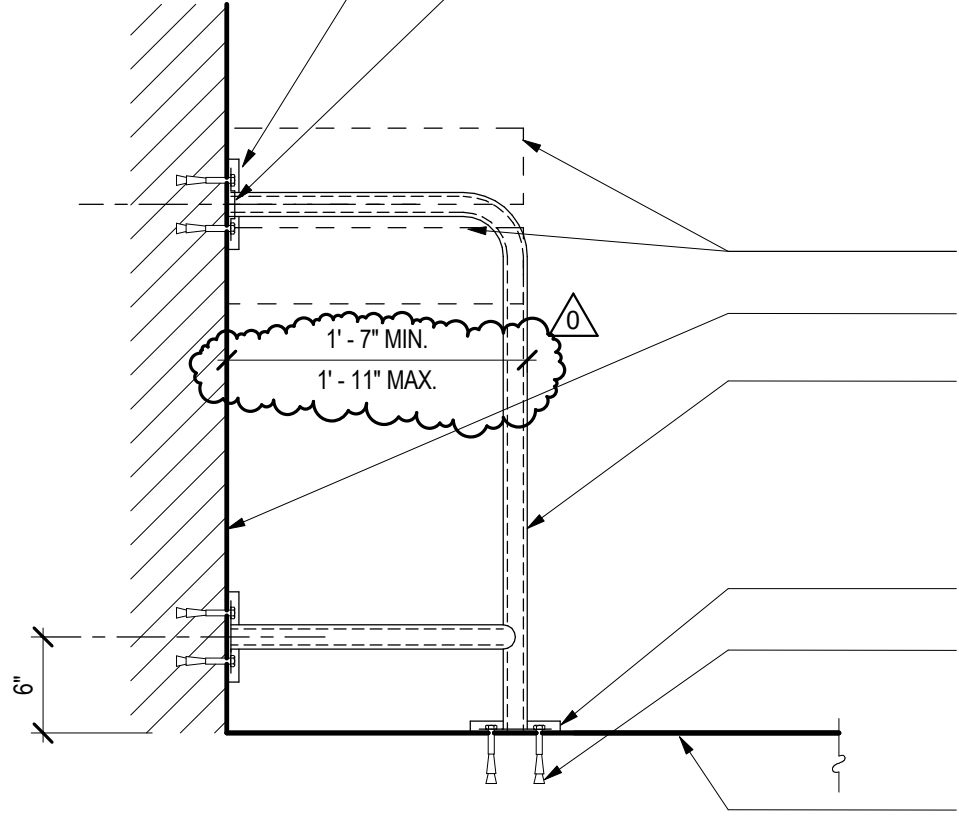

11 HYDRATION STATION GUARDRAIL

1" = 1'-0"



ALL FEATURES, NOTES AND DIMENSIONS NOT SPECIFICALLY SHOWN OR NOTED
AS CHANGED SHALL REMAIN AS SHOWN ON PREVIOUSLY ISSUED DOCUMENTS.

ADDENDUM 0



HYDRATION STATION **A0.2**
SHADE STRUCTURE AT LEATAATA FLOYD
ELEMENTARY SCHOOL
SACRAMENTO CITY UNIFIED SCHOOL DISTRICT
SACRAMENTO, CA
DSA APP.02-119977

DATE: 04/29/22
PROJECT NO.: 21-1504.03
SHEET:
AD0.01

EXISTING TOPOGRAPHY

- = PROPERTY LINE
- = CENTERLINE
- = EASEMENT
- ⊙ = PROPERTY CORNER FOUND AS NOTED
- ⊙ = PROPERTY CORNER NOTHING FOUND OR SET
- ⊙ = TEMPORARY BENCHMARK (SEE TBM LIST FOR INFO)
- = SWALE OR DRAINAGE FLOW
- = DRAINAGE FLOW
- = FENCE (TYPE NOTED)
- ⊙ = TREE (SIZE/TYPE INDICATED)
- = SLOPE
- 100' = CONTOUR
- = CONCRETE SURFACE
- = EDGE OF ASPHALT
- = EDGE OF BUILDING
- = SIGN
- 99.9' = POST OR BOLLARD
- 99.9' = GROUND ELEVATION
- 99.9' = HARD SURFACE ELEVATION

EXISTING UTILITIES

- 12" SD = STORM DRAIN LINE (SIZE & DIRECTION OF FLOW)
- 12" SD = STORM DRAIN LINE (RECORD INFORMATION)
- 12" SD = STORM DRAIN LINE (UNDERGROUND LOCATING)
- ⊙ = STORM DRAIN MANHOLE
- = STORM DRAIN CLEANOUT
- ⊙ = DROP INLET
- ⊙ = AREA DRAIN
- = RAIN WATER LEADER
- DS = DOWNSPOUT
- 12" SS = SANITARY SEWER LINE (SIZE & DIRECTION OF FLOW)
- 12" SS = SANITARY SEWER LINE (RECORD INFORMATION)
- 12" SS = SANITARY SEWER LINE (UNDERGROUND LOCATING)
- ⊙ = SANITARY SEWER MANHOLE
- = SANITARY SEWER CLEANOUT
- W = WATER LINE (SIZE INDICATED)
- W = WATER LINE (RECORD INFORMATION)
- W = WATER LINE (UNDERGROUND LOCATING)
- ⊙ = WATER MANHOLE
- ⊙ = WATER VALVE
- ⊙ = WATER METER
- ⊙ = WATER BOX
- ⊙ = IRRIGATION CONTROL VALVE
- ⊙ = FIRE HYDRANT
- ⊙ = BACKFLOW PREVENTER
- ⊙ = SPRINKLER
- ⊙ = HOSE BIBB
- OH-E = OVERHEAD ELECTRIC LINE
- E = UNDERGROUND ELECTRIC LINE
- E = UNDERGROUND ELECTRIC LINE (RECORD INFORMATION)
- E = UNDERGROUND ELECTRIC LINE (UNDERGROUND LOCATING)
- ⊙ = ELECTRIC MANHOLE
- ⊙ = UTILITY POLE (WITH GUY WIRE)
- ⊙ = ELECTRIC METER
- ⊙ = ELECTRIC BOX
- ⊙ = STREET LIGHTING BOX
- ⊙ OR ⊙ = LIGHT STANDARD
- ⊙ = SIGNAL LIGHT
- ⊙ = FLOOD LIGHT
- ⊙ = ELECTRICAL OUTLET
- G = GAS LINE (SIZE INDICATED)
- G = GAS LINE (RECORD INFORMATION)
- G = GAS LINE (UNDERGROUND LOCATING)
- ⊙ = GAS MANHOLE
- ⊙ = GAS VALVE
- ⊙ = GAS METER
- T = TELEPHONE LINE
- T = TELEPHONE LINE (RECORD INFORMATION)
- T = TELEPHONE LINE (UNDERGROUND LOCATING)
- ⊙ = STORM DRAIN BOX
- ⊙ = TRAFFIC SIGNAL BOX

CIVIL ABBREVIATIONS AND LEGEND

ABBREVIATIONS

- NOTE: NOT ALL ABBREVIATIONS MAY BE USED ON THESE PLANS.
- AB AGGREGATE BASE
 - AC ASPHALTIC CONCRETE
 - AD AREA DRAIN
 - APN ASSESSOR'S PARCEL NUMBER
 - ARV AIR RELEASE VALVE
 - ASB AGGREGATE SUB-BASE
 - BO BLOW-OFF VALVE
 - BV BUTTERFLY VALVE
 - BW BACK OF WALK
 - C/L CENTERLINE
 - CB CATCH BASIN
 - CL CLASS
 - CMP CORRUGATED METAL PIPE
 - CATV CABLE TELEVISION
 - CO CLEANOUT
 - COMM COMMUNICATION
 - CONC. CONCRETE
 - CONSTR. CONSTRUCT
 - CR CURB RETURN
 - CS CONCRETE SURFACE
 - DC DOUBLE CHECK VALVE
 - DDC DOUBLE DETECTOR CHECK VALVE
 - DG DECOMPOSED GRANITE
 - DI DROP INLET
 - DIA DIAMETER
 - DIP DIRECT IRON PIPE
 - DWG DRAWING
 - DS DOWNSPOUT
 - EP ELECTRIC
 - EP EASEMENT
 - ESMT EXISTING
 - EX FIRE SERVICE LINE
 - FL FLOWLINE
 - FL SANITARY SEWER FORCE MAIN
 - FF FINISHED FLOOR ELEVATION
 - FG FIRE HYDRANT
 - GH GRATE ELEVATION
 - GRD GRADE ELEVATION
 - GV GATE VALVE
 - HB HOSE BIBB
 - HBD HEADER BOARD
 - HDPE HIGH DENSITY POLYETHYLENE PIPE
 - HP HIGH POINT
 - INV PIPE INVERT ELEVATION
 - JP JOINT UTILITY POLE
 - LF LINEAL FEET
 - LIP LIP OF GUTTER
 - LT LEFT
 - MS MOWSTRIP
 - NTS NOT TO SCALE
 - OH OVERHEAD
 - PCC PORTLAND CEMENT CONCRETE
 - PD PLANTER DRAIN
 - PIV POST INDICATOR VALVE
 - P/L PROPERTY LINE
 - PP POWER POLE
 - PUE PUBLIC UTILITY EASEMENT
 - PVC POLYVINYL CHLORIDE
 - RCP REINFORCED CONCRETE PIPE
 - R RADIUS
 - RM MANHOLE RIM ELEVATION (SOLID COVER)
 - RP REDUCED PRESSURE BACKFLOW PREVENTER
 - RW RIGHT OF WAY
 - SCH SCHEDULE
 - SD STORM DRAIN
 - SDMH STORM DRAIN MANHOLE
 - SG SUBGRADE ELEVATION
 - SS SANITARY SEWER
 - SSMH SANITARY SEWER MANHOLE
 - STD STANDARD
 - S/W SIDEWALK
 - T TELEPHONE
 - TC TOP OF CURB
 - TD TRENCH DRAIN
 - TDCB TRENCH DRAIN CATCH BASIN
 - TP TELEPHONE POLE
 - TR TOP OF RAMP ELEVATION
 - TRW TOP OF RETAINING WALL
 - TSW TOP OF SEAT WALL
 - TW TOP OF WALK ELEVATION
 - U UTILITY
 - UG UNDERGROUND
 - UON UNLESS OTHERWISE NOTED
 - VCP VITRIFIED CLAY PIPE
 - W WATER
 - W/ WITH
 - W/O WITHOUT
 - WV WATER VALVE

LEGEND

NOTE: NOT ALL SYMBOLS MAY BE USED ON THESE PLANS.

PROPOSED GRADING & DRAINAGE SYMBOLS:

- 8" SD STORM DRAIN LINE (SIZE AND FLOW SHOWN)
- STORM DRAIN MANHOLE (SDMH)
- CATCH BASIN (CB)
- DROP INLET (DI)
- AREA DRAIN (AD)
- PLANTER DRAIN (PD) OR FLOOR DRAIN (FD)
- STORM DRAIN CLEANOUT
- 99.99 ELEVATION
- FF=100.00 FINISHED FLOOR ELEVATION
- PAD=99.33 BUILDING PAD ELEVATION
- CONCRETE SIDEWALK
- GRADED DIRECTION FOR DRAINAGE FLOW
- SWALE
- SLOPE
- ⊙ TREE TO BE REMOVED
- RETAINING WALL

PROPOSED SANITARY SEWER SYMBOLS:

- 6" SS SANITARY SEWER LINE (SIZE AND FLOW SHOWN)
- SANITARY SEWER MANHOLE (SSMH)
- SEWER CLEANOUT FLUSHER BRANCH

PROPOSED WATER SYMBOLS:

- 8" W WATER LINE & SIZE
- 8" FS FIRE LINE & SIZE
- 8" DW DOMESTIC WATER LINE & SIZE
- 8" RW RECLAIMED WATER LINE & SIZE
- 8" IRR IRRIGATION SERVICE LINE & SIZE
- 8" NP NON POTABLE WATER LINE & SIZE
- 8" SP FIRE SPRINKLER SERVICE LINE & SIZE
- GATE VALVE
- WATER METER
- FH FIRE HYDRANT ASSEMBLY
- Y FDC FIRE DEPARTMENT CONNECTION
- DC DETECTOR CHECK VALVE
- DDC DOUBLE DETECTOR CHECK VALVE
- RP REDUCED PRESSURE BACKFLOW PREVENTER
- BUTTERFLY VALVE
- 1" AIR RELEASE VALVE + SIZE
- 1" BLOW-OFF VALVE + SIZE
- PIV POST INDICATOR VALVE

DEMOLITION GENERAL NOTES

- IN THE EVENT THAT ANY UNUSUAL CONDITIONS NOT COVERED BY THE GEOTECHNICAL INVESTIGATION REPORT OR ARE ENCOUNTERED DURING GRADING OPERATIONS THE GEOTECHNICAL ENGINEER AND THE ARCHITECT SHALL BE IMMEDIATELY NOTIFIED FOR DIRECTIONS.
- NO BURNING OR BLASTING SHALL BE PERMITTED.
- ADDITIONAL DEMOLITION INFORMATION MAY BE SHOWN ON THE GRADING, DRAINAGE, AND UTILITY PLANS, AND THOSE PLANS PREPARED BY OTHER DISCIPLINES FOR THIS PROJECT.
- ALL DEMOLISHED ITEMS SHALL BE DISPOSED OF OFFSITE AT A SUITABLE, LEGAL, DUMP SITE OR OTHER FACILITY.
- ALL DISPOSED OF MATERIALS SHALL BE RECYCLED IF POSSIBLE.
- THE TYPES, LOCATIONS, SIZES AND/OR DEPTHS OF EXISTING UNDERGROUND UTILITIES AS SHOWN IN THESE PLANS WERE OBTAINED FROM SOURCES OF VARYING RELIABILITY. THE CONTRACTOR IS CAUTIONED THAT ONLY ACTUAL EXCAVATION WILL REVEAL THE TYPES, EXTENT, SIZES, LOCATIONS, AND DEPTHS OF SUCH UNDERGROUND UTILITIES. A REASONABLE EFFORT HAS BEEN MADE TO LOCATE AND DELINEATE ALL KNOWN UNDERGROUND UTILITIES. HOWEVER, WARREN CONSULTING ENGINEERS CAN ASSUME NO RESPONSIBILITY FOR THE COMPLETENESS OR ACCURACY OF ITS DELINEATION OF SUCH UNDERGROUND UTILITIES, NOR FOR THE EXISTENCE OF OTHER BURIED OBJECTS OR UTILITIES WHICH MAY BE ENCOUNTERED BUT WHICH ARE NOT SHOWN ON THESE PLANS. THE CONTRACTOR OR ANY SUBCONTRACTOR FOR THIS CONTRACT SHALL NOTIFY MEMBERS OF UNDERGROUND SERVICE ALERT (USA) TWO (2) WORKING DAYS IN ADVANCE OF PERFORMING ANY EXCAVATION WORK BY CALLING TOLL FREE 1-800-227-2600, OR 811.
- THE SCHOOL DISTRICT SHALL HAVE SALVAGE RIGHTS TO ANY DEMOLISHED ITEMS SHOWN HEREON. THE CONTRACTOR SHALL GIVE THE DISTRICT NOTICE 7 DAYS PRIOR TO THE START OF DEMOLITION. THE DISTRICT SHALL MOVE ANY RETAINED ITEMS OUT OF THE CONTRACTORS WORK AREA, UNLESS ANOTHER ARRANGEMENT IS MADE WITH THE CONTRACTOR. ANY REMAINING ITEMS BECOME THE PROPERTY OF THE CONTRACTOR AND SHALL BE REMOVED FROM THE SITE. ANY ITEMS NOT SHOWN FOR REMOVAL SHALL REMAIN AND SHALL BE PROTECTED FROM DAMAGE DURING CONSTRUCTION TO A REASONABLE EXTENT.
- EXISTING UTILITY STRUCTURES IN AREAS OF NEW PAVING SHALL BE REMOVED AND REPLACED WITH NEW BOX/COVER AT NEW GRADE UNLESS SPECIFICALLY NOTED OTHERWISE.
- ITEMS OUTSIDE THE LIMITS OF DEMOLITION SHALL REMAIN AND BE PROTECTED FROM DAMAGE DURING CONSTRUCTION.
- EXISTING UTILITY STRUCTURES AND PIPING NOT SHOWN ON DEMOLITION PLAN TO BE REMOVED SHALL REMAIN AND BE PROTECTED.

UTILITY VERIFICATION NOTE

PRIOR TO THE START OF CONSTRUCTION, VERIFY AND POTHOLE ALL UTILITY POINTS OF CONNECTION FOR LOCATION, DEPTH, AND SIZE. IF CONFLICT IS FOUND, CONTACT THE ENGINEER IMMEDIATELY FOR DIRECTION.

IRRIGATION DEMOLITION NOTE

WITHIN LANDSCAPE AREAS TO BE DEMOLISHED THERE MAY BE EXISTING IRRIGATION LINES NOT SHOWN ON THIS PLAN. CONTRACTOR SHALL REMOVE LATERAL LINES AND HEADS ENCOUNTERED. MAIN LINES AND CONTROL WIRES MAY ONLY BE REMOVED PROVIDED THAT ROUTING IS KNOWN AND REMOVAL WILL NOT DEACTIVATE AN IRRIGATION SYSTEMS INTENDED TO REMAIN. IF CONFLICT IS FOUND, CONTACT THE ENGINEER FOR DIRECTION.

GENERAL NOTES

- THE TYPES, LOCATIONS, SIZES, AND/OR DEPTHS OF EXISTING UNDERGROUND UTILITIES AS SHOWN ON THESE PLANS WERE OBTAINED FROM SOURCES OF VARYING RELIABILITY. THE CONTRACTOR IS CAUTIONED THAT ONLY ACTUAL EXCAVATION WILL REVEAL THE TYPES, EXTENT, SIZES, LOCATIONS AND DEPTHS OF SUCH UNDERGROUND UTILITIES. A REASONABLE EFFORT HAS BEEN MADE TO LOCATE AND DELINEATE ALL KNOWN UNDERGROUND UTILITIES. HOWEVER, WARREN CONSULTING ENGINEERS CAN ASSUME NO RESPONSIBILITY FOR THE COMPLETENESS OR ACCURACY OF ITS DELINEATION OF SUCH UNDERGROUND UTILITIES, NOR FOR THE EXISTENCE OF OTHER BURIED OBJECTS OR UTILITIES WHICH MAY BE ENCOUNTERED BUT WHICH ARE NOT SHOWN ON THESE PLANS. THE CONTRACTOR OR ANY SUBCONTRACTOR FOR THIS CONTRACT SHALL NOTIFY MEMBERS OF UNDERGROUND SERVICE ALERT (USA) TWO (2) WORKING DAYS IN ADVANCE OF PERFORMING ANY EXCAVATION WORK BY CALLING TOLL FREE 1-800-227-2600, OR 811.
- WARREN CONSULTING ENGINEERS, INC. (WCE) ASSUMES NO RESPONSIBILITY FOR ERRORS IN PHYSICAL LOCATION OF IMPROVEMENTS, HORIZONTAL OR VERTICAL. IN ADDITION, ANY SUCH ERRORS IN PHYSICAL LOCATION MAY AFFECT THE INTENDED DESIGN OF SUCH IMPROVEMENTS AND WCE CANNOT BE HELD RESPONSIBLE FOR SUCH CONDITIONS WHICH ARE A RESULT OF ERRORS IN SURVEYING, OR IMPROPER CONSTRUCTION.
- IF SUBSURFACE CULTURAL RESOURCES, REMAINS, AND/OR ARTIFACTS ARE UNCOVERED DURING PROJECT CONSTRUCTION, ALL WORK IN THE VICINITY SHALL BE STOPPED UNTIL SUCH ITEMS CAN BE ASSESSED BY AN APPROPRIATE MEMBER OF THE COUNTY ENVIRONMENTAL IMPACT SECTION STAFF.
- CONTRACTOR AGREES THAT HE/SHE SHALL ASSUME SOLE AND COMPLETE RESPONSIBILITY FOR JOB SITE CONDITIONS DURING THE COURSE OF CONSTRUCTION OF THIS PROJECT, INCLUDING SAFETY OF ALL PERSONS AND PROPERTY; THAT THIS REQUIREMENT SHALL APPLY CONTINUOUSLY AND SHALL NOT BE LIMITED TO NORMAL WORKING HOURS; AND THAT THE CONTRACTOR SHALL DEFEND, INDEMNIFY AND HOLD THE OWNER AND ENGINEER HARMLESS FROM ANY AND ALL LIABILITY, REAL OR ALLEGED, IN CONNECTION WITH THE PERFORMANCE OF WORK ON THIS PROJECT, EXCEPTING FOR LIABILITY ARISING FROM THE SOLE NEGLIGENCE OF THE OWNER OR ENGINEER.
- THE CONTRACTOR SHALL OBTAIN AN EXCAVATION PERMIT FROM THE STATE OF CALIFORNIA DEPARTMENT OF INDUSTRIAL SAFETY FOR ALL EXCAVATIONS OF 5 FEET OR MORE IN DEPTH.
- IT SHALL BE THE CONTRACTOR'S RESPONSIBILITY TO MAKE ALL NECESSARY PRE-BID AND PRE-CONSTRUCTION SITE INSPECTION, AND/OR OBSERVATIONS ON THE SITE TO PRE-DETERMINE ALL HIS/HER MEANS AND METHODS NECESSARY TO COMPLETE THE IMPROVEMENTS SHOWN ON THESE PLANS AND PER THE PROJECT SPECIFICATIONS. IT IS THE CONTRACTOR'S RESPONSIBILITY TO DETERMINE, AND INCLUDE IN HIS/HER CONTRACT, ALL MEANS AND METHODS NECESSARY TO PERFORM A COMPLETE AND ACCEPTABLE JOB.
- WHERE IMPROVEMENTS LIE WITHIN AN EXISTING DEVELOPED AREA, CONTRACTOR SHALL USE CAUTION WHEN ACCESSING THE SITE THROUGH THESE EXISTING IMPROVEMENTS. IT IS THE CONTRACTOR'S RESPONSIBILITY TO PROTECT ANY SUCH EXISTING IMPROVEMENTS OUTSIDE THE PROJECT BOUNDARY, OR EXISTING IMPROVEMENTS WITHIN THE BOUNDARY WHICH ARE TO REMAIN. PROPER PRECAUTIONS SHALL BE PROVIDED AND MAINTAINED THROUGHOUT CONSTRUCTION. ANY DAMAGE SHALL BE REPAIRED OR REPLACED TO THE SATISFACTION OF THE OWNER.
- IT IS THE RESPONSIBILITY OF THE CONTRACTOR TO KEEP DETAILED RECORDS OF MINOR CHANGES OR ADJUSTMENTS MADE DURING CONSTRUCTION (WHICH WERE NOT FORMALLY ISSUED). UPON PROJECT COMPLETION, THESE RECORDS AND/OR INFORMATION SHALL BE PROVIDED TO THE OWNER AND WARREN CONSULTING ENGINEERS, INC. UNLESS AN OFFICIAL "AS-BUILT" SET OF PLANS IS A REQUIREMENT OF THE CONTRACT. IF "AS-BUILT" PLANS ARE A REQUIREMENT OF THE CONTRACT, REFER TO SPECIFICATIONS FOR AS-BUILT DELIVERABLE REQUIREMENTS.
- IN VEHICULAR PATHWAYS, EXISTING ASPHALTIC AND/OR CONCRETE SURFACES SHALL BE CUT TO A NEAT AND STRAIGHT LINE, PARALLEL OR PERPENDICULAR TO THE VEHICULAR TRAVELED PATH. THIS IS TYPICALLY THE ROADWAY CENTERLINE, BUT MAY VARY. THAT SAWCUT EDGE SHALL BE PROTECTED FROM DAMAGE DURING CONSTRUCTION SO A CLEAN PATCH BAGS IF PATCH IS DAMAGED. EDGE IS DAMAGED, A NEW SAW CUT WILL BE REQUIRED. THE EXPOSED EDGE SHALL BE "TACKED" WITH EMULSION PRIOR TO PAVING.
- NO BURNING OR BLASTING SHALL BE ALLOWED ONSITE UNLESS SPECIFICALLY ADDRESSED ON PLANS, OR SPECIFICALLY APPROVED AND COORDINATED WITH THE ARCHITECT, ENGINEER, AND LOCAL AGENCY OR OTHER ADMINISTRATIVE AUTHORITY.
- SUBGRADE AND RESULTING FINISHED GRADE SHALL BE CONSTRUCTED SMOOTH AND UNIFORM BETWEEN SPOT ELEVATIONS, CONTOURS OR OTHER STRUCTURE ELEVATIONS SHOWN ON GRADING OR OTHER PLANS. NO MOUNDS, RUTS, DEPRESSIONS OR OTHER GRADING DEFICIENCIES WILL BE ALLOWED UNLESS SPECIFICALLY SHOWN ON PLANS.
- ON NEW WATER SYSTEMS, SERVICE LATERALS SHALL BE MADE USING APPROPRIATE "TEE" AND "WYE" FITTINGS. SADDLE TAPS WILL ONLY BE ALLOWED WHEN MAKING CONNECTIONS TO EXISTING WATER MAINS.
- CURING COMPOUND SHALL BE APPLIED IN A CONTINUOUS SOLID WET FLOWING COAT. ANY "SPOTTY" APPLICATIONS SHALL BE RECOATED IMMEDIATELY. APPLICATION SHALL BE INSPECTED BY PROJECT INSPECTOR DURING APPLICATION.
- EMBEDMENT OF FEATURES IN CONCRETE PAVING, CURBS, OR WALLS, SUCH AS SQUARE OR ROUND TUBING, POSTS, OR COLUMNS, STEEL BOLTED PLATES, OR OTHER STRUCTURES, SHALL REQUIRE ADDITIONAL SCORE OR EXPANSION JOINTS TO PREVENT UNCONTROLLED CRACKING. THOSE ADDITIONAL JOINTS MAY OR MAY NOT BE SPECIFICALLY SHOWN ON PLANS BUT SHALL BE PROVIDED BY THE CONTRACTOR.
- EMBEDMENT OF FEATURES IN CONCRETE PAVING, CURBS, OR WALLS, SUCH AS SQUARE OR ROUND TUBING, POSTS, OR COLUMNS, STEEL BOLTED PLATES, SHALL REQUIRE A MINOR ADJUSTMENT OF REBAR WITHIN CONCRETE TO ALLOW FOR SUCH STRUCTURE. THAT REBAR ADJUSTMENT MAY NOT BE SPECIFICALLY SHOWN ON PLANS.
- NO MORE THAN 1 GALLON OF WATER PER YARD OF CONCRETE CAN BE ADDED TO THE TRUCK AFTER ARRIVAL TO PROJECT SITE. THE ADDITION OF WATER CAN ONLY BE ADDED UNDER THE SUPERVISION OF THE CONCRETE INSPECTOR OR LABORATORY TECHNICIAN.
- WHEN PUMPING CONCRETE FOR PLACEMENT, ABSOLUTELY NO WATER IS TO BE ADDED TO PUMP HOPPER. ANY WATER ADDED TO HOPPER WILL BE REASON FOR CONCRETE REJECTION AT THE CONTRACTORS EXPENSE.
- ALL CONTRACTION/CONSTRUCTION JOINTS "CJ" SHALL BE 1/4 THE SLAB THICKNESS DEEP, BUT NO LESS THAN 1" FOR CONTROLLING OF CRACKING. CONTRACTOR SHALL EXERCISE CAUTION WHEN FINAL TROWELING OF CONCRETE SO AS NOT TO FILL IN THESE JOINTS WITH CONCRETE CREAM. ANY CRACKS OUTSIDE OF JOINTS WHICH WERE CONSTRUCTED LESS THAN 1" DEEP, SHALL BE CAUSE FOR CONCRETE SLAB(S) TO BE REMOVED AND REPLACE AT CONTRACTORS EXPENSE.
- ANY SCORED BOARDS SET WITHIN CONCRETE SLABS SHALL BE AN "OVERHEAD SCREED" SO THERE IS NO INTERFERENCE WITH THE PLACEMENT AND ALIGNMENT OF SLAB REINFORCING.
- 3-1/2" FELT JOINTS WILL NOT BE ACCEPTED. PROVIDE A FULL 4" FELT JOINT FOR 4" SLAB CONSTRUCTION, AND A 6" FELT JOINT FOR A 6" SLAB CONSTRUCTION.
- SHOULD ANY SHRINKAGE CRACKS OCCUR OUTSIDE OF EITHER THE EXPANSION JOINTS OR CRACK CONTROL JOINTS, THEN THE CONCRETE SLAB SHALL BE SAWCUT AT THE NEAREST JOINTS ON EACH SIDE OF THE CRACK AND THE CONCRETE SECTION SHALL BE, REMOVED AND REPLACED. NEW CONCRETE SHALL BE DOWELED INTO EXISTING CONCRETE PER DRAWING DETAIL.
- ALL AREAS DISTURBED BY GRADING OPERATIONS WHETHER SHOWN ON THE DRAWINGS OR NOT SHALL BE HYDRO SEEDDED UNLESS OTHERWISE NOTED. HYDRO SEEDING SHALL CONFORM TO LOCAL CITY/COUNTY STANDARDS.
- REPAIR OR PATCHING OF GALVANIZED METALS, SUCH AS AFTER WELDING GALVANIZED COMPONENTS, SHALL BE MADE USING A ZINC COMPOSITION "HOT STICK" APPLICATION PER ASTM A 780-01. GALVANIZING PAINTS WILL NOT BE ALLOWED.

GENERAL PAVING NOTES:

- PROVIDE EQUIVALENT OF MEDIUM BROOM FINISH AT SLOPES UP TO 5.99%, TYPICAL PROVIDE EQUIVALENT OF HEAVY BROOM FINISH AT SLOPES 6% AND GREATER. REFER TO SPECIFICATIONS.
- ALL NEW PEDESTRIAN WALKWAYS (NON-RAMP) SHALL BE SLOPED NO GREATER THAN 2.0%, AND NO LESS THAN 0.75% ANYWHERE, UNLESS SPECIFICALLY LABELLED OTHERWISE. ALL CONCRETE SHALL MEET THE FOLLOWING SLOPE REQUIREMENTS:
 - NO GREATER THAN 5% SLOPE IN THE DIRECTION OF TRAVEL.
 - NO GREATER THAN 2% SLOPE CROSSING THE DIRECTION OF TRAVEL.
 - NO GREATER THAN 2% SLOPE IN ANY DIRECTION IN COURTYARD OR PLAZA AREAS.

CIVIL SHEET INDEX

- C0.1 CIVIL GENERAL NOTES AND ABBREVIATIONS
- C1.1 DEMOLITION PLAN
- C2.1 GRADING, DRAINAGE AND PAVING PLAN
- C3.1 DETAILS AND SECTIONS

TBM LIST

NUMBER	DESCRIPTION	NORTHING	EASTING	ELEV
2	OPS CHISELED "+"	1964.64	4061.25	14.20
3	OPS CHISELED "+"	1924.19	4040.85	13.72
4	OPS CHISELED "+"	1990.59	3940.07	14.60
7	OPS CHISELED "+"	1555.03	4779.88	10.09
8	CPF BM 297-B6 (EL 9.975)	1422.57	4745.03	9.98
9	OPS CHISELED "+"	2226.11	4193.28	14.69
20	OPS CHISELED "+"	2134.51	4150.91	15.58
21	OPS CHISELED "+"	2234.35	4104.52	16.30
22	OPS CHISELED "+"	2182.00	4030.01	16.35
23	OPS CHISELED "+"	2277.35	3980.80	16.32
24	OPS CHISELED "+"	2356.08	3993.18	16.12
25	OPS CHISELED "+"	2393.99	3819.93	16.34
26	OPS CHISELED "+"	2425.15	4004.06	16.25
27	OPS CHISELED "+"	2510.85	4017.50	16.16
28	OPS CHISELED "+"	2578.48	4044.95	16.12

A.P.N.	009-0030-058
BENCHMARK NO.	297-B6A ELEV. 9.975
HILT NAIL LIGHT BASE NW CORNER 5TH ST. AND SEAVEY CIRCLE.	

LANDSCAPE/IRRIGATION NOTE:
GENERAL CONTRACTOR IS REQUIRED TO HIRE A LANDSCAPE SUBCONTRACTOR TO PERFORM ALL LANDSCAPE AND IRRIGATION REPAIRS.

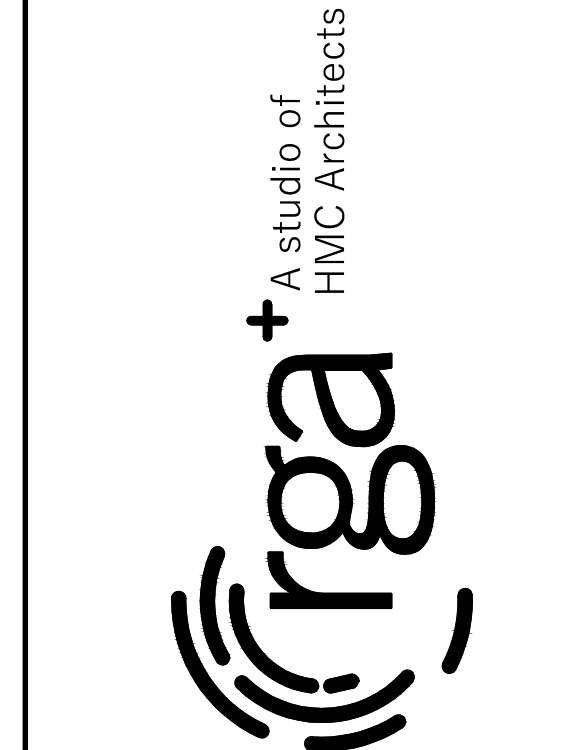

SHADE STRUCTURE AT LEATAATA FLOYD ELEMENTARY SCHOOL
SACRAMENTO CITY UNIFIED SCHOOL DISTRICT
SACRAMENTO, CA

Copyright © 2021 Rainforth Grau Architects. All rights reserved. Reproduction of these plans, either in whole or in part, including any form of copying and/or preparation of derivative works thereof, for any reason without prior written permission, is strictly prohibited.

CIVIL GENERAL NOTES AND ABBREVIATIONS

PROJECT NO. 21-1504.03
DATE: 04/29/22
SHEET **C0.1**

Statement of General Conformance

THE FOLLOWING DRAWINGS OR SHEETS LISTED ON THE COVER OR INDEX SHEET HAVE BEEN PREPARED BY OTHER DESIGN PROFESSIONALS OR CONSULTANTS WHO ARE LICENSED AND/OR AUTHORIZED TO PREPARE SUCH DRAWINGS IN THIS STATE. IT HAS BEEN EXAMINED BY ME FOR:

- 1) DESIGN INTENT AND APPEARS TO MEET THE APPROPRIATE REQUIREMENTS OF TITLE 24, CALIFORNIA CODE OF REGULATIONS AND THE PROJECT SPECIFICATIONS PREPARED BY ME, AND
- 2) COORDINATION WITH MY PLANS AND SPECIFICATIONS AND IS ACCEPTABLE FOR INCORPORATION INTO THE CONSTRUCTION OF THIS PROJECT.

THE STATEMENT OF GENERAL CONFORMANCE "SHALL NOT BE CONSTRUED AS RELIEVING ME OF MY RIGHTS, DUTIES, AND RESPONSIBILITIES UNDER SECTIONS 17302 AND 81138 OF THE EDUCATION CODE AND SECTIONS 4-336, 4-341, AND 4-344" OF TITLE 24, PART 1. (TITLE 24, PART 1, SECTION 4-317 (b))



SIGNATURE

4/21/22

DATE

ARCHITECT OR ENGINEER DESIGNATED TO BE IN GENERAL RESPONSIBLE CHARGE

Jeffrey Grau

PRINT NAME

C-14648 05/31/23

LICENSE NUMBER EXPIRATION DATE

LIST COMPLETELY, ITEMS REVIEWED AND ACCEPTED:

PC SHADE STRUCTURE

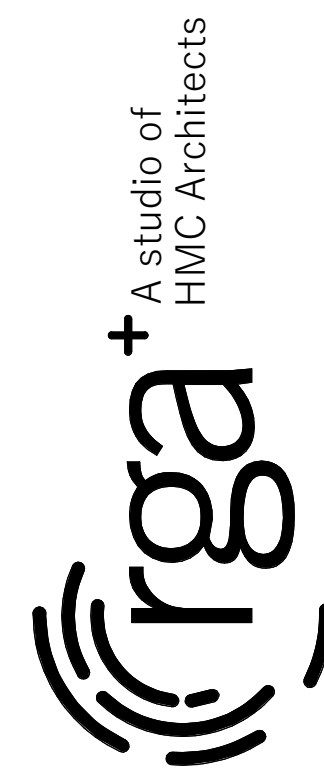
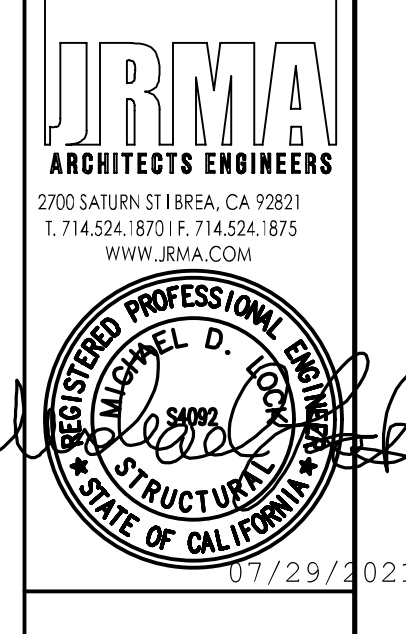
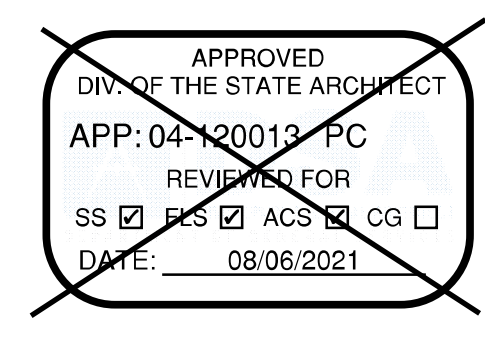

Table with columns: ICON STD, R4/DSA-PC, DRAWN BY, DATE, REV, REV DATE



04/29/2021



DESIGN CRITERIA table with columns: DESCRIPTION, DESIGN VALUES. Includes sections for DEAD AND LIVE LOADS, WIND DESIGN, SEISMIC DESIGN, and FOUNDATIONS.

GENERAL notes and specifications. Includes sections for GENERAL, WELDING, BOLTING, REINFORCING STEEL, FOUNDATIONS, and STRUCTURAL AND MISCELLANEOUS STEEL.

GENERAL notes and specifications. Includes sections for FOUNDATIONS, STRUCTURAL AND MISCELLANEOUS STEEL, and CONCRETE.

REINFORCING STEEL table with columns: DESCRIPTION, DESIGN VALUES. Includes sections for WIND DESIGN, RISK CATEGORY, EXPOSURE CATEGORY, SEISMIC DESIGN, and SEISMIC SITE CLASS.

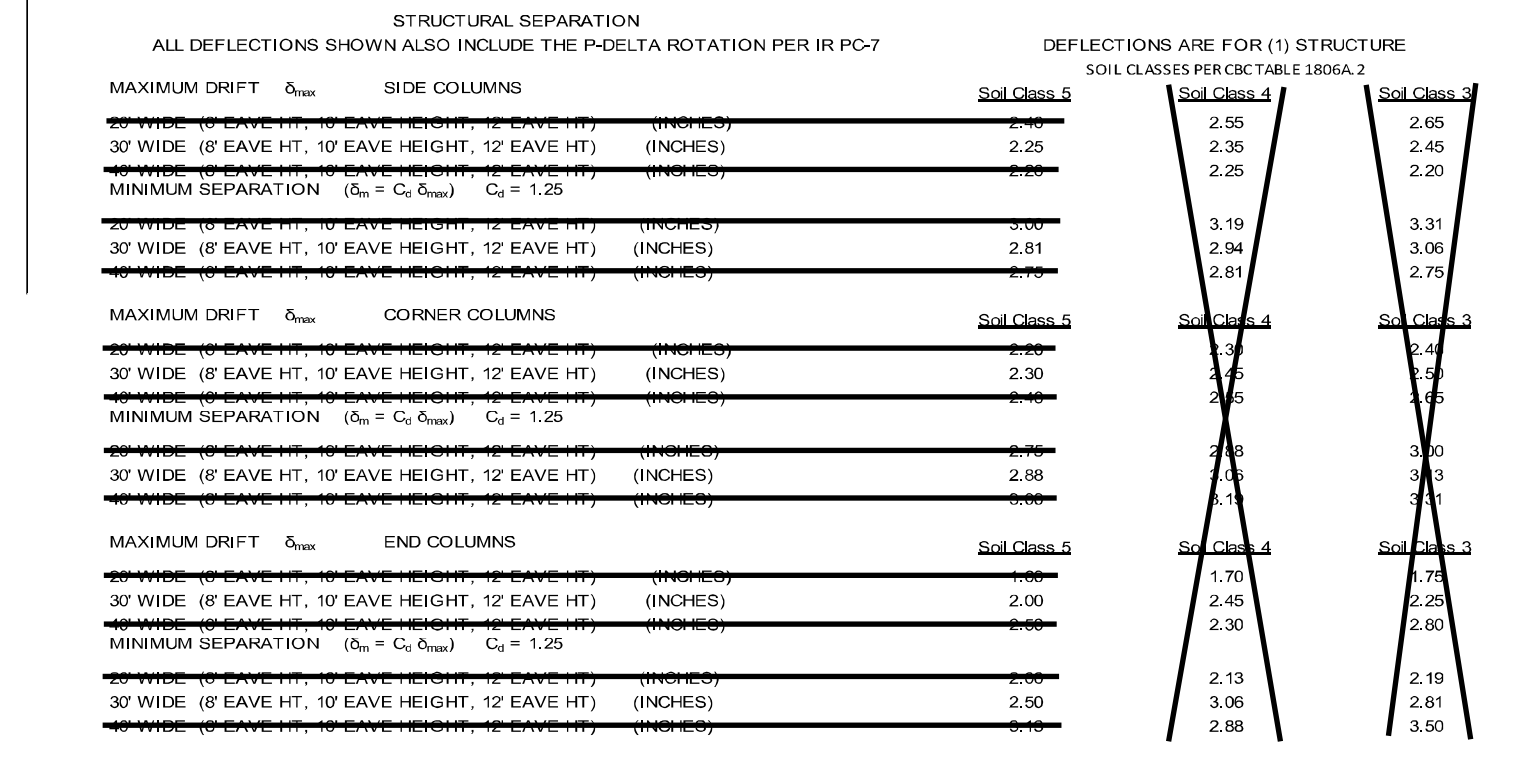

INSTRUCTIONS FOR ARCHITECTS SUBMITTING THESE PRE-CHECKED DRAWING TO DSA. Includes steps 1 through 10 regarding project name, frame dimensions, roof panel, and foundation requirements.

CONCRETE table with columns: STRENGTH FC (28 DAYS), W/C RATIO, W/C RATIO (AIR ENTRAINED), SLUMP (in), UNIT WEIGHT (NORMAL WEIGHT). Includes a table for CONCRETE MIX DESIGN PARAMETERS.

FOUNDATION REQUIREMENTS table with columns: SOIL CLASS, BEARING, PSF. Includes a table for MISCELLANEOUS and SHEET INDEX.

ARCHITECTURAL REQUIREMENTS table with columns: DESCRIPTION, DESIGN VALUES. Includes sections for TYPE OF CONSTRUCTION, OCCUPANCY CLASSIFICATION, NUMBER OF STORES, and FIRE SPRINKLER SYSTEM.

ROOF PANEL table with columns: DESCRIPTION, DESIGN VALUES. Includes sections for SOIL REGION, SOIL REGIONS, MAX DEAD LOAD, and SOIL CLASS.

DESCRIPTION table with columns: DESCRIPTION, DESIGN VALUES. Includes sections for TOTAL ROOF DEAD LOAD, DEAD LOAD, and EXAMPLES.

DESIGN CRITERIA FOR 401 MCCLATCHY WAY, SACRAMENTO, CA 95818 table with columns: DESCRIPTION, DESIGN VALUES. Includes sections for WIND DESIGN, RISK CATEGORY, EXPOSURE CATEGORY, SEISMIC DESIGN, and SEISMIC SITE CLASS.

RELATED BUILDING CODES AND STANDARDS. Lists various California codes including Administrative Code (CAC), Building Code (CBC), Electrical Code, Mechanical Code (CMC), Plumbing Code (CPC), Energy Code, Fire Code (FCF), Green Building Standards Code, and Reference Code Sections for Applicable Standards.

NOTICE OF DISCLAIMER FOR STRUCTURAL ENGINEERING RESPONSIBILITY. States that the design professional is not responsible for the design of the structure, only for the design of the structural steel members.

CONSTRUCTION NOTES. Lists instructions for the contractor regarding steel fabrication, welding, bolting, and concrete placement.

GENERAL INFO table with columns: DESCRIPTION, DESIGN VALUES. Includes sections for WIND DESIGN, RISK CATEGORY, EXPOSURE CATEGORY, SEISMIC DESIGN, and SEISMIC SITE CLASS.

GENERAL INFO text including project name, location, and contact information for KCON Shelter Systems Inc.

SHADE STRUCTURE AT LEATAATA FLOYD ELEMENTARY SCHOOL. SACRAMENTO CITY UNIFIED SCHOOL DISTRICT. SACRAMENTO, CA.

Revision table with columns: Revision, Description. Includes a section for GENERAL INFO with project number, date, and sheet information.

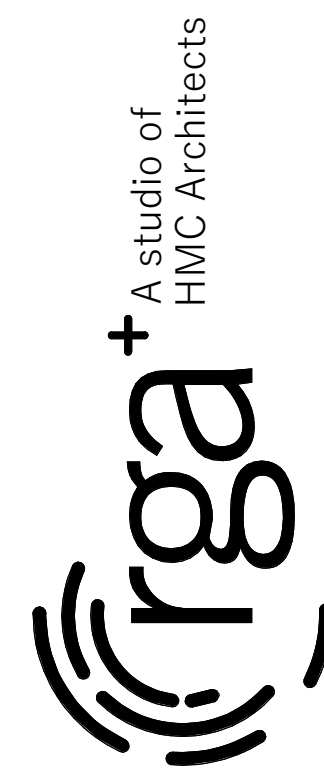

ICON STD: RH/DSA-PC
DRAWN BY: ANGEL
DATE: 4/2/2021
REV
REV DATE

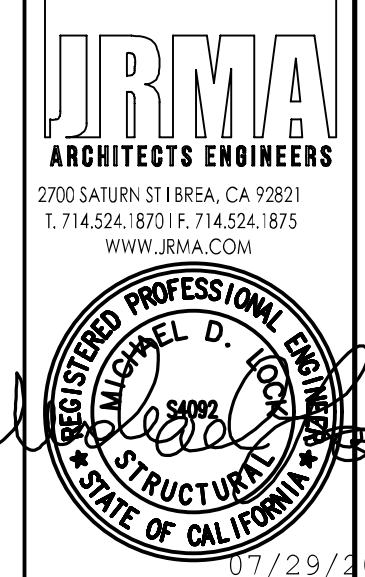

APPROVED DIV. OF THE STATE ARCHITECT APP: 04-190019-PC REVIEWED FOR SS BY FLS D ACS BY CG DATE: 08/06/2021

DSA 103

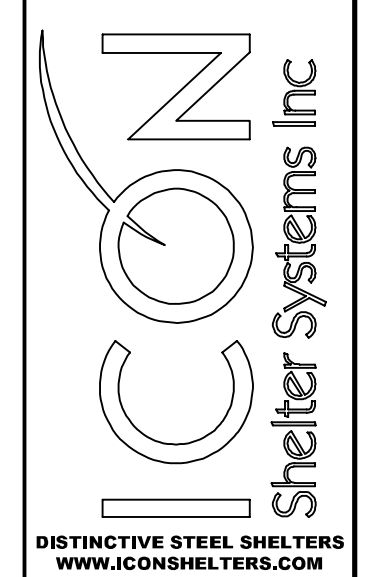

1455 LINCOLN AVE HOLLAND MI, 49423
616.396.0919
800.748.0985
616.396.0944 FX

LS1.1

PRE-CHECK (PC) DOCUMENT Code: 2019 CBC A separate project application for construction is required.

PRINTED ON:

SHADE STRUCTURE AT LEATAATA FLOYD ELEMENTARY SCHOOL

SACRAMENTO CITY UNIFIED SCHOOL DISTRICT SACRAMENTO, CA

Revision

Copyright © 2021 Rainforth Grau Architects. All rights reserved. Reproduction of these plans, either in whole or in part, including any form of copying and/or preparation of derivative works thereof, for any reason without prior written permission, is strictly prohibited.

DSA 103

PROJECT NO. 21-1504.03
DATE: 4/7/22
SHEET

LS1.1

AD0.05

DSA 103-19: LISTING OF STRUCTURAL TESTS & SPECIAL INSPECTIONS (SOILS), 2019 CBC. Application Number: 04-00000, School Name: ICON Shelter Systems, School District: PC, Submittal Date Created: 2021-07-14 05:50:33. Includes tables for Retaining Walls and Other Soil tests.

DSA 103-19: LISTING OF STRUCTURAL TESTS & SPECIAL INSPECTIONS (SOILS), 2019 CBC. Application Number: 04-00000, School Name: ICON Shelter Systems, School District: PC, Submittal Date Created: 2021-07-14 05:50:33. Includes tables for Cast-in-Place Deep Foundations (Piers) and Soil Compaction and Fill tests.

DSA 103-19: LISTING OF STRUCTURAL TESTS & SPECIAL INSPECTIONS (SOILS), 2019 CBC. Application Number: 04-00000, School Name: ICON Shelter Systems, School District: PC, Submittal Date Created: 2021-07-14 05:50:33. Includes Geotechnical Reports section.

DSA 103-19: LISTING OF STRUCTURAL TESTS & SPECIAL INSPECTIONS, 2019 CBC. Application Number: 04-00000, School Name: ICON Shelter Systems, School District: PC, Submittal Date Created: 2021-07-14 05:50:33. Includes Key to Columns section.

DSA 103-19: LISTING OF STRUCTURAL TESTS & SPECIAL INSPECTIONS (Concrete), 2019 CBC. Application Number: 04-00000, School Name: ICON Shelter Systems, School District: PC, Submittal Date Created: 2021-07-14 05:50:33. Includes tables for Cast-in-Place Concrete and Shop Welding tests.

DSA 103-19: LISTING OF STRUCTURAL TESTS & SPECIAL INSPECTIONS (Concrete), 2019 CBC. Application Number: 04-00000, School Name: ICON Shelter Systems, School District: PC, Submittal Date Created: 2021-07-14 05:50:33. Includes tables for High-Strength Bolts and Welds tests.

DSA 103-19: LISTING OF STRUCTURAL TESTS & SPECIAL INSPECTIONS (Concrete), 2019 CBC. Application Number: 04-00000, School Name: ICON Shelter Systems, School District: PC, Submittal Date Created: 2021-07-14 05:50:33. Includes tables for High-Strength Bolts and Welds tests.

DSA 103-19: LISTING OF STRUCTURAL TESTS & SPECIAL INSPECTIONS (Concrete), 2019 CBC. Application Number: 04-00000, School Name: ICON Shelter Systems, School District: PC, Submittal Date Created: 2021-07-14 05:50:33. Includes tables for Cast-in-Place Concrete and Shop Welding tests.

DSA 103-19: LIST OF REQUIRED VERIFIED REPORTS, CBC 2019. Application Number: 04-00000, School Name: ICON Shelter Systems, School District: PC, Submittal Date Created: 2021-07-14 05:50:33. Lists required reports for Soils, Structural Testing, Shop Welding, and High-Strength Bolt Installation.

FOR ALL TESTING AND INSPECTION ITEMS SEE THE DSA APPROVED 103 FOR THIS PROJECT.

DSA STAMP

DSA 103-19: LISTING OF STRUCTURAL TESTS & SPECIAL INSPECTIONS (Steel and Aluminum), 2019 CBC. Application Number: 04-00000, School Name: ICON Shelter Systems, School District: PC, Submittal Date Created: 2021-07-14 05:50:33. Includes tables for Anchor Bolts and Anchor Rods tests.

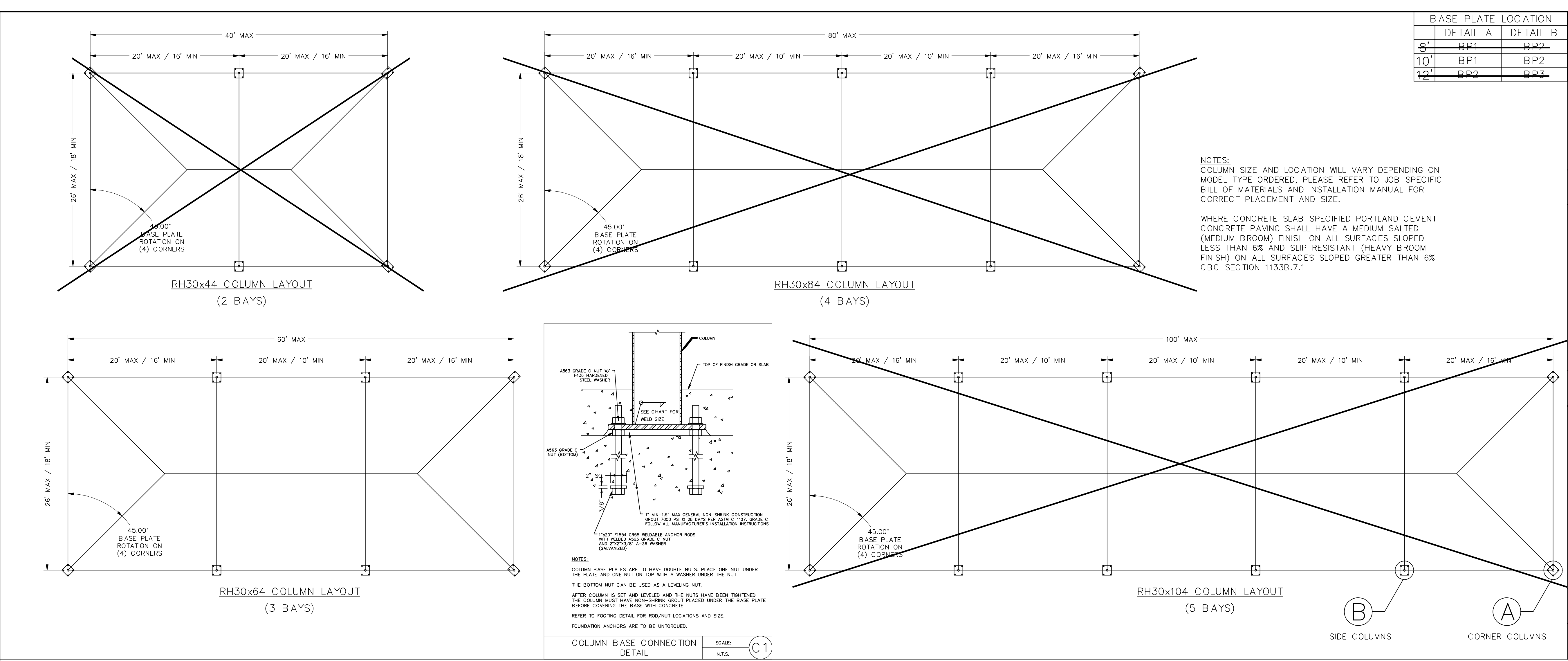

BASE PLATE LOCATION	
DETAIL A	DETAIL B
8'	BP1
10'	BP1
12'	BP2

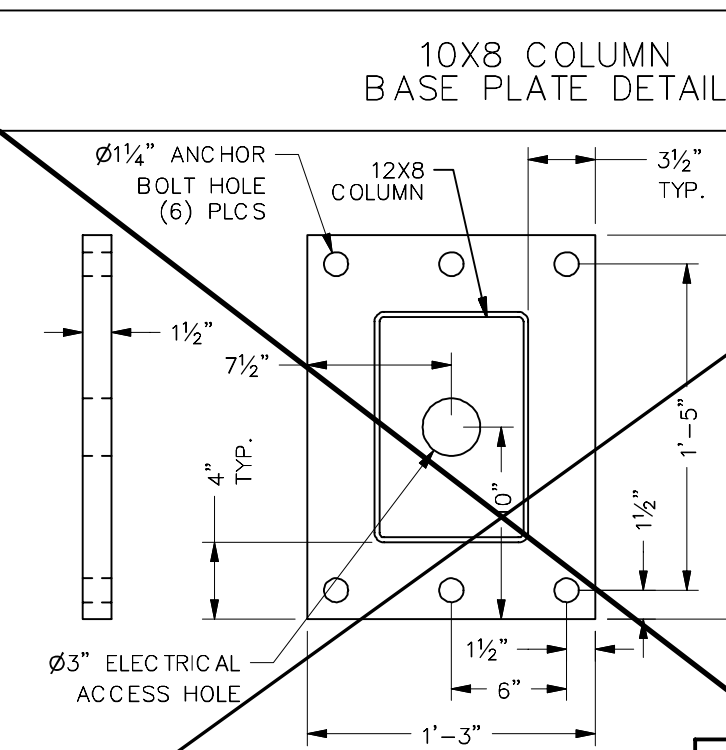
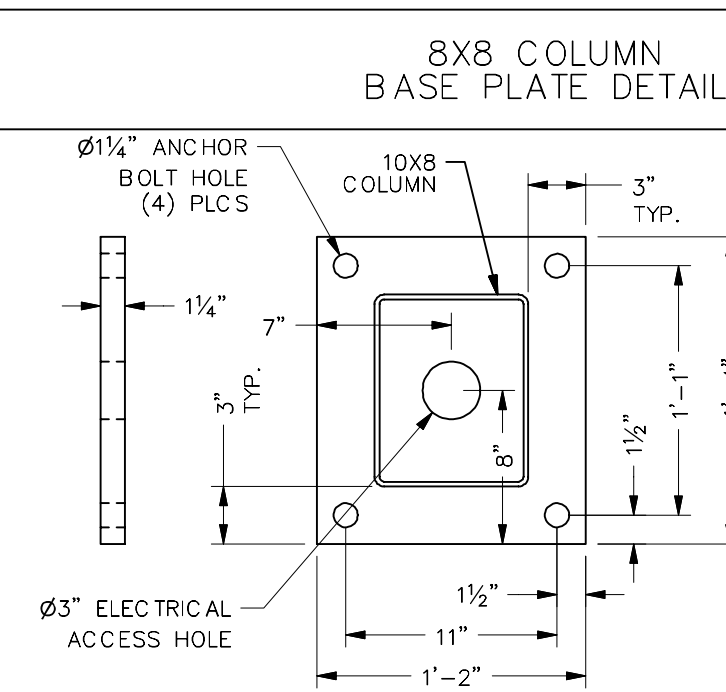
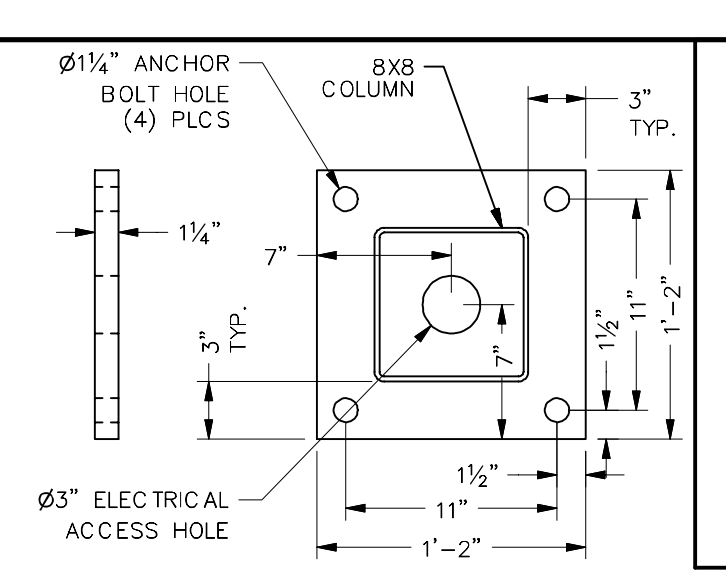

NOTES:
COLUMN SIZE AND LOCATION WILL VARY DEPENDING ON MODEL TYPE ORDERED. PLEASE REFER TO JOB SPECIFIC BILL OF MATERIALS AND INSTALLATION MANUAL FOR CORRECT PLACEMENT AND SIZE.

WHERE CONCRETE SLAB SPECIFIED PORTLAND CEMENT CONCRETE PAVING SHALL HAVE A MEDIUM SALTED (MEDIUM BROOM) FINISH ON ALL SURFACES SLOPED LESS THAN 6% AND SLIP RESISTANT (HEAVY BROOM FINISH) ON ALL SURFACES SLOPED GREATER THAN 6% CBC SECTION 1133B.7.1

ICON STD 84/05A-PC
DRAWN BY: ANGEL
DATE: 4/2/2021
REV: _____
REV DATE: _____

JRMA ARCHITECTS ENGINEERS
2202 SUTHER ST. BERKELEY, CA 94707
1714 24th St #117, Oakland, CA 94612
WWW.JRMA.COM

PROFESSIONAL SEAL
JAMES R. MANNING
REGISTERED PROFESSIONAL ARCHITECT
STATE OF CALIFORNIA
1/29/2021

APPROVED
DIV. OF THE STATE ARCHITECT
APP: 04-20013-PC
REVISED FOR
SS 88 PLS ACS CG
DATE: 08/06/2021

30' WIDE RECTANGULAR HIP

RH30 - PIER				8' height - Corner Columns				8' height - Corner Columns				8' height - Corner Columns				8' height - Corner Columns				
Soil Class 5 - 1500 psf Bearing				Soil Class 4 - 2000 psf Bearing				Soil Class 3 - 3000 psf Bearing				Soil Class 3 - 3000 psf Bearing				Soil Class 3 - 3000 psf Bearing				
Size (A)	Depth (B)	Rebar Qty	Rebar Size	Vertical	Rebar Qty	Rebar Size	Weld	Vertical	Rebar Qty	Rebar Size	Weld	Vertical	Rebar Qty	Rebar Size	Weld	Vertical	Rebar Qty	Rebar Size	Weld	
24	114	6	6	6	24	98	6	6	24	88	6	6	24	88	6	6	24	88	6	6
36	144	12	6	6	30	132	6	6	30	118	6	6	30	118	6	6	30	118	6	6

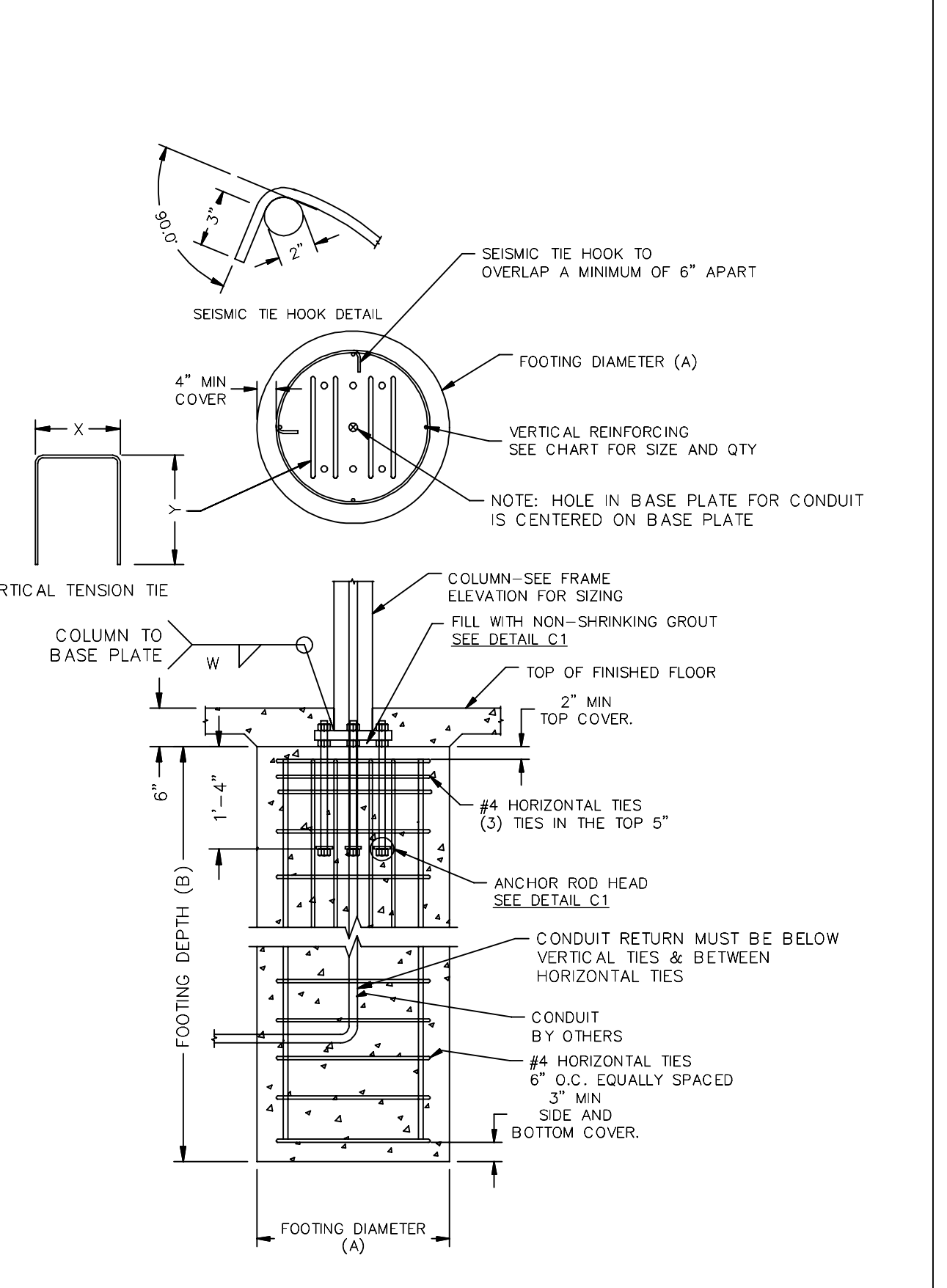

RH30 - SPREAD				8' height - Corner Columns				8' height - Corner Columns				8' height - Corner Columns				8' height - Corner Columns			
Soil Class 5 - 1500 psf Bearing				Soil Class 4 - 2000 psf Bearing				Soil Class 3 - 3000 psf Bearing				Soil Class 3 - 3000 psf Bearing				Soil Class 3 - 3000 psf Bearing			
Size (A)	Depth (B)	Rebar Qty	Rebar Size	Vertical	Rebar Qty	Rebar Size	Weld	Vertical	Rebar Qty	Rebar Size	Weld	Vertical	Rebar Qty	Rebar Size	Weld	Vertical	Rebar Qty	Rebar Size	Weld
60	30	6	6	6	56	30	4	6	54	30	4	6	14	20	15.9	17.3	5	1/4	1/4
80	30	5	6	6	72	30	5	6	68	30	5	6	16	20	15.6	19.3	5	1/4	1/4
66	30	5	6	6	60	30	4	6	57	30	4	6	14	20	15.9	17.3	5	1/4	1/4
81	30	5	6	6	72	30	5	6	69	30	5	6	16	20	15.6	19.3	5	1/4	1/4
78	30	5	6	6	72	30	5	6	72	30	5	6	16	20	15.6	19.3	5	5/16	5/16
64	30	6	6	6	75	30	5	6	75	30	5	6	20	20	16.6	21.3	5	1/4	1/4

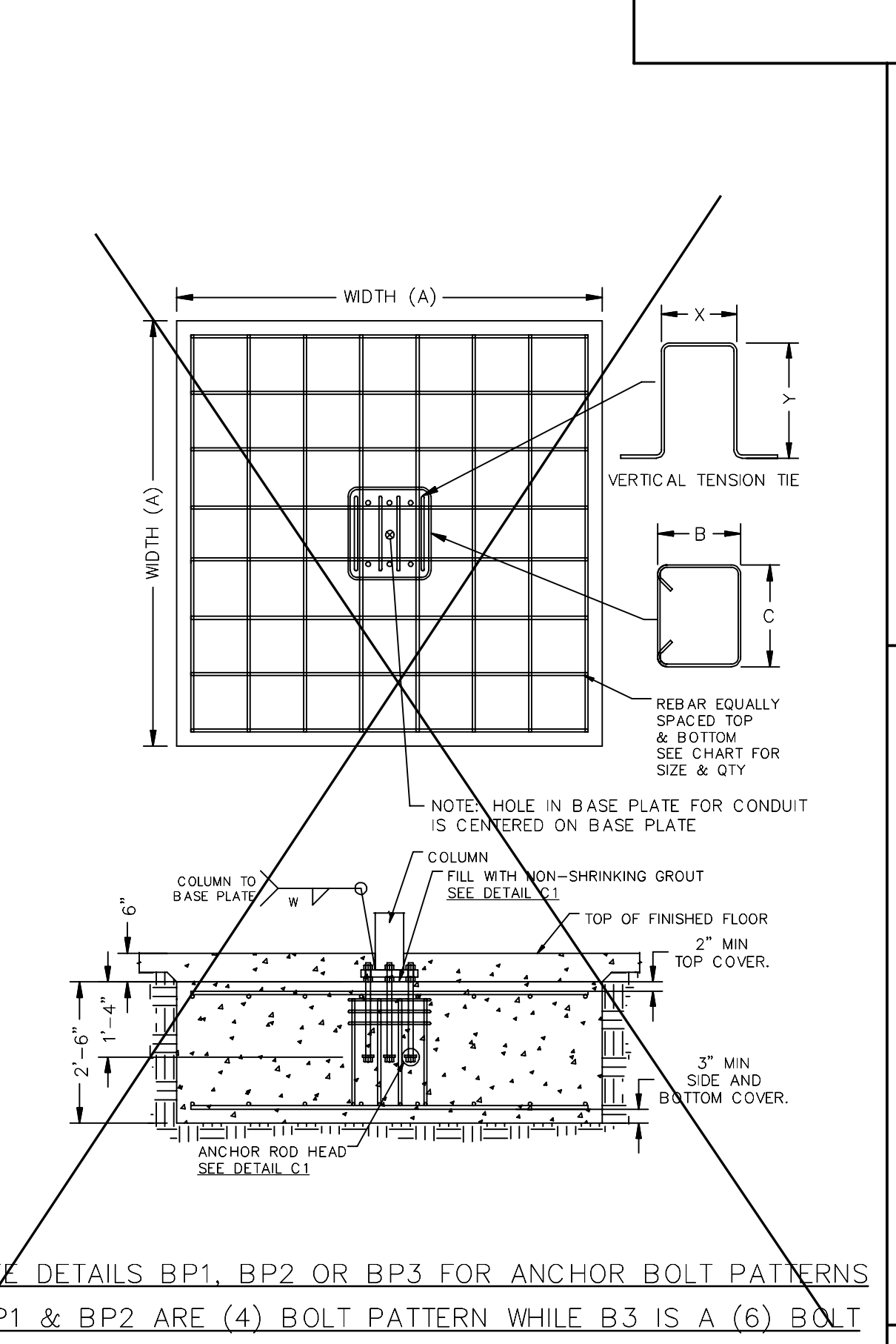

30' WIDE RECTANGULAR HIP FOUNDATION PLAN

ICON Shelter Systems Inc
1455 LINCOLN AVE HOLLAND MI, 49423
616.396.0919
800.748.0985
616.396.0944 FX

PRE-CHECK (PC) DOCUMENT
Code: 2019 CBC
A separate project application for construction is required.

LS3.0

SHADE STRUCTURE AT LEATAATA FLOYD ELEMENTARY SCHOOL
SACRAMENTO CITY UNIFIED SCHOOL DISTRICT
SACRAMENTO, CA

Revision

30' WIDE RECTANGULAR HIP FOUNDATION PLAN

Copyright © 2021 Rainforth Grau Architects. All rights reserved. Reproduction of these plans, either in whole or in part, including any form of copying and/or preparation of derivative works thereof, for any reason without prior written permission, is strictly prohibited.

30' WIDE RECTANGULAR HIP FOUNDATION PLAN

PROJECT NO. 21-1504.03
DATE: 4/17/21
SHEET LS3.0
AD00.06

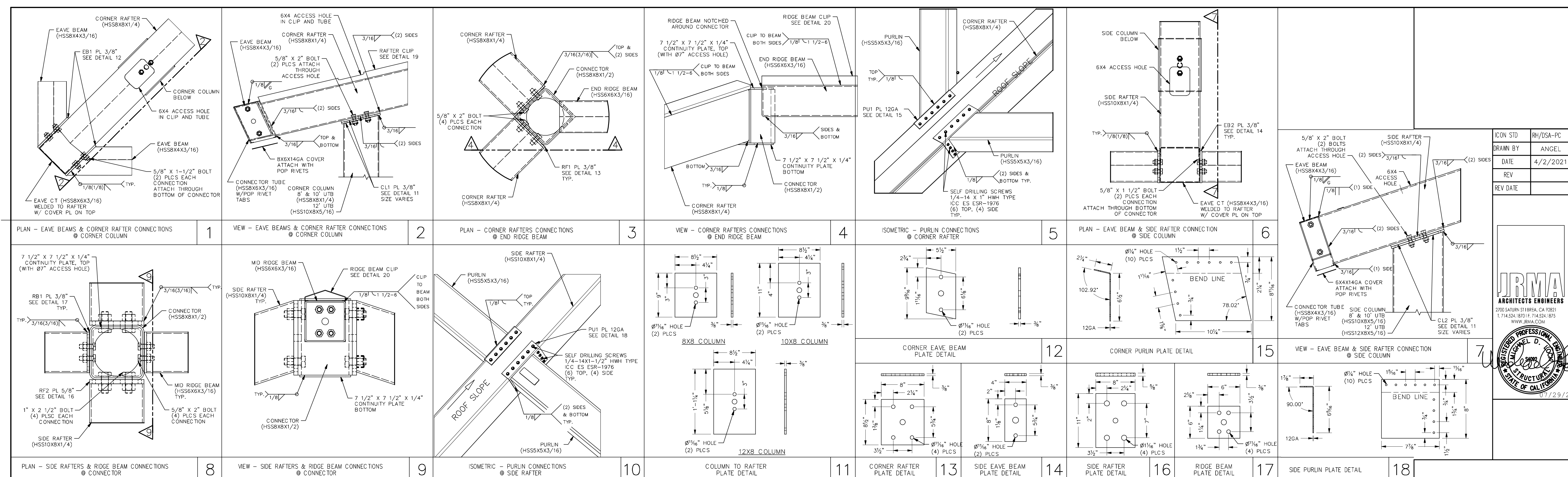

ICON STD	RH/USA-PC
DRAWN BY	ANGEL
DATE	4/2/2021
REV	
REV DATE	

JRMA
ARCHITECTS ENGINEERS
202540911188A, CA 92521
1714524, 8731 F, 714.524.4875
WWW.JRMA.COM



APPROVED
DIV. OF THE STATE ARCHITECT
APP: 04-19077-PC
REVIEW FOR
SS [] PS [] ACS [] CG []
DATE: 08/06/2021

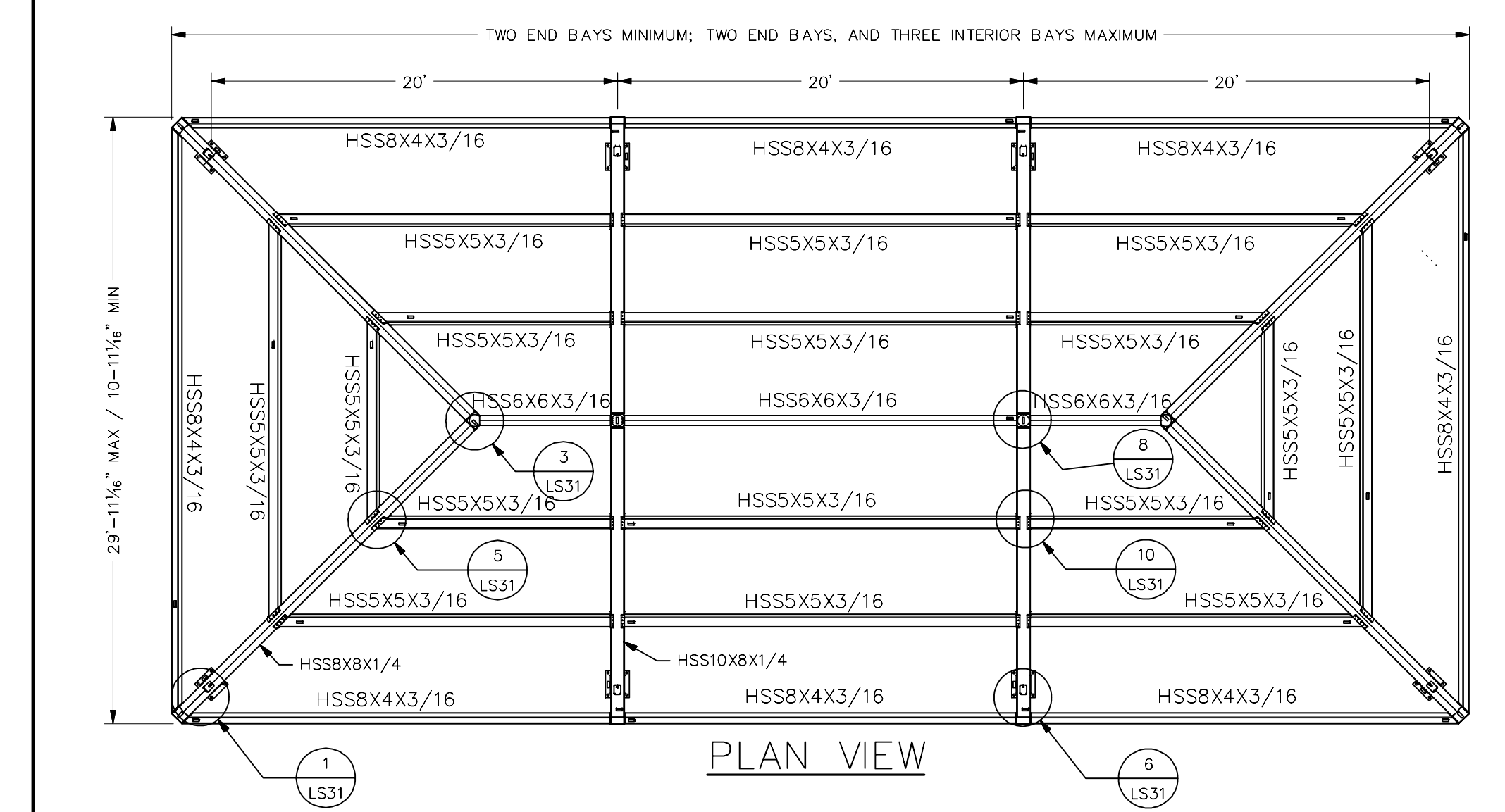

**NOTE:
QUANTITIES WILL VARY DEPENDING ON SHELTER SIZE ORDERED, PLEASE
REFER TO JOB SPECIFIC BILL OF MATERIALS AND INSTALLATION MANUAL.

ITEM	QTY	PART NUMBER	DESCRIPTION	MATERIAL	LENGTH	UNIT WEIGHT
1	4		CORNER COLUMN	**SEE NOTE BELOW		353 lbmass
2	*		SIDE COLUMN	**SEE NOTE BELOW		399 lbmass
3	2		LH SIDE EAVE BEAM	HSS8X4X3/16		311 lbmass
4	2		RH SIDE EAVE BEAM	HSS8X4X3/16		311 lbmass
5	2		END EAVE BEAM	HSS8X4X3/16		422 lbmass
6	*		SIDE EAVE BEAM	HSS8X4X3/16		287 lbmass
7	4		CORNER RAFTER	HSS8X8X1/4		607 lbmass
8	*		SIDE RAFTER	HSS10X8X1/4		474 lbmass
9	2		END RIDGE BEAM	HSS8X6X3/16		149 lbmass
10	*		MID RIDGE BEAM	HSS8X6X3/16		328 lbmass
11	*		CONNECTOR	HSS8X8X1/2		48 lbmass
12	2		LH SIDE PURLIN 1	HSS5X5X3/16		238 lbmass
13	2		RH SIDE PURLIN 1	HSS5X5X3/16		238 lbmass
14	2		END PURLIN 1	HSS5X5X3/16		278 lbmass
15	2		LH SIDE PURLIN 2	HSS5X5X3/16		167 lbmass
16	2		RH SIDE PURLIN 2	HSS5X5X3/16		167 lbmass
17	2		END PURLIN 2	HSS5X5X3/16		137 lbmass
18	*		MID PURLIN	HSS5X5X3/16		284 lbmass

**NOTE:
MATERIAL WILL VARY DEPENDING ON SHELTER SIZE ORDERED.

- CORNER COLUMN 8' UTB - (HSS8X8X1/4)
- SIDE COLUMN 8' UTB - (HSS10X8X5/16)
- CORNER COLUMN 10' UTB - (HSS8X8X1/4)
- SIDE COLUMN 10' UTB - (HSS10X8X5/16)
- CORNER COLUMN 12' UTB - (HSS10X8X5/16)
- SIDE COLUMN 12' UTB - (HSS12X8X5/16)

MODEL DESIGNATION

RH30X44	2 BAY
RH30X64	3 BAY
RH30X84	4 BAY
RH30X104	5 BAY

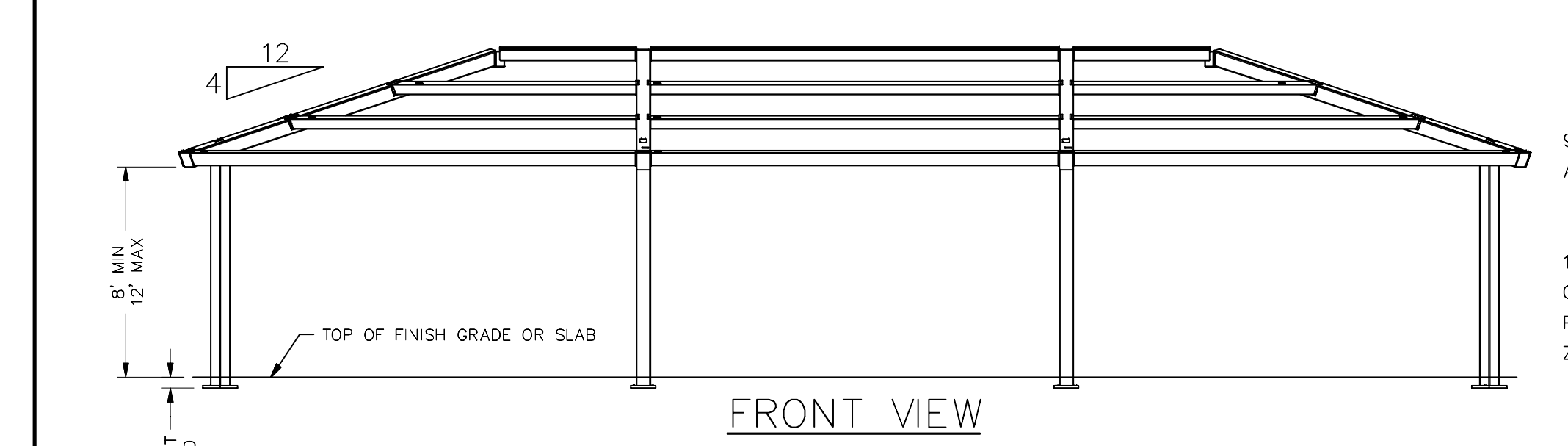

30' WIDE RECTANGULAR HIP

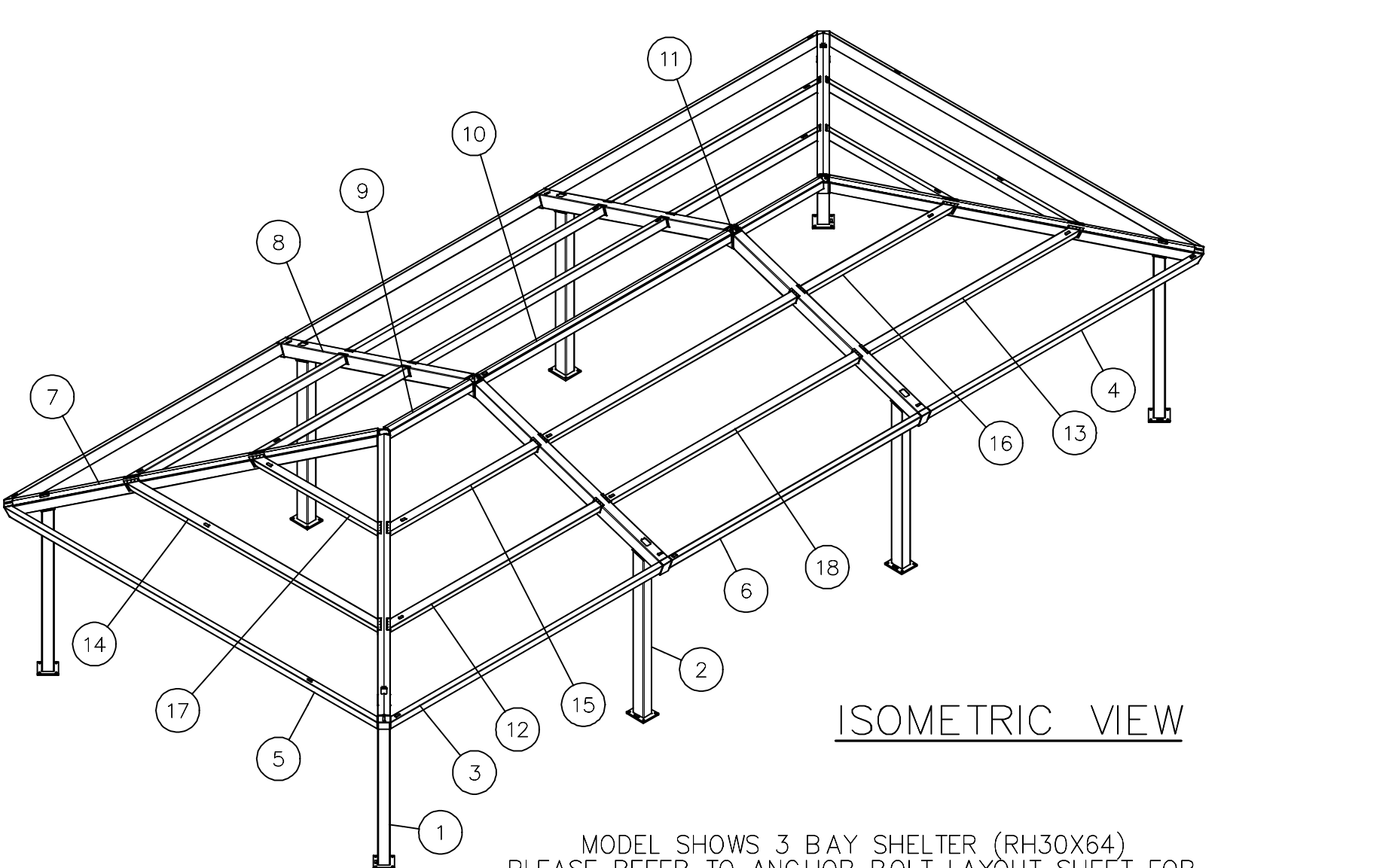
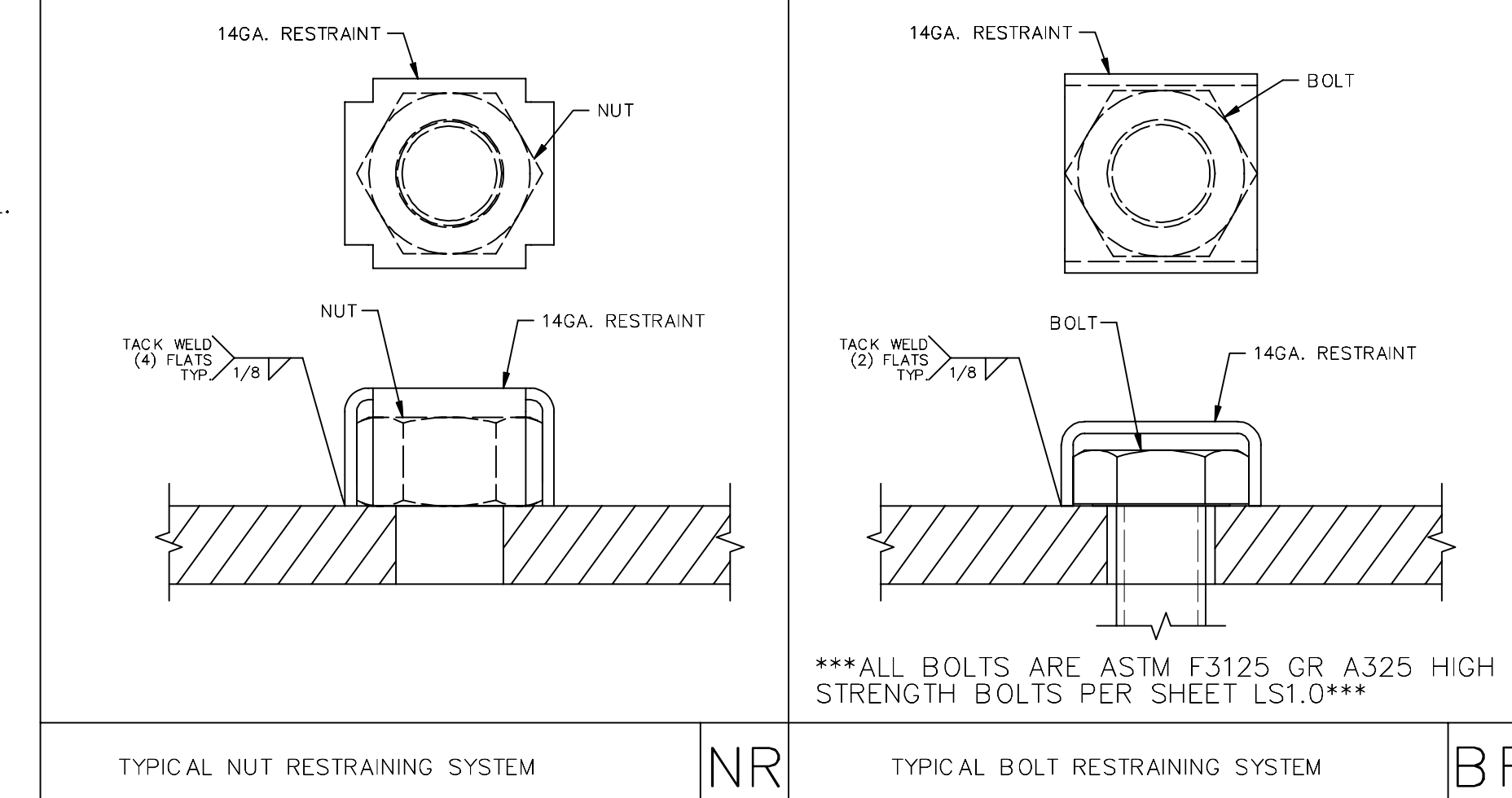

MODEL SHOWS 3 BAY SHELTER (RH30X64)
PLEASE REFER TO ANCHOR BOLT LAYOUT SHEET FOR
CORRECT COLUMN PLACEMENT BASED ON SIZE ORDERED

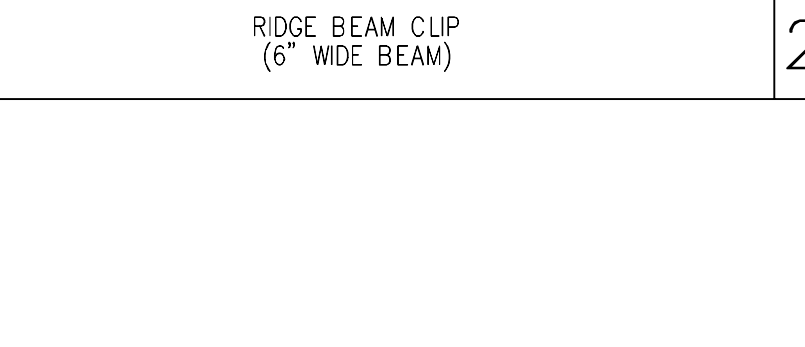
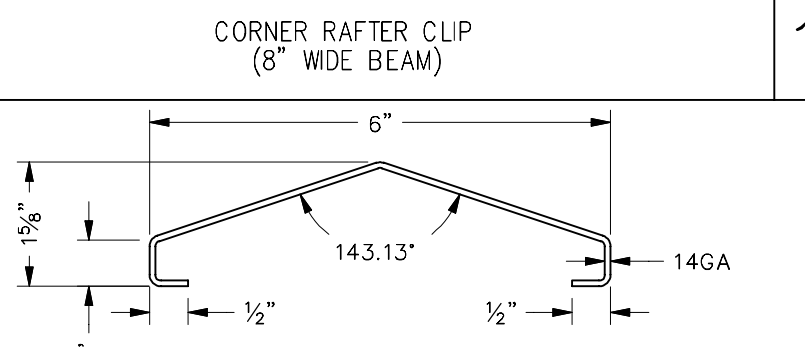
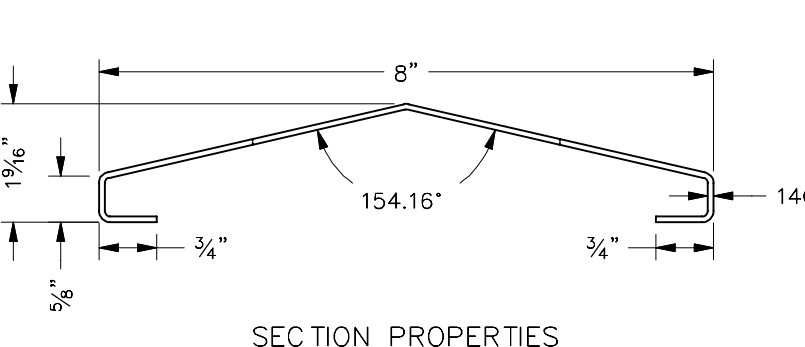

30' WIDE
RECTANGULAR HIP
FRAMING &
CONNECTION DETAILS

Shelter Systems Inc
DISTINCTIVE STEEL SHEDS™
WWW.ICONSHELTERS.COM
COPYRIGHT 2004, ICON SHELTER SYSTEMS, INC.
1455 LINCOLN AVE
HOLLAND MI, 49423
616.396.0919
800.748.0985
616.396.0944 FX

PRE-CHECK (PC) DOCUMENT
Code: 2019 CBC
A separate project application for construction is required.

LS3.1

SHADE STRUCTURE AT LEATAATA FLOYD
ELEMENTARY SCHOOL

SACRAMENTO CITY UNIFIED SCHOOL DISTRICT
SACRAMENTO, CA

Revision

PROJECT NO. 21-1504.03
DATE: 4/7/22
SHEET LS3.1
AD007

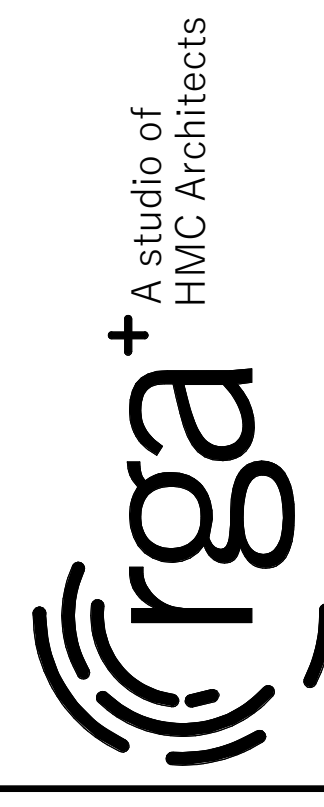

08/29/2021

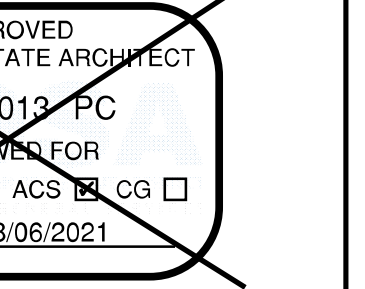

**SHADE STRUCTURE AT LEATAATA FLOYD
ELEMENTARY SCHOOL**
**SACRAMENTO CITY UNIFIED SCHOOL DISTRICT
SACRAMENTO, CA**

ROOF NOTES

ATTENTION INSTALLERS: METAL SHAVINGS LEFT ON ROOF WILL QUICKLY RUST AND STAIN THE ROOF FINISH!
DRILLING OR INSTALLING ROOF FASTENERS WILL CAUSE METAL SHAVINGS. THESE SHAVINGS MUST BE CAREFULLY REMOVED AT THE END OF EACH DAY BY EITHER SWEEPING OR BRUSHING THE INSTALLED ROOF.

INSTALLED CORRECTLY	INSTALLED TOO TIGHT	INSTALLED TOO LOOSE
THE SEALING MATERIAL SLIGHTLY VISIBLE AROUND THE EDGE OF THE METAL WASHER	THE SEALING MATERIAL IS DEFORMED BEYOND THE EDGE OF THE METAL WASHER	THE SEALING MATERIAL IS NOT VISIBLE AROUND THE EDGE OF THE METAL WASHER

THE DETAILS SHOWN ARE SUGGESTIONS OR GUIDELINES ON HOW TO ERECT THE METAL ROOFING SYSTEM. THE INFORMATION SHOWN IS ACCURATE, BUT IT IS NOT INTENDED TO COVER ALL INSTANCES. BUILDING REQUIREMENTS, DESIGNS OR CODES, CHANGES TO THE DETAILS MAY BE REQUIRED DUE TO FIELD CONDITIONS.
THE ERECTOR SHOULD THOROUGHLY FAMILIARIZE THEMSELVES WITH ALL INSTALLATION INSTRUCTION MATERIAL BEFORE STARTING WORK.
THE PANELS SHOULD BE INSTALLED PLUMB, STRAIGHT, AND ACCURATELY TO THE ADJACENT WORK.
ERECTORS SHALL BE RESPONSIBLE TO ENSURE THAT THE DETAILS MEET PARTICULAR BUILDING REQUIREMENTS AND TO ASSURE ADEQUATE WATER TIGHTNESS.
FOR THE BEST APPEARANCE ALL TRIM AND FLASHING SHALL BE INSTALLED TRUE, AND IN PROPER ALIGNMENT, WITH ALL EXPOSED FASTENERS EQUALLY SPACED.

SOME FIELD CUTTING AND/OR FITTING OF PANELS, TRIM AND FLASHING IS TO BE EXPECTED BY THE ERECTOR. MINOR FIELD CORRECTIONS ARE PART OF NORMAL ERECTION WORK.
THE INSTALLATION SHALL BE PERFORMED BY EXPERIENCED METAL CRAFTSMEN AND WORKMANSHIP SHALL MEET THE BEST INDUSTRY STANDARDS.

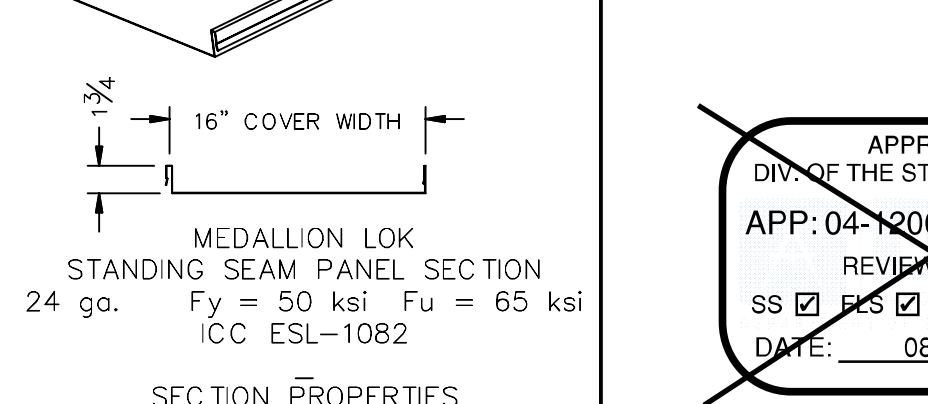
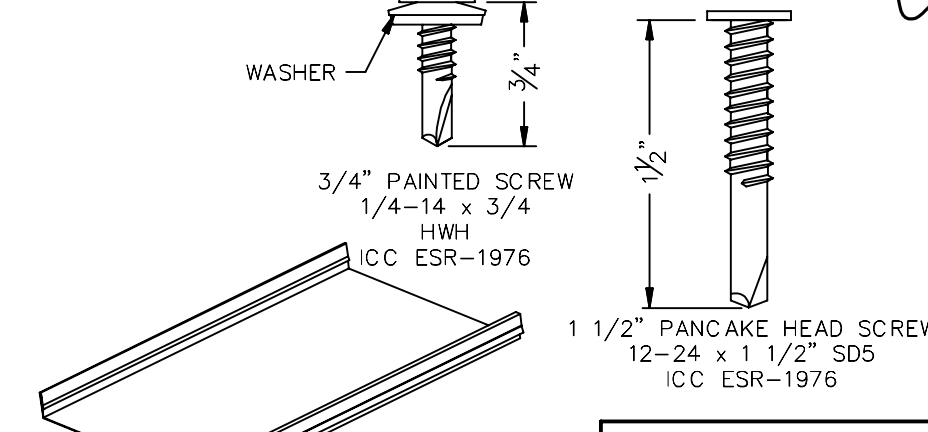

SECTION PROPERTIES (PER FT. OF WIDTH)
TOP IN COMPRESSION
 $I_x = 0.086 \text{ in}^4$
 $S_x = 0.0561 \text{ in}^3$
 $M_x = 1.58 \text{ in-kips}$
BOTTOM IN COMPRESSION
 $I_x = 0.040 \text{ in}^4$
 $S_x = 0.0479 \text{ in}^3$
 $M_x = 1.248 \text{ in-kips}$

TRIM REFERENCE

ORDER OF INSTALLATION

FIELD CUTTING ROOF PANELS S-CP1

INSTALLATION OF FIRST ROOF PANEL S-P11

INSTALLATION OF SECOND ROOF PANEL S-P12

INSTALLATION OF HIP C-CLOSURE S-HC1

INSTALLATION OF C-CLOSURE @ RIDGE S-RC1

INSTALLATION OF CORNER TRIM S-C11

INSTALLATION OF HIP CAP S-HT1

INSTALLATION OF RIDGE CAP S-RT1

OPTIONAL GUTTER INSTALLATION STANDING SEAM ROOF GU1

OPTIONAL GUTTER SECTION STANDING SEAM ROOF GU2

30' WIDE RECTANGULAR HIP STANDING SEAM ROOFING

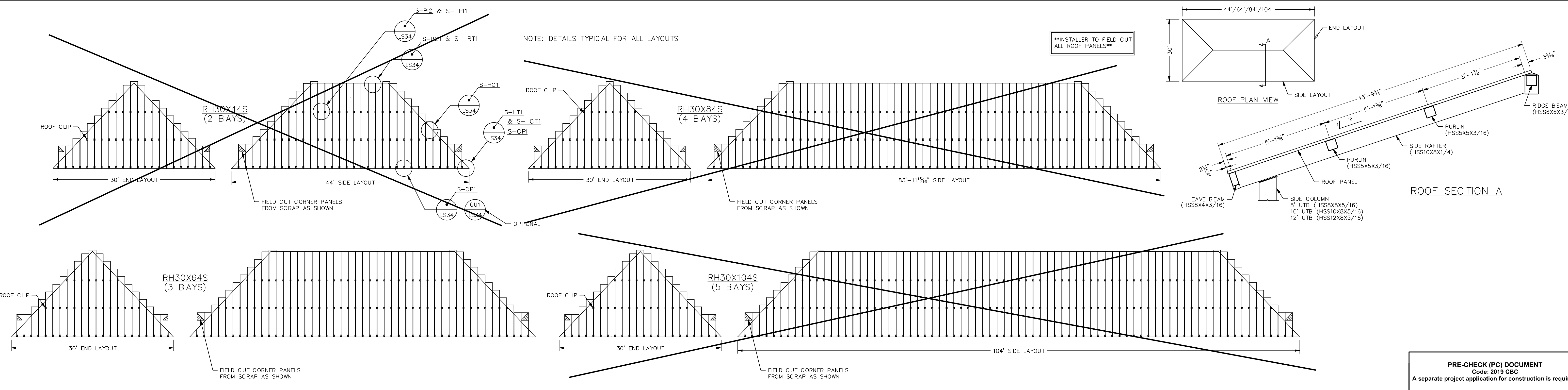

30' WIDE RECTANGULAR HIP STANDING SEAM ROOFING PLAN

CON Shelter Systems Inc.
DISTRICTOR STEEL SHELTERS
WWW.CONSHELTER.COM
COPYRIGHT 2004, CON SHELTER SYSTEMS, INC.
1455 LINCOLN AVE
HOLLAND MI, 49423
616.396.0919
800.748.0985
616.396.0944 FX

PRE-CHECK (PC) DOCUMENT
Code: 2019 CBC
A separate project application for construction is required.

LS3.4

Revision	
Copyright © 2021 Rainform Grau Architects. All rights reserved. Reproduction of these plans, either in whole or in part, including any form of copying and/or preparation of derivative works thereof, for any reason without prior written permission, is strictly prohibited.	
30' WIDE RECTANGULAR HIP STANDING SEAM ROOFING PLAN	
PROJECT NO. 21-1504.03	
DATE: 4/7/22	
SHEET	LS3.4

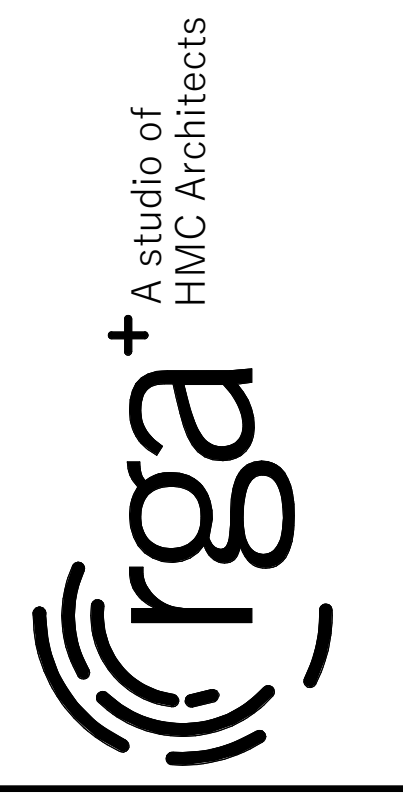

ELECTRICAL INFORMATION - RECTANGULAR HIP

ICON'S STANDARD ELECTRICAL IS DESIGNED TO ACCOMMODATE Ø1/2" CONDUIT WITH A Ø3" INLET HOLE ON THE BOTTOM OF EACH COLUMN. THE CONDUIT PATHWAY RUNS THROUGH THE COLUMN, RAFTER, AND RIDGE BEAM THROUGH ALL BOLTED CONNECTIONS AS SHOWN. IF YOU HAVE SPECIAL ELECTRICAL REQUIREMENTS, PLEASE OUTLINE ANY CHANGES BELOW AS DESCRIBED.

PLEASE NOTE: DESIGN LIMITATIONS ON HOLE/CUTOUT SIZES MAY APPLY. ICON WILL REACH OUT TO DISCUSS ANY SUCH LIMITATIONS AS NEEDED.

NOTE: ICON SHELTER FRAME IS NOT UL LISTED TO ACT AS A CONDUIT FOR ELECTRICAL WIRING. CONSULT LOCAL BUILDING CODES WHEN PLANNING YOUR ELECTRICAL SYSTEM.

PRELIMINARY: NOT FOR CONSTRUCTION

- STEPS:**
1. CONDUIT HOLE SIZE (DETAIL A)
 2. ELECTRICAL EXIT HOLES (DETAIL B)
 3. ELECTRICAL ACCESS & COVER PLATES (DETAIL C)
 4. ELECTRICAL CONDUIT PATHWAY (DETAIL D)

IF REQUIRED, PLEASE DRAW THE NECESSARY ELECTRICAL CONDUIT PATHWAY ON THE FRAME SHEET OF THIS PRELIMINARY.

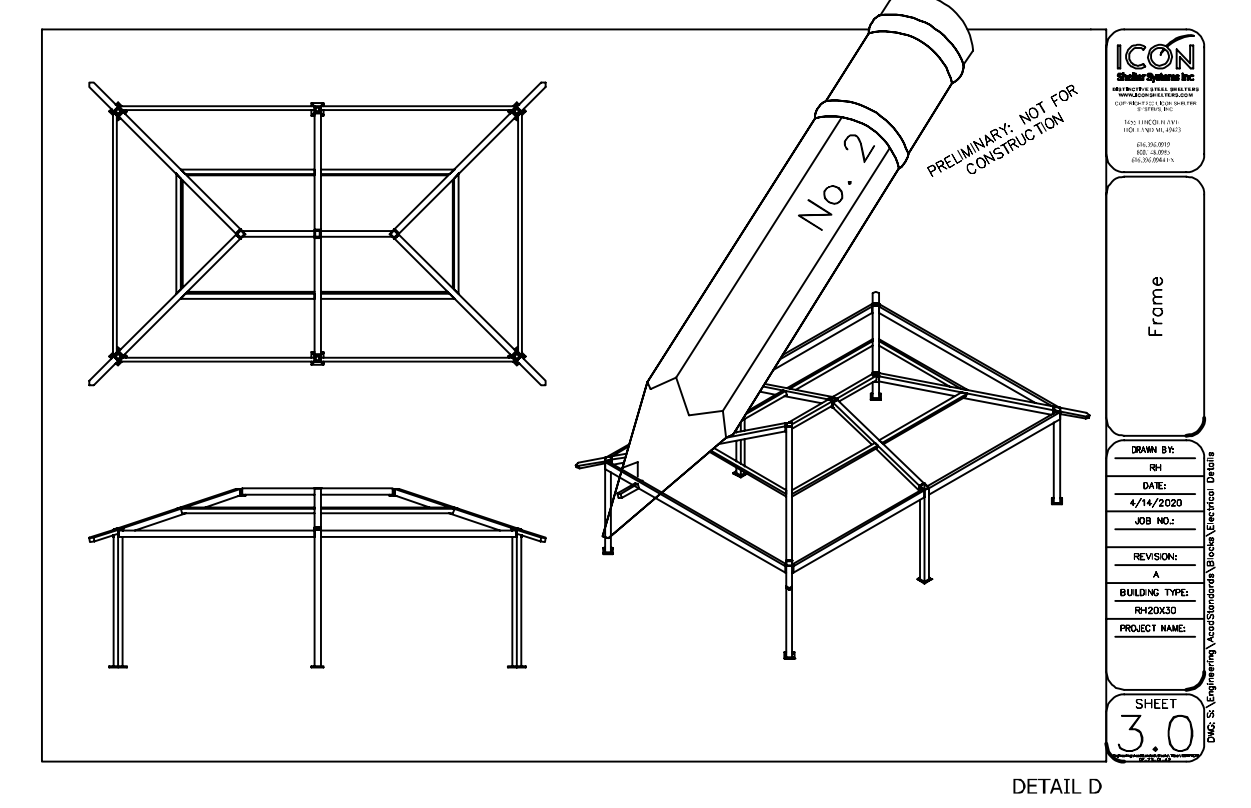

OPTIONAL EXIT HOLES
 IF REQUIRED, EXIT HOLES FOR LIGHTING, ETC. CAN BE PLACED IN THE RIDGE BEAM AND/OR CONNECTOR TUBE WITH 14ga COVER PLATE AS SHOWN (CHARGES APPLY). USE FRAME SHEET OF THIS PRELIMINARY TO SPECIFY REQUIRED EXIT HOLE LOCATIONS AND SIZE.

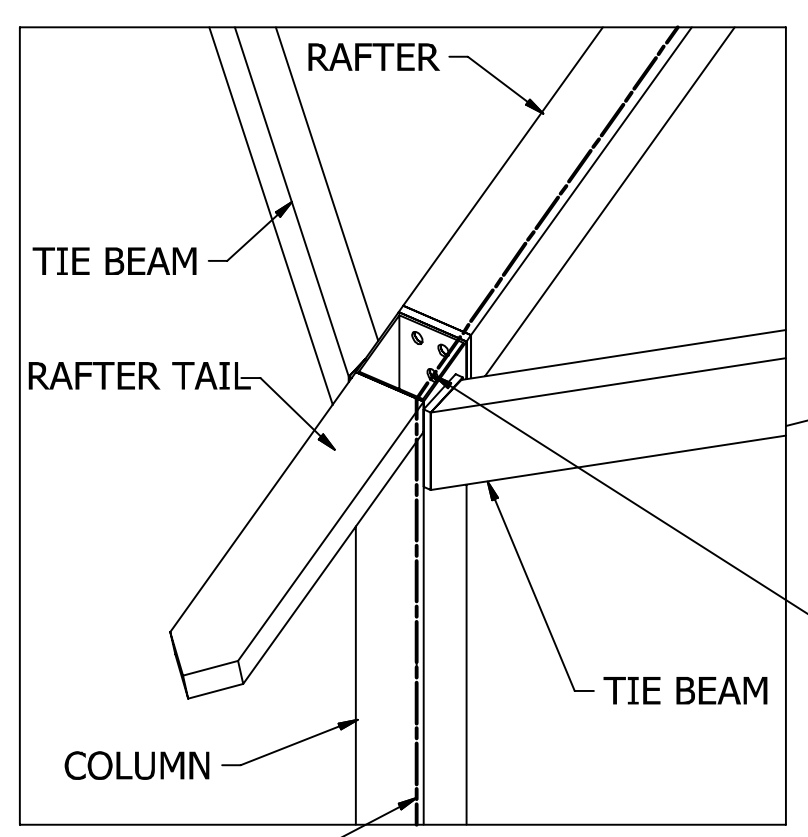
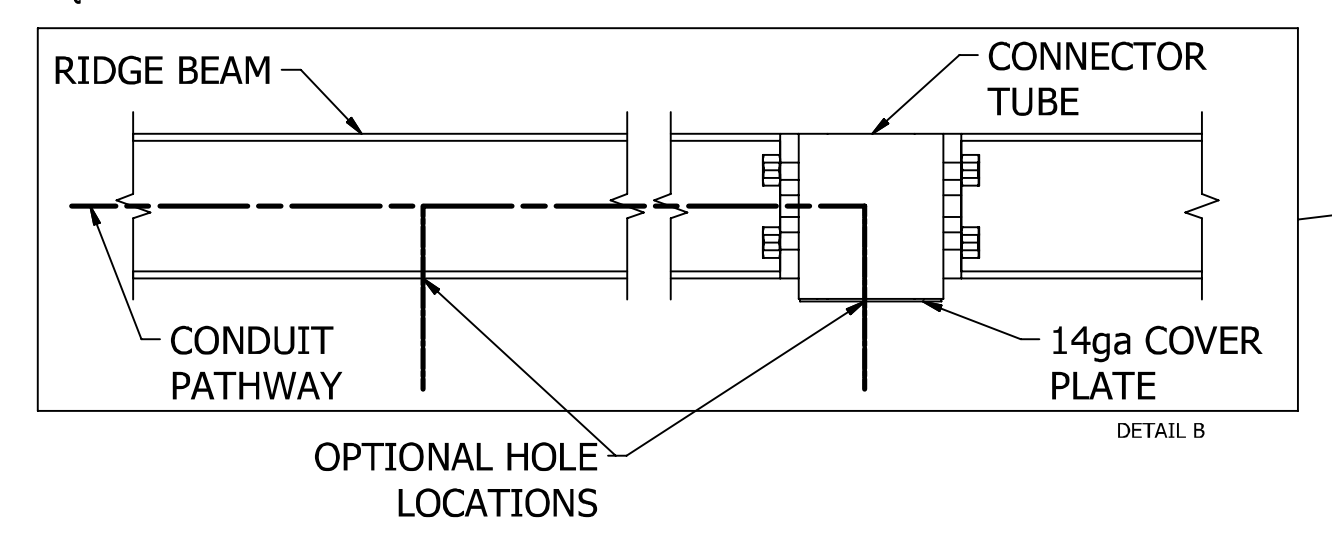

ICON PROVIDES A MINIMUM OF (1) 3/4" HOLE AT EACH CONNECTION FOR 1/2" CONDUIT. IF APPLICABLE, PLEASE SPECIFY REQUIRED CONDUIT SIZE: (CHARGES APPLY)

- 3/4" CONDUIT (1" HOLES)
- 1" CONDUIT (1 1/4" HOLES)
- OTHER (PLEASE SPECIFY)

CONDUIT PATHWAY PROVIDED FOR EACH COLUMN.

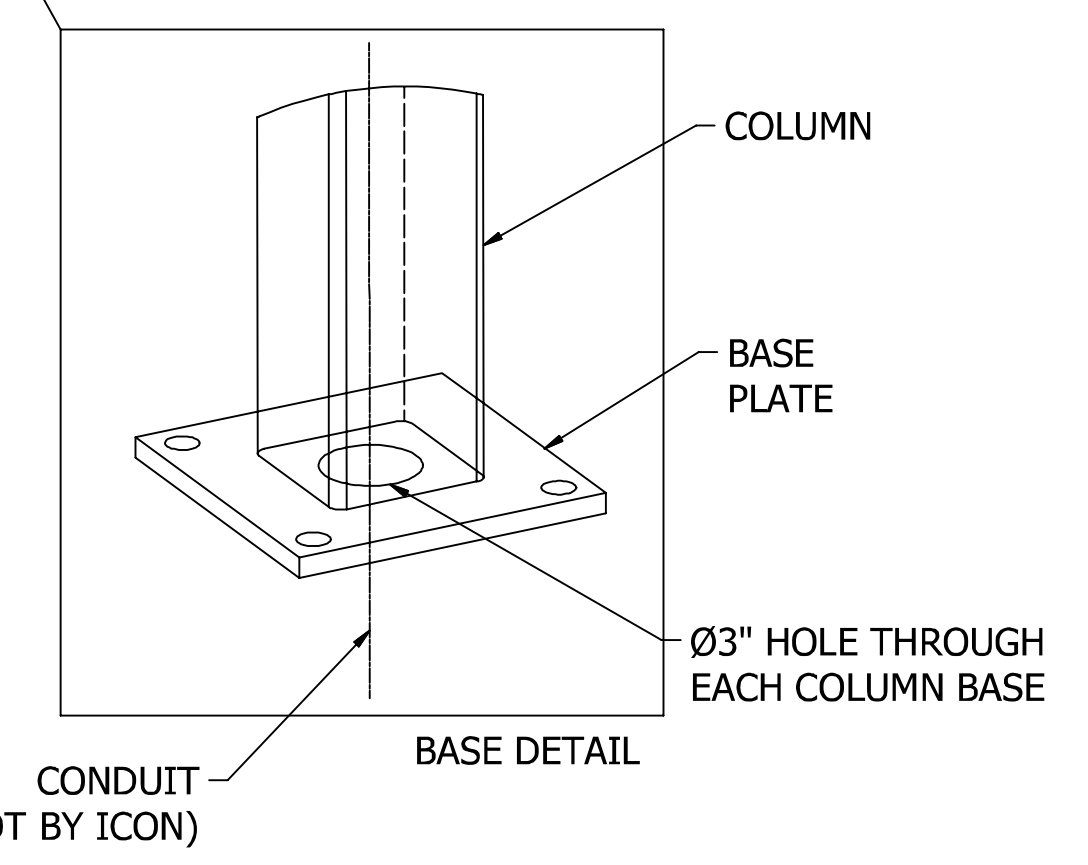

OPTIONAL CUTOUTS
 USE FRAME SHEET OF THIS PRELIMINARY TO SPECIFY REQUIRED CUTOUT LOCATIONS (CHARGES APPLY). SEE REQUIRED INFO BELOW

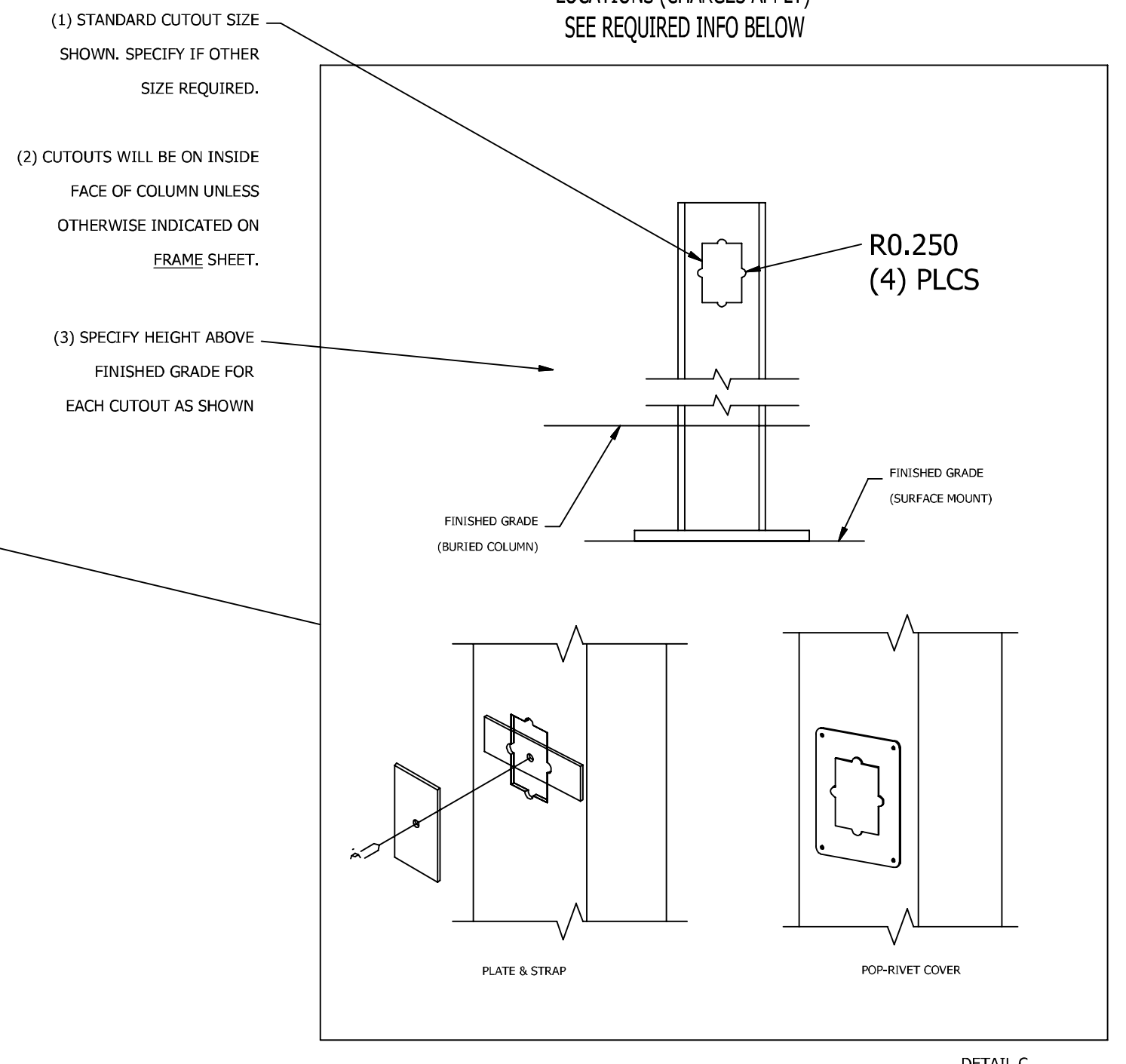

- (1) STANDARD CUTOUT SIZE SHOWN. SPECIFY IF OTHER SIZE REQUIRED.
- (2) CUTOUTS WILL BE ON INSIDE FACE OF COLUMN UNLESS OTHERWISE INDICATED ON FRAME SHEET.
- (3) SPECIFY HEIGHT ABOVE FINISHED GRADE FOR EACH CUTOUT AS SHOWN

(4) COVER PLATES PROVIDED UPON REQUEST (CHARGES APPLY). PLEASE SPECIFY TYPE AND QUANTITY REQUIRED:
 PLATE & STRAP
 POP-RIVET COVER
 HOW MANY REQUIRED? _____

NOTE: BUILDING DEPICTED ON THIS SHEET FOR ILLUSTRATION PURPOSES ONLY. ACTUAL LAYOUT AND FRAME MEMBER QUANTITIES VARY BY DESIGN. PLEASE REFER TO ELEVATION AND FRAME SHEETS IN THIS PRELIMINARY FOR ORDER-SPECIFIC CONFIGURATION.

ICON STD	R4/OSA-PC
DRAWN BY	ANGEL
DATE	4/2/2021
REV	
REV DATE	

JRMA
 ARCHITECTS ENGINEERS
 2200 SATORI ST BRSA, CA 95821
 1714224-8039 / 916-424-9173
 WWW.JRMA.COM

PROFESSIONAL SEAL
 MICHAEL D. JOHNSON
 REGISTERED PROFESSIONAL ARCHITECT
 STATE OF CALIFORNIA
 07/29/2021

APPROVED
 DIV. OF THE STATE ARCHITECT
 APP: 04-20013-PC
 REVIEWED FOR
 SS PLS ACS CG
 DATE: 08/08/2021

ELECTRICAL ACCESS

ICON Shelter Systems Inc
 DISTINCTIVE STEEL SHELTERS
 WWW.ICONSHELTERS.COM
 COPYRIGHT 2004, ICON SHELTER SYSTEMS, INC.
 1455 LINCOLN AVE
 HOLLAND MI, 49423
 616.396.0919
 800.748.0985
 616.396.0944 FX

LS5.0

PRE-CHECK (PC) DOCUMENT
 Code: 2019 CBC
 A separate project application for construction is required.

PRINTED ON :

SHADE STRUCTURE AT LEATAATA FLOYD ELEMENTARY SCHOOL
 SACRAMENTO CITY UNIFIED SCHOOL DISTRICT
 SACRAMENTO, CA

Revision	
----------	--

Copyright © 2021 Rainforth Grau Architects. All rights reserved. Reproduction of these plans, either in whole or in part, including any form of copying and/or preparation of derivative works thereof, for any reason without prior written permission, is strictly prohibited.

ELECTRICAL ACCESS

PROJECT NO.	21-1504.03
DATE:	4/7/22
SHEET	LS5.0

EXISTING TOPOGRAPHY

- = PROPERTY LINE
- - - = CENTERLINE
- - - = EASEMENT
- ⊕ = PROPERTY CORNER FOUND AS NOTED
- = PROPERTY CORNER NOTHING FOUND OR SET
- △123 = TEMPORARY BENCHMARK (SEE TBM LIST FOR INFO)
- = SWALE OR DRAINAGE FLOW
- = DRAINAGE FLOW
- = FENCE (TYPE NOTED)
- = TREE (SIZE/TYPE INDICATED)
- = SLOPE
- 100 = CONTOUR
- CONCRETE = CONCRETE SURFACE
- ASPHALT = EDGE OF ASPHALT
- EDGE OF BUILDING = EDGE OF BUILDING
- = SIGN
- = POST OR BOLLARD
- 99.9 = GROUND ELEVATION
- 99.99 = HARD SURFACE ELEVATION

EXISTING UTILITIES

- 12" SD → = STORM DRAIN LINE (SIZE & DIRECTION OF FLOW)
- 12" SD - - - = STORM DRAIN LINE (RECORD INFORMATION)
- 12" SD - - - = STORM DRAIN LINE (UNDERGROUND LOCATING)
- ⊙ = STORM DRAIN MANHOLE
- = STORM DRAIN CLEANOUT
- = DROP INLET
- = AREA DRAIN
- = RAIN WATER LEADER
- DS = DOWNSPOUT
- 12" SS → = SANITARY SEWER LINE (SIZE & DIRECTION OF FLOW)
- 12" SS - - - = SANITARY SEWER LINE (RECORD INFORMATION)
- 12" SS - - - = SANITARY SEWER LINE (UNDERGROUND LOCATING)
- ⊙ = SANITARY SEWER MANHOLE
- = SANITARY SEWER CLEANOUT
- W = WATER LINE (SIZE INDICATED)
- W - - - = WATER LINE (RECORD INFORMATION)
- W - - - = WATER LINE (UNDERGROUND LOCATING)
- ⊙ = WATER MANHOLE
- ⊙ = WATER VALVE
- ⊙ = WATER METER
- ⊙ = WATER BOX
- ⊙ = IRRIGATION CONTROL VALVE
- ⊙ = FIRE HYDRANT
- ⊙ = BACKFLOW PREVENTER
- ⊙ = SPRINKLER
- ⊙ = HOSE BIBB
- OH-E = OVERHEAD ELECTRIC LINE
- E - - - = UNDERGROUND ELECTRIC LINE
- E - - - = UNDERGROUND ELECTRIC LINE (RECORD INFORMATION)
- E - - - = UNDERGROUND ELECTRIC LINE (UNDERGROUND LOCATING)
- ⊙ = ELECTRIC MANHOLE
- ⊙ = UTILITY POLE (WITH GUY WIRE)
- ⊙ = ELECTRIC METER
- ⊙ = ELECTRIC BOX
- ⊙ = STREET LIGHTING BOX
- ⊙ OR ⊙ = LIGHT STANDARD
- ⊙ = SIGNAL LIGHT
- ⊙ = FLOOD LIGHT
- ⊙ = ELECTRICAL OUTLET
- G = GAS LINE (SIZE INDICATED)
- G - - - = GAS LINE (RECORD INFORMATION)
- G - - - = GAS LINE (UNDERGROUND LOCATING)
- ⊙ = GAS MANHOLE
- ⊙ = GAS VALVE
- ⊙ = GAS METER
- T = TELEPHONE LINE
- T - - - = TELEPHONE LINE (RECORD INFORMATION)
- T - - - = TELEPHONE LINE (UNDERGROUND LOCATING)
- ⊙ = STORM DRAIN BOX
- ⊙ = TRAFFIC SIGNAL BOX

CIVIL ABBREVIATIONS AND LEGEND

ABBREVIATIONS

- NOTE: NOT ALL ABBREVIATIONS MAY BE USED ON THESE PLANS.
- AB AGGREGATE BASE
 - AC ASPHALT TO CONCRETE
 - AD AREA DRAIN
 - APN ASSESSOR'S PARCEL NUMBER
 - ARV AIR RELEASE VALVE
 - ASB AGGREGATE SUB-BASE
 - BO BLOW-OFF VALVE
 - BV BUTTERFLY VALVE
 - BW BACK OF WALK
 - CB CENTERLINE
 - CB CATCH BASIN
 - CL CLASS
 - CMP CORRUGATED METAL PIPE
 - CATV CABLE TELEVISION
 - CO CLEANOUT
 - COMM COMMUNICATION
 - CONC CONCRETE
 - CONST. CONSTRUCT
 - CR CURB RETURN
 - CS CONCRETE SURFACE
 - DC DOUBLE CHECK VALVE
 - DDC DOUBLE DETECTOR CHECK VALVE
 - DG DECOMPOSED GRANITE
 - DI DROP INLET
 - DIA DIAMETER
 - DIP DUCTILE IRON PIPE
 - DWG DRAWING
 - DS DOWNSPOUT
 - E ELECTRIC
 - EP EDGE OF PAVEMENT
 - ESMT EASEMENT
 - EX EXISTING
 - FS FIRE SERVICE LINE
 - FDC FIRE DEPARTMENT CONNECTION
 - FL FLOWLINE
 - FM SANITARY SEWER FORCE MAIN
 - FF FINISHED FLOOR ELEVATION
 - FH FIRE HYDRANT
 - G GAS
 - GRD GRATE ELEVATION
 - GV GATE VALVE
 - HB HOSE BIBB
 - HBD HEADER BOARD
 - HDPE HIGH DENSITY POLYETHYLENE PIPE
 - HP HIGH POINT
 - INV PIPE INVERT ELEVATION
 - JP JOINT UTILITY POLE
 - LF LINEAL FEET
 - LIP LIP OF GUTTER
 - LT LEFT
 - MS MOWSTRIP
 - NOT TO SCALE
 - OH OVERHEAD
 - PC PORTLAND CEMENT CONCRETE
 - PCC PLANTER DRAIN
 - PIV POST INDICATOR VALVE
 - P/L PROPERTY LINE
 - PP POWER POLE
 - PUE PUBLIC UTILITY EASEMENT
 - PVC POLYVINYL CHLORIDE
 - RCP REINFORCED CONCRETE PIPE
 - R RADIUS
 - RIM MANHOLE RIM ELEVATION (SOLID COVER)
 - RP REDUCED PRESSURE BACKFLOW PREVENTER
 - RIGHT OF WAY
 - SCH SCHEDULE
 - SD STORM DRAIN
 - SDMH STORM DRAIN MANHOLE
 - SG SUBGRADE ELEVATION
 - SS SANITARY SEWER
 - SSMH SANITARY SEWER MANHOLE
 - STD STANDARD
 - S/W SIDEWALK
 - T TELEPHONE
 - TC TOP OF CURB
 - TD TRENCH DRAIN
 - TD CB TRENCH DRAIN CATCH BASIN
 - TP TELEPHONE POLE
 - TR TOP OF RAMP ELEVATION
 - TRW TOP OF RETAINING WALL
 - TSW TOP OF SEAT WALL
 - TW TOP OF WALK ELEVATION
 - UTILITY
 - UG UNDERGROUND
 - UNLESS OTHERWISE NOTED
 - VCP VITRIFIED CLAY PIPE
 - W WATER
 - WITH
 - W/O WITHOUT
 - WW WATER VALVE

LEGEND

NOTE: NOT ALL SYMBOLS MAY BE USED ON THESE PLANS.

PROPOSED GRADING & DRAINAGE SYMBOLS:

- 8" SD → = STORM DRAIN LINE (SIZE AND FLOW SHOWN)
- = STORM DRAIN MANHOLE (SDMH)
- = CATCH BASIN (CB)
- = DROP INLET (DI)
- = AREA DRAIN (AD)
- = PLANTER DRAIN (PD) OR FLOOR DRAIN (FD)
- CO → = STORM DRAIN CLEANOUT
- 99.99 → = ELEVATION
- FF=100.00 → = FINISHED FLOOR ELEVATION
- PAD=99.33 → = BUILDING PAD ELEVATION
- CONCRETE SIDEWALK
- = GRADED DIRECTION FOR DRAINAGE FLOW
- = SWALE
- = SLOPE
- ⊗ = TREE TO BE REMOVED
- = RETAINING WALL

PROPOSED SANITARY SEWER SYMBOLS:

- 6" SS → = SANITARY SEWER LINE (SIZE AND FLOW SHOWN)
- ⊙ = SANITARY SEWER MANHOLE (SSMH)
- CO → = SEWER CLEANOUT FLUSHER BRANCH

PROPOSED WATER SYMBOLS:

- 8" W → = WATER LINE & SIZE
- 8" FS → = FIRE LINE & SIZE
- 8" DW → = DOMESTIC WATER LINE & SIZE
- 8" RW → = RECLAIMED WATER LINE & SIZE
- 8" IRR → = IRRIGATION SERVICE LINE & SIZE
- 8" NP → = NON POTABLE WATER LINE & SIZE
- 8" SP → = FIRE SPRINKLER SERVICE LINE & SIZE
- = GATE VALVE
- M → = WATER METER
- FH = FIRE HYDRANT ASSEMBLY
- Y FDC = FIRE DEPARTMENT CONNECTION
- ⊙ = DETECTOR CHECK VALVE
- ⊙ = DOUBLE DETECTOR CHECK VALVE
- ⊙ = REDUCED PRESSURE BACKFLOW PREVENTER
- N → = BUTTERFLY VALVE
- 1" → = AIR RELEASE VALVE + SIZE
- 1" → = BLOW-OFF VALVE + SIZE
- PIV → = POST INDICATOR VALVE

DEMOLITION GENERAL NOTES

- IN THE EVENT THAT ANY UNUSUAL CONDITIONS NOT COVERED BY THE GEOTECHNICAL INVESTIGATION REPORT OR ARE ENCOUNTERED DURING GRADING OPERATIONS THE GEOTECHNICAL ENGINEER AND THE ARCHITECT SHALL BE IMMEDIATELY NOTIFIED FOR DIRECTIONS.
- NO BURNING OR BLASTING SHALL BE PERMITTED.
- ADDITIONAL DEMOLITION INFORMATION MAY BE SHOWN ON THE GRADING, DRAINAGE, AND UTILITY PLANS, AND THOSE PLANS PREPARED BY OTHER DISCIPLINES FOR THIS PROJECT.
- ALL DEMOLISHED ITEMS SHALL BE DISPOSED OF OFFSITE AT A SUITABLE, LEGAL, DUMP SITE OR OTHER FACILITY.
- ALL DISPOSED OF MATERIALS SHALL BE RECYCLED IF POSSIBLE.
- THE TYPES, LOCATIONS, SIZES AND/OR DEPTHS OF EXISTING UNDERGROUND UTILITIES AS SHOWN IN THESE PLANS WERE OBTAINED FROM SOURCES OF VARYING RELIABILITY. THE CONTRACTOR IS CAUTIONED THAT ONLY ACTUAL EXCAVATION WILL REVEAL THE TYPES, EXTENT, SIZES, LOCATIONS, AND DEPTHS OF SUCH UNDERGROUND UTILITIES. A REASONABLE EFFORT HAS BEEN MADE TO LOCATE AND DELINEATE ALL KNOWN UNDERGROUND UTILITIES. HOWEVER, WARREN CONSULTING ENGINEERS CAN ASSUME NO RESPONSIBILITY FOR THE COMPLETENESS OR ACCURACY OF ITS DELINEATION OF SUCH UNDERGROUND UTILITIES, NOR FOR THE EXISTENCE OF OTHER BURIED OBJECTS OR UTILITIES WHICH MAY BE ENCOUNTERED BUT WHICH ARE NOT SHOWN ON THESE DRAWINGS. THE CONTRACTOR OR ANY SUBCONTRACTOR FOR THIS CONTRACT SHALL NOTIFY MEMBERS OF UNDERGROUND SERVICE ALERT (USA) TWO (2) WORKING DAYS IN ADVANCE OF PERFORMING ANY EXCAVATION WORK BY CALLING TOLL FREE 1-800-227-2600, OR 811.
- THE SCHOOL DISTRICT SHALL HAVE SALVAGE RIGHTS TO ANY DEMOLISHED ITEMS SHOWN HEREON. THE CONTRACTOR SHALL GIVE THE DISTRICT NOTICE 7 DAYS PRIOR TO THE START OF DEMOLITION. THE DISTRICT SHALL MOVE ANY RETAINED ITEMS OUT OF THE CONTRACTORS WORK AREA, UNLESS ANOTHER ARRANGEMENT IS MADE WITH THE CONTRACTOR. ANY REMAINING ITEMS BECOME THE PROPERTY OF THE CONTRACTOR AND SHALL BE REMOVED FROM THE SITE. ANY ITEMS NOT SHOWN FOR REMOVAL SHALL REMAIN AND SHALL BE PROTECTED FROM DAMAGE DURING CONSTRUCTION TO A REASONABLE EXTENT.
- EXISTING UTILITY STRUCTURES IN AREAS OF NEW PAVING SHALL BE REMOVED AND REPLACED WITH NEW BOX/COVER AT NEW GRADE UNLESS SPECIFICALLY NOTED OTHERWISE.
- ITEMS OUTSIDE THE LIMITS OF DEMOLITION SHALL REMAIN AND BE PROTECTED FROM DAMAGE DURING CONSTRUCTION.
- EXISTING UTILITY STRUCTURES AND PIPING NOT SHOWN ON DEMOLITION PLAN TO BE REMOVED SHALL REMAIN AND BE PROTECTED.

UTILITY VERIFICATION NOTE

PRIOR TO THE START OF CONSTRUCTION, VERIFY AND POTHOLE ALL UTILITY POINTS OF CONNECTION FOR LOCATION, DEPTH, AND SIZE. IF CONFLICT IS FOUND, CONTACT THE ENGINEER IMMEDIATELY FOR DIRECTION.

IRRIGATION DEMOLITION NOTE

WITHIN LANDSCAPE AREAS TO BE DEMOLISHED THERE MAY BE EXISTING IRRIGATION LINES NOT SHOWN ON THIS PLAN. CONTRACTOR SHALL REMOVE LATERAL LINES AND HEADS ENCOUNTERED. MAIN LINES AND CONTROL WIRES MAY ONLY BE REMOVED PROVIDED THAT ROUTING IS KNOWN AND REMOVAL WILL NOT DEACTIVATE AN IRRIGATION SYSTEMS INTENDED TO REMAIN. IF CONFLICT IS FOUND, CONTACT THE ENGINEER FOR DIRECTION.

GENERAL NOTES

- THE TYPES, LOCATIONS, SIZES, AND/OR DEPTHS OF EXISTING UNDERGROUND UTILITIES AS SHOWN ON THESE PLANS WERE OBTAINED FROM SOURCES OF VARYING RELIABILITY. THE CONTRACTOR IS CAUTIONED THAT ONLY ACTUAL EXCAVATION WILL REVEAL THE TYPES, EXTENT, SIZES, LOCATIONS AND DEPTHS OF SUCH UNDERGROUND UTILITIES. A REASONABLE EFFORT HAS BEEN MADE TO LOCATE AND DELINEATE ALL KNOWN UNDERGROUND UTILITIES. HOWEVER, WARREN CONSULTING ENGINEERS CAN ASSUME NO RESPONSIBILITY FOR THE COMPLETENESS OR ACCURACY OF ITS DELINEATION OF SUCH UNDERGROUND UTILITIES, NOR FOR THE EXISTENCE OF OTHER BURIED OBJECTS OR UTILITIES WHICH MAY BE ENCOUNTERED BUT WHICH ARE NOT SHOWN ON THESE PLANS. THE CONTRACTOR OR ANY SUBCONTRACTOR FOR THIS CONTRACT SHALL NOTIFY MEMBERS OF UNDERGROUND SERVICE ALERT (USA) TWO (2) WORKING DAYS IN ADVANCE OF PERFORMING ANY EXCAVATION WORK BY CALLING TOLL FREE 1-800-227-2600, OR 811.
- WARREN CONSULTING ENGINEERS, INC. (WCE) ASSUMES NO RESPONSIBILITY FOR ERRORS IN PHYSICAL LOCATION OF IMPROVEMENTS, HORNS, OR VERTICALS TAKEN BY OTHERS. IN ADDITION, ANY SUCH ERRORS IN PHYSICAL LOCATION MAY AFFECT THE INTENDED DESIGN OF SUCH IMPROVEMENTS AND WCE CANNOT BE HELD RESPONSIBLE FOR SUCH CONDITIONS WHICH ARE A RESULT OF ERRORS IN SURVEYING, OR IMPROPER CONSTRUCTION.
- IF SUBSURFACE CULTURAL RESOURCES, REMAINS, AND/OR ARTIFACTS ARE UNCOVERED DURING PROJECT CONSTRUCTION, ALL WORK IN THE VICINITY SHALL BE STOPPED UNTIL SUCH ITEMS CAN BE ASSESSED BY AN APPROPRIATE MEMBER OF THE COUNTY ENVIRONMENTAL IMPACT SECTION STAFF.
- CONTRACTOR AGREES THAT HE/SHE SHALL ASSUME SOLE AND COMPLETE RESPONSIBILITY FOR JOB SITE CONDITIONS DURING THE COURSE OF CONSTRUCTION INCLUDING SAFETY OF ALL PERSONS AND PROPERTY. THAT THIS REQUIREMENT SHALL APPLY CONTINUOUSLY AND SHALL NOT BE LIMITED TO NORMAL WORKING HOURS; AND THAT THE CONTRACTOR SHALL DEFEND, INDEMNIFY AND HOLD THE OWNER AND ENGINEER HARMLESS FROM ANY AND ALL LIABILITY, REAL OR ALLEGED, IN CONNECTION WITH THE PERFORMANCE OF WORK ON THIS PROJECT, EXCEPTING FOR LIABILITY ARISING FROM THE SOLE NEGLIGENCE OF THE OWNER OR ENGINEER.
- THE CONTRACTOR SHALL OBTAIN AN EXCAVATION PERMIT FROM THE STATE OF CALIFORNIA DEPARTMENT OF INDUSTRIAL SAFETY FOR ALL EXCAVATIONS OF 5 FEET OR MORE IN DEPTH.
- IT SHALL BE THE CONTRACTOR'S RESPONSIBILITY TO MAKE ALL NECESSARY PRE-BID AND PRE-CONSTRUCTION SITE INSPECTION, AND/OR OBSERVATIONS ON THE SITE TO PRE-DETERMINE ALL HIS/HER MEANS AND METHODS NECESSARY TO COMPLETE THE IMPROVEMENTS SHOWN ON THESE PLANS AND PER THE PROJECT SPECIFICATIONS. IT IS THE CONTRACTOR'S RESPONSIBILITY TO DETERMINE, AND INCLUDE IN HIS/HER CONTRACT, ALL MEANS AND METHODS NECESSARY TO PERFORM A COMPLETE AND ACCEPTABLE JOB.
- WHERE IMPROVEMENTS LIE WITHIN AN EXISTING DEVELOPED AREA, CONTRACTOR SHALL USE CAUTION WHEN ACCESSING THE SITE THROUGH THESE EXISTING IMPROVEMENTS. IT IS THE CONTRACTOR'S RESPONSIBILITY TO PROTECT ANY SUCH EXISTING IMPROVEMENTS OUTSIDE THE PROJECT BOUNDARY, OR EXISTING IMPROVEMENTS WITHIN THE BOUNDARY WHICH ARE REMAINS FOR PATCH BACK IF EDGE IS DAMAGED. A NEW SAW CUT WILL BE REQUIRED. THE EXPOSED EDGE SHALL BE "TACKED" WITH EMULSION PRIOR TO PAVING.
- IT IS THE RESPONSIBILITY OF THE CONTRACTOR TO KEEP DETAILED RECORDS OF MINOR CHANGES OR ADJUSTMENTS MADE DURING CONSTRUCTION (WHICH WERE NOT FORMALLY ISSUED). UPON PROJECT COMPLETION, THESE RECORDS AND/OR INFORMATION SHALL BE PROVIDED TO THE OWNER AND WARREN CONSULTING ENGINEERS, INC. UNLESS AN OFFICIAL "AS-BUILT" SET OF PLANS IS A REQUIREMENT OF THE CONTRACT. IF AS-BUILT PLANS ARE A REQUIREMENT OF THE CONTRACT, REFER TO SPECIFICATIONS FOR AS-BUILT DELIVERABLE REQUIREMENTS.
- IN VEHICULAR PATHWAYS, EXISTING ASPHALTIC AND/OR CONCRETE SURFACES SHALL BE CUT TO A NEAT AND STRAIGHT LINE, PARALLEL OR PERPENDICULAR TO THE VEHICULAR TRAVELED PATH. THIS IS TYPICALLY THE ROADWAY CENTERLINE, BUT MAY VARY. THAT SAWCUT EDGE SHALL BE PROTECTED FROM DAMAGE DURING CONSTRUCTION BY PATCHING OR PATCH BAGS FOR PATCH BAGS IF EDGE IS DAMAGED. A NEW SAW CUT WILL BE REQUIRED. THE EXPOSED EDGE SHALL BE "TACKED" WITH EMULSION PRIOR TO PAVING.
- NO BURNING OR BLASTING SHALL BE ALLOWED ONSITE UNLESS SPECIFICALLY ADDRESSED ON PLANS, OR SPECIFICALLY APPROVED AND COORDINATED WITH THE ARCHITECT, ENGINEER, AND LOCAL AGENCY OR OTHER ADMINISTRATIVE AUTHORITY.
- SUBGRADE AND RESULTING FINISHED GRADE SHALL BE CONSTRUCTED SMOOTH AND UNIFORM BETWEEN SPOT ELEVATIONS, CONTOURS OR OTHER STRUCTURE ELEVATIONS SHOWN ON GRADING OR OTHER PLANS. NO MOUNDS, RUTS, DEPRESSIONS OR OTHER GRADING DEFICIENCIES WILL BE ALLOWED UNLESS SPECIFICALLY SHOWN ON PLANS.
- ON NEW WATER SYSTEMS, SERVICE LATERALS SHALL BE MADE USING APPROPRIATE "TEE" AND "WYE" FITTINGS. SADDLE TAPS WILL ONLY BE ALLOWED WHEN MAKING CONNECTIONS TO EXISTING WATER MAINS.
- CURING COMPOUND SHALL BE APPLIED IN A CONTINUOUS SOLID WET FLOWING COAT. ANY "SPOTTY" APPLICATIONS SHALL BE RECOATED IMMEDIATELY. APPLICATION SHALL BE INSPECTED BY PROJECT INSPECTOR DURING APPLICATION.
- EMBEDMENT OF FEATURES IN CONCRETE PAVING, CURBS, OR WALLS, SUCH AS SQUARE OR ROUND TUBING, POSTS, OR COLUMNS, STEEL BOLTED PLATES, OR OTHER STRUCTURES, SHALL REQUIRE ADDITIONAL SCORE OR EXPANSION JOINTS TO PREVENT UNCONTROLLED CRACKING. THOSE ADDITIONAL JOINTS MAY OR MAY NOT BE SPECIFICALLY SHOWN ON PLANS BUT SHALL BE PROVIDED BY THE CONTRACTOR.
- EMBEDMENT OF FEATURES IN CONCRETE PAVING, CURBS, OR WALLS, SUCH AS SQUARE OR ROUND TUBING, POSTS, OR COLUMNS, STEEL BOLTED PLATES, OR OTHER STRUCTURES, SHALL REQUIRE A MINOR ADJUSTMENT OF REBAR WITHIN CONCRETE TO ALLOW FOR SUCH STRUCTURE. THAT REBAR ADJUSTMENT MAY NOT BE SPECIFICALLY SHOWN ON PLANS.
- NO MORE THAN 1 GALLON OF WATER PER YARD OF CONCRETE CAN BE ADDED TO THE TRUCK AFTER ARRIVAL TO PROJECT SITE. THE ADDITION OF WATER CAN ONLY BE ADDED UNDER THE SUPERVISION OF THE CONCRETE INSPECTOR OR LABORATORY TECHNICIAN.
- WHEN PUMPING CONCRETE FOR PLACEMENT, ABSOLUTELY NO WATER IS TO BE ADDED TO PUMP HOPPER. ANY WATER ADDED TO HOPPER WILL BE REASON FOR CONCRETE REJECTION AT THE CONTRACTORS EXPENSE.
- ALL CONTRACTION/CONSTRUCTION JOINTS "CJ" SHALL BE 1/4 THE SLAB THICKNESS DEEP, BUT NO LESS THAN 1" FOR CONTROLLING OF CRACKING. CONTRACTOR SHALL EXERCISE CAUTION WHEN FINAL TROWELING OF CONCRETE SO AS NOT TO FILL IN THESE JOINTS WITH CONCRETE GROUT. ANY CRACKS OUTSIDE OF JOINTS WHICH WERE CONSTRUCTED LESS THAN 1" DEEP, SHALL BE CAUSE FOR CONCRETE SLAB(S) TO BE REMOVED AND REPLACE AT CONTRACTORS EXPENSE.
- ANY SOREED BOARDS SET WITHIN CONCRETE SLABS SHALL BE AN "OVERHEAD SCREED" SO THERE IS NO INTERFERENCE WITH THE PLACEMENT AND ALIGNMENT OF SLAB REINFORCING.
- 3-1/2" FELT JOINTS WILL NOT BE ACCEPTED. PROVIDE A FULL 4" FELT JOINT FOR 4" SLAB CONSTRUCTION, AND A 6" FELT JOINT FOR A 6" SLAB CONSTRUCTION.
- SHOULD ANY SHRINKAGE CRACKS OCCUR OUTSIDE OF EITHER THE EXPANSION JOINTS OR CRACK CONTROL JOINTS, THEN THE CONCRETE SLAB SHALL BE SAWCUT AT THE NEAREST JOINTS ON EACH SIDE OF THE CRACK AND THE CONCRETE SECTION SHALL BE, REMOVED AND REPLACED. NEW CONCRETE SHALL BE DOWELED INTO EXISTING CONCRETE PER DRAWING DETAIL.
- ALL AREAS DISTURBED BY GRADING OPERATIONS WHETHER SHOWN ON THE DRAWINGS OR NOT SHALL BE HYDRO SEEDED UNLESS OTHERWISE NOTED. HYDRO SEEDING SHALL CONFORM TO LOCAL CITY/COUNTY STANDARDS.
- REPAIR OR PATCHING OF GALVANIZED METALS, SUCH AS AFTER WELDING GALVANIZED COMPONENTS, SHALL BE MADE USING A ZINC COMPOSITION "HOT STICK" APPLICATION PER ASTM A 780-01. GALVANIZING PAINTS WILL NOT BE ALLOWED.

GENERAL PAVING SURFACE NOTES:

- PROVIDE EQUIVALENT OF MEDIUM BROOM FINISH AT SLOPES UP TO 5.99%, TYPICAL PROVIDE EQUIVALENT OF HEAVY BROOM FINISH AT SLOPES 6% AND GREATER. REFER TO SPECIFICATIONS.
- ALL NEW PEDESTRIAN WALKWAYS (NON-RAMP) SHALL BE SLOPED NO GREATER THAN 2.0%, AND NO LESS THAN 0.75% IN ANY DIRECTION UNLESS SPECIFICALLY LABELED OTHERWISE. ALL CONCRETE SHALL MEET THE FOLLOWING SLOPE REQUIREMENTS:
 - NO GREATER THAN 5% SLOPE IN THE DIRECTION OF TRAVEL.
 - NO GREATER THAN 2% SLOPE CROSSING THE DIRECTION OF TRAVEL.
 - NO GREATER THAN 2% SLOPE IN ANY DIRECTION IN COURTYARD OR PLAZA AREAS.

CIVIL SHEET INDEX

- C0.1 CIVIL GENERAL NOTES AND ABBREVIATIONS
- C1.1 DEMOLITION, GRADING AND PAVING PLAN

LANDSCAPE/IRRIGATION NOTE:
 GENERAL CONTRACTOR IS REQUIRED TO HIRE A LANDSCAPE SUBCONTRACTOR TO PERFORM ALL LANDSCAPE AND IRRIGATION REPAIRS.

SHADE STRUCTURE AT ALICE BIRNEY PUBLIC WALDORF K-8 SCHOOL
 SACRAMENTO CITY UNIFIED SCHOOL DISTRICT
 SACRAMENTO, CA

811 Know what's below. Call before you dig.

rga+ A studio of HMC Architects

REGISTERED PROFESSIONAL ENGINEER
 ANTHONY J. TASSANO
 NO. C74690
 STATE OF CALIFORNIA

WARREN CONSULTING ENGINEERS, INC.
 1117 WINDFIELD WAY, SUITE 110
 EL DORADO HILLS, CA 95762 | (916) 985-1870

Copyright © 2021 Rainforth Grau Architects. All rights reserved.
 Reproduction of these plans, either in whole or in part, including any form of copying and/or preparation of derivative works thereof, for any reason without prior written permission, is strictly prohibited.

CIVIL GENERAL NOTES AND ABBREVIATIONS

PROJECT NO. 21-1504.01
 DATE: 4/29/22
 SHEET C0.1



DEMOLITION PLAN

SCALE: 1"=10'

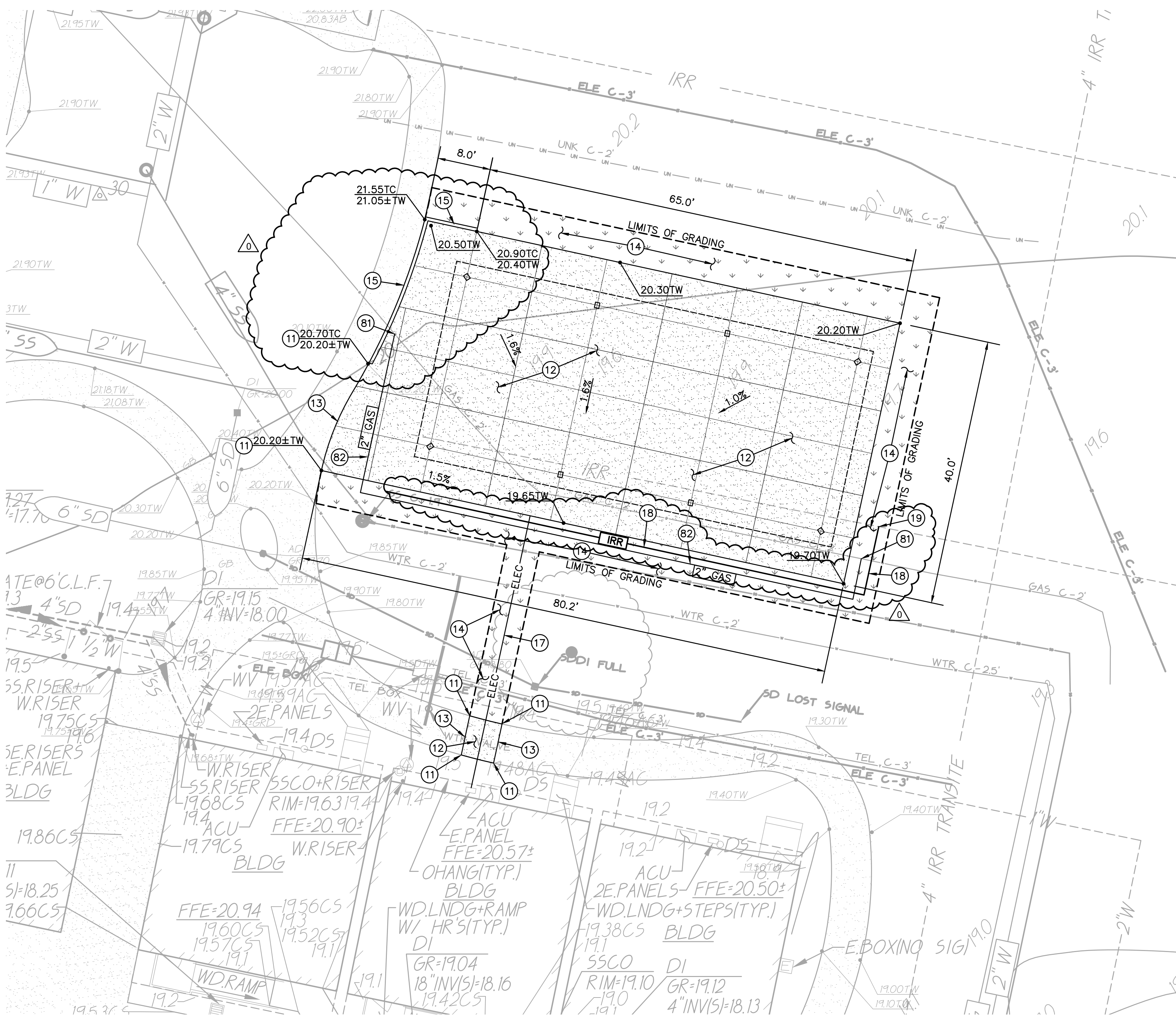

GRADING AND PAVING PLAN

SCALE: 1"=10'

- DEMOLITION NOTES**
1. REMOVE AND DISPOSE OF EXISTING TREE/SHRUBS, TRUNK AND ASSOCIATED ROOTS.
 2. REMOVE AND DISPOSE OF EXISTING LANDSCAPING, TURF AND ASSOCIATED IRRIGATION PIPING/SPRINKLERS WITHIN AREAS OF WORK. CUT AND GAP ANY MAINLINES NEAR WHERE THEY ENTER THE BOUNDARY OF THE PROJECT. MARK ALL CAPPED LINES WITH AN IRRIGATION VALVE BOX. ALL EXISTING IRRIGATION AREAS OUTSIDE THE PROJECT WORK AREA SHALL BE PRESERVED AND OPERATIONAL. INTEGRITY SHALL BE MAINTAINED WITH PROPER SPRINKLER COVERAGE TO TURF AREAS TO REMAIN.
 3. SAWCUT, REMOVE AND DISPOSE OF EXISTING CONCRETE PAVING TO NEAREST JOINT AND ASSOCIATED AGGREGATE BASE TO ALLOW FOR ELECTRICAL TRENCH INSTALLATION. SAWCUT SHALL BE A NEAT STRAIGHT LINE, MAINTAIN CLEAN, STRAIGHT CUT EDGE UNTIL NEW PAVING IS PLACED.
 4. REMOVE AND DISPOSE OF EXISTING GAS PIPE TO EXTENT SHOWN.
 5. REMOVE AND DISPOSE OF EXISTING IRRIGATION PIPE TO EXTENT SHOWN.

SUBGRADE PREPARATION

1. FOLLOWING SITE DEMOLITION ACTIVITIES:
EXCAVATE DOWN TO ROUGH SUBGRADE ELEVATION. SCARIFY THE EXISTING SOILS TO A MINIMUM DEPTH OF 12 INCHES. MOISTURE CONDITION TO AT LEAST 2 PERCENT ABOVE THE OPTIMUM MOISTURE AND COMPACT TO AT LEAST 90 PERCENT OF THE MAXIMUM DRY DENSITY DETERMINED BY THE ASTM D1557 TEST METHOD.

GRADING NOTES

11. MATCH EXISTING GRADE/ELEVATION.
12. CONSTRUCT CONCRETE SIDEWALK PER PLACE 5" PCC WITH #4 REBAR AT 24" O.C.E.W. OVER 12" CL2 AGGREGATE BASE ON COMPACTED SUBGRADE.
13. DOWEL INTO EXISTING CONCRETE PER (1) C1.1
14. PLACE SOD IN ALL AREAS DISTURBED BY CONSTRUCTION ACTIVITIES THAT ARE NOT TO RECEIVE PAVEMENT. PROVIDE NEW SPRINKLER HEADS AND PIPING AS REQUIRED TO ACHIEVE PROPER COVERAGE.
15. CONSTRUCT CONCRETE CURB PER (2) C1.1
16. NOT USED.
17. REFER TO ELECTRICAL PLANS FOR CONDUIT PLACEMENT AND DETAILING.
18. PLACE IRRIGATION PIPE. SIZE TO MATCH EXISTING LINE SIZE. PLACE SPRINKLER HEADS AS REQUIRED TO MAINTAIN COVERAGE.
19. CONNECT TO EXISTING IRRIGATION PIPE. PROVIDE ALL FITTINGS NECESSARY TO MAKE CONNECTION.

GAS NOTES

81. CONNECT TO EXISTING GAS. FIELD VERIFY DEPTH AND LOCATION PRIOR TO TRENCHING.
82. PLACE 2" GAS LINE PER (3) C1.1

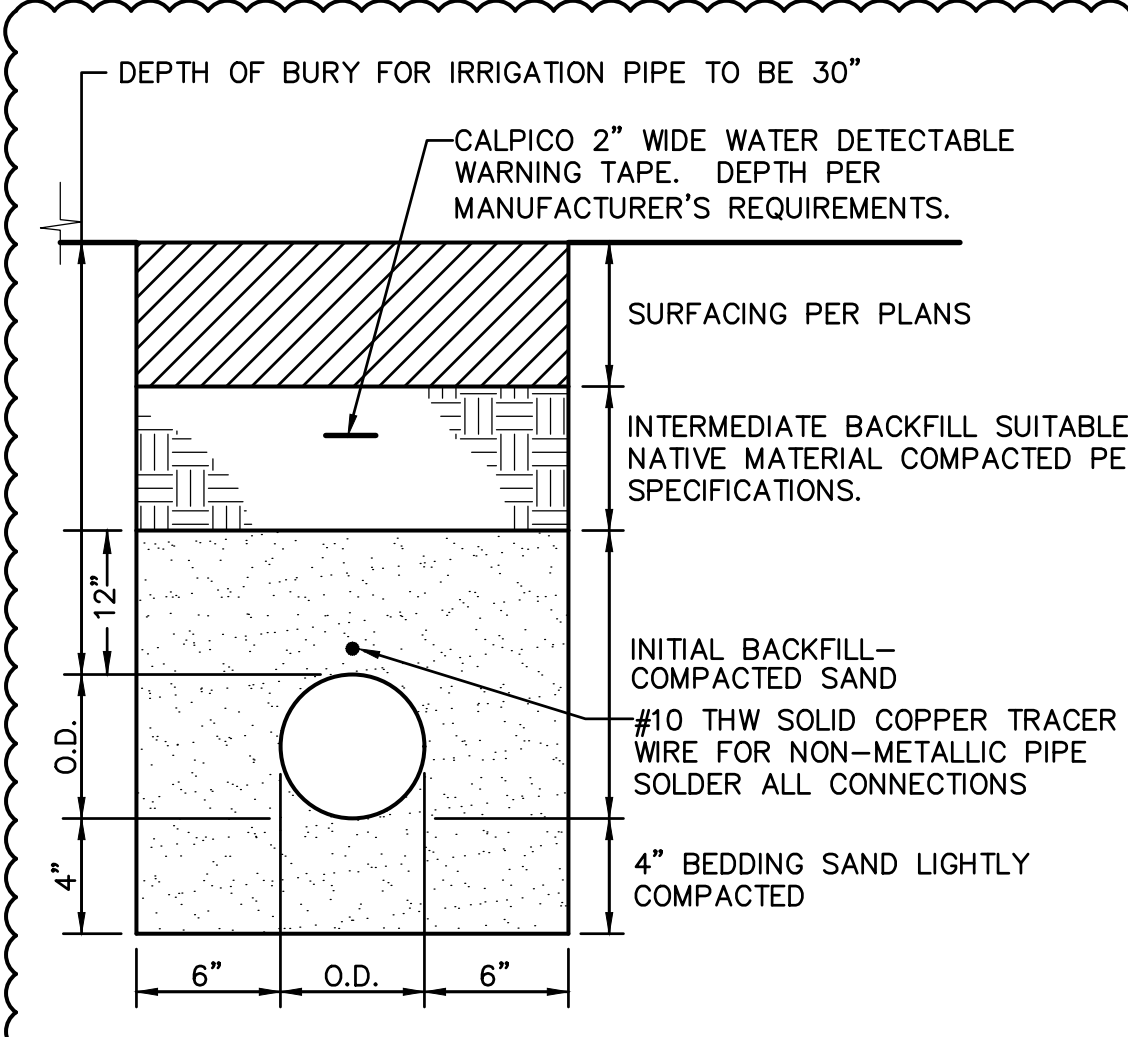

4 WATER TRENCH NO SCALE

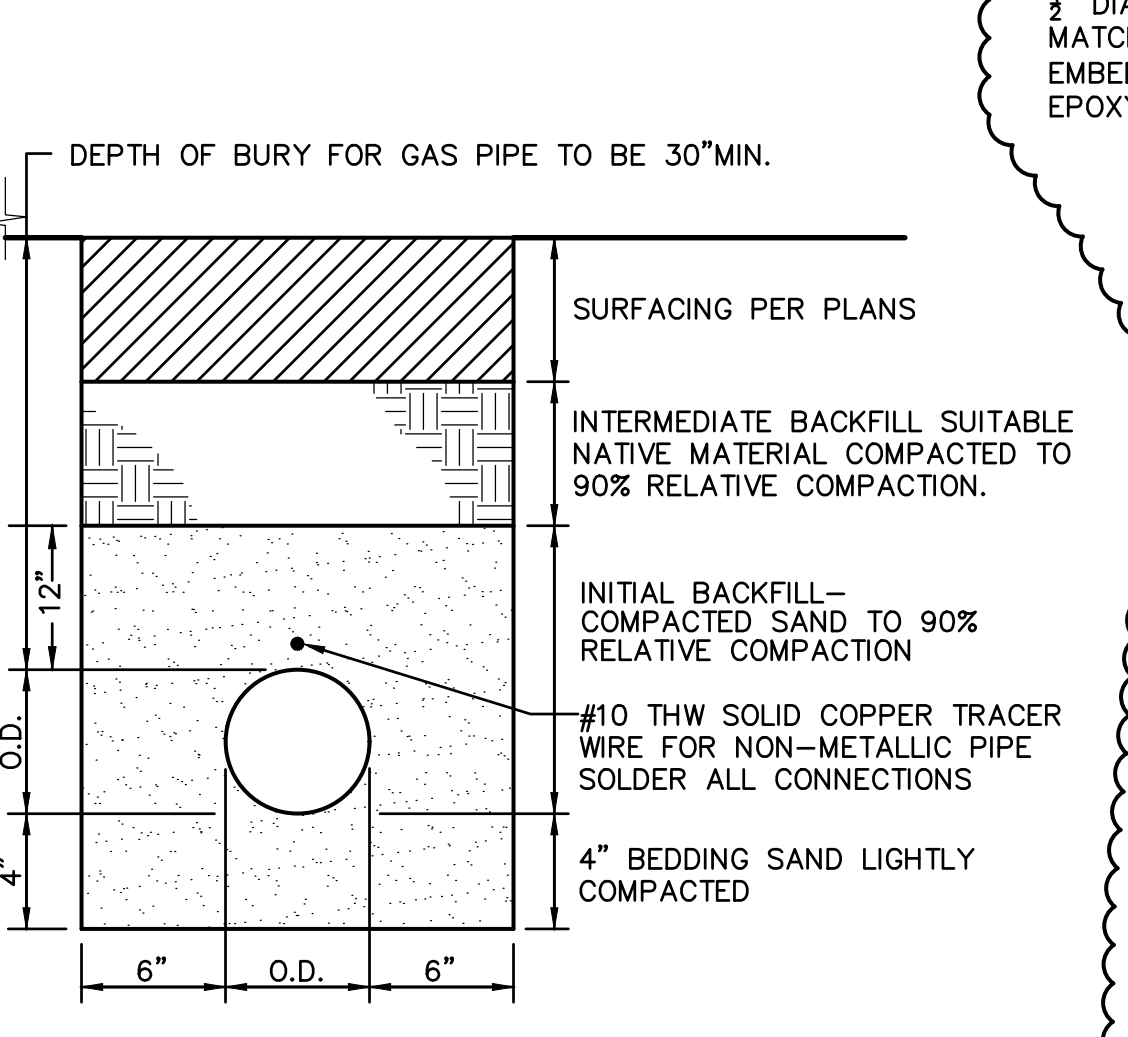

3 GAS TRENCH NO SCALE

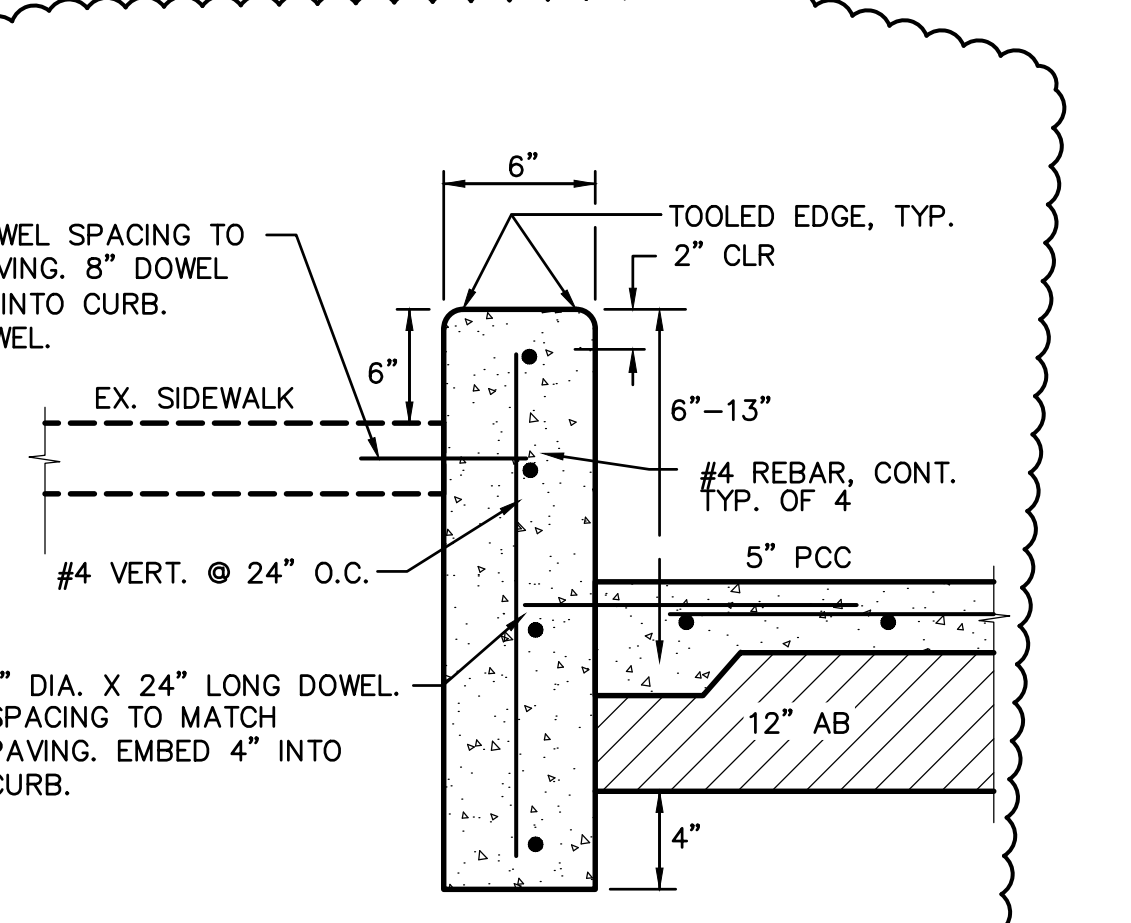

2 CONCRETE CURB NO SCALE

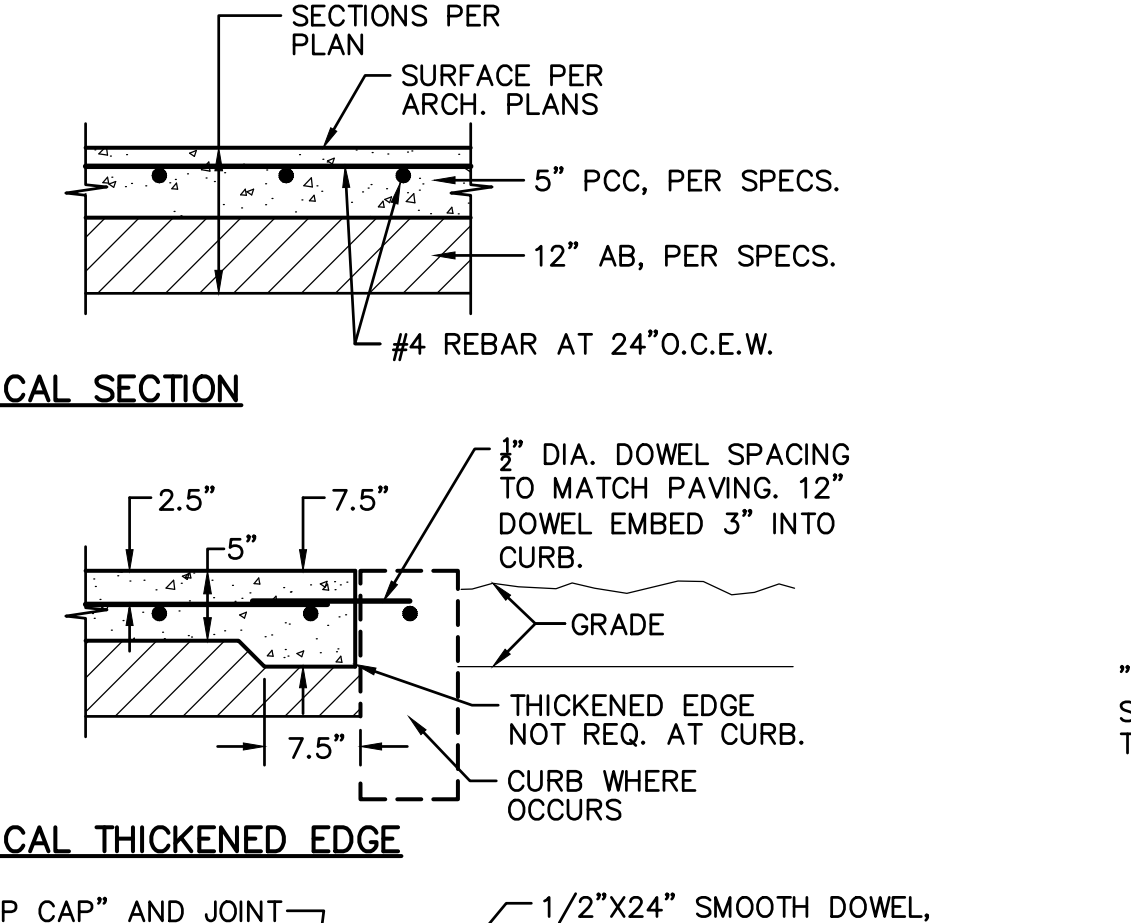

1 CONCRETE SIDEWALK NO SCALE

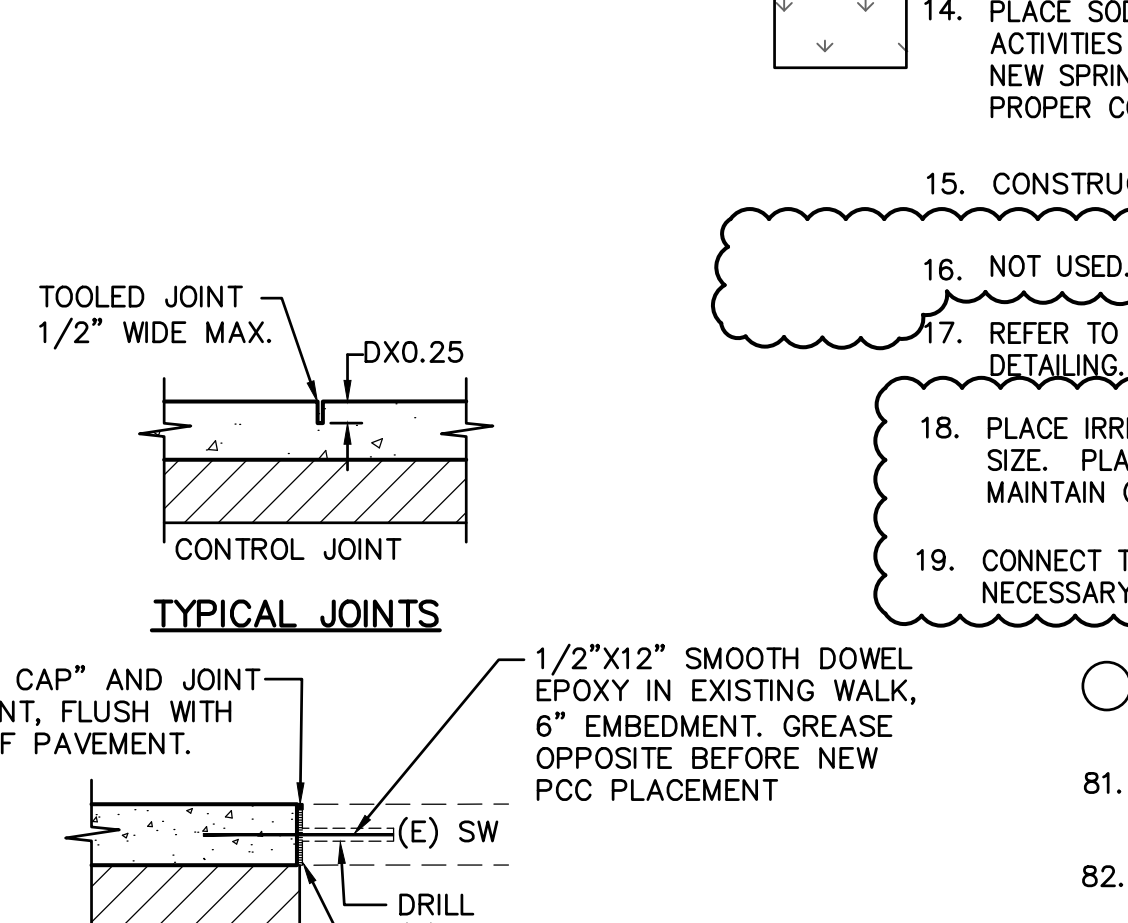

CONNECTION TO (E) CONCRETE NO SCALE

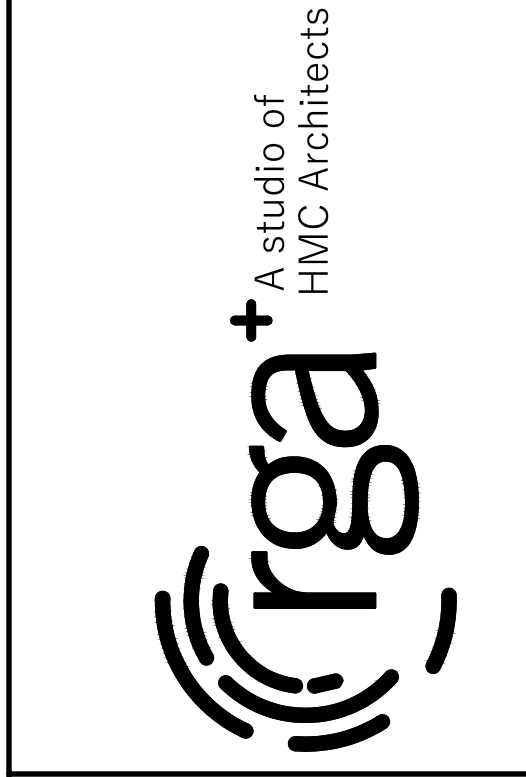
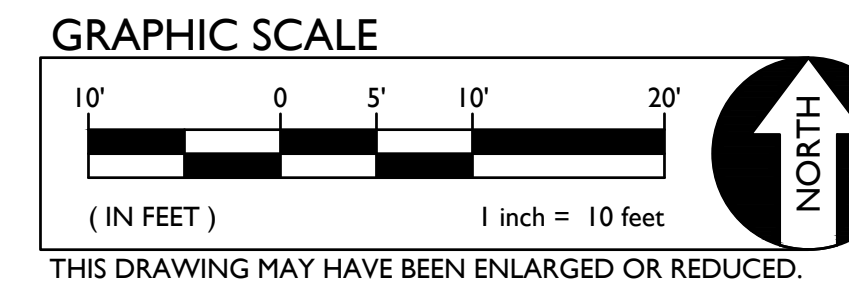

SHADE STRUCTURE AT ALICE BIRNEY PUBLIC WALDORF K-8 SCHOOL
SACRAMENTO CITY UNIFIED SCHOOL DISTRICT
SACRAMENTO, CA

Copyright © 2021 Rainforth Grau Architects. All rights reserved. Reproduction of these plans, either in whole or in part, including any form of copying and/or preparation of derivative works thereof, for any reason without prior written permission, is strictly prohibited.

DEMOLITION, GRADING AND PAVING PLAN

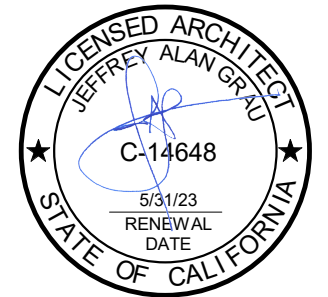
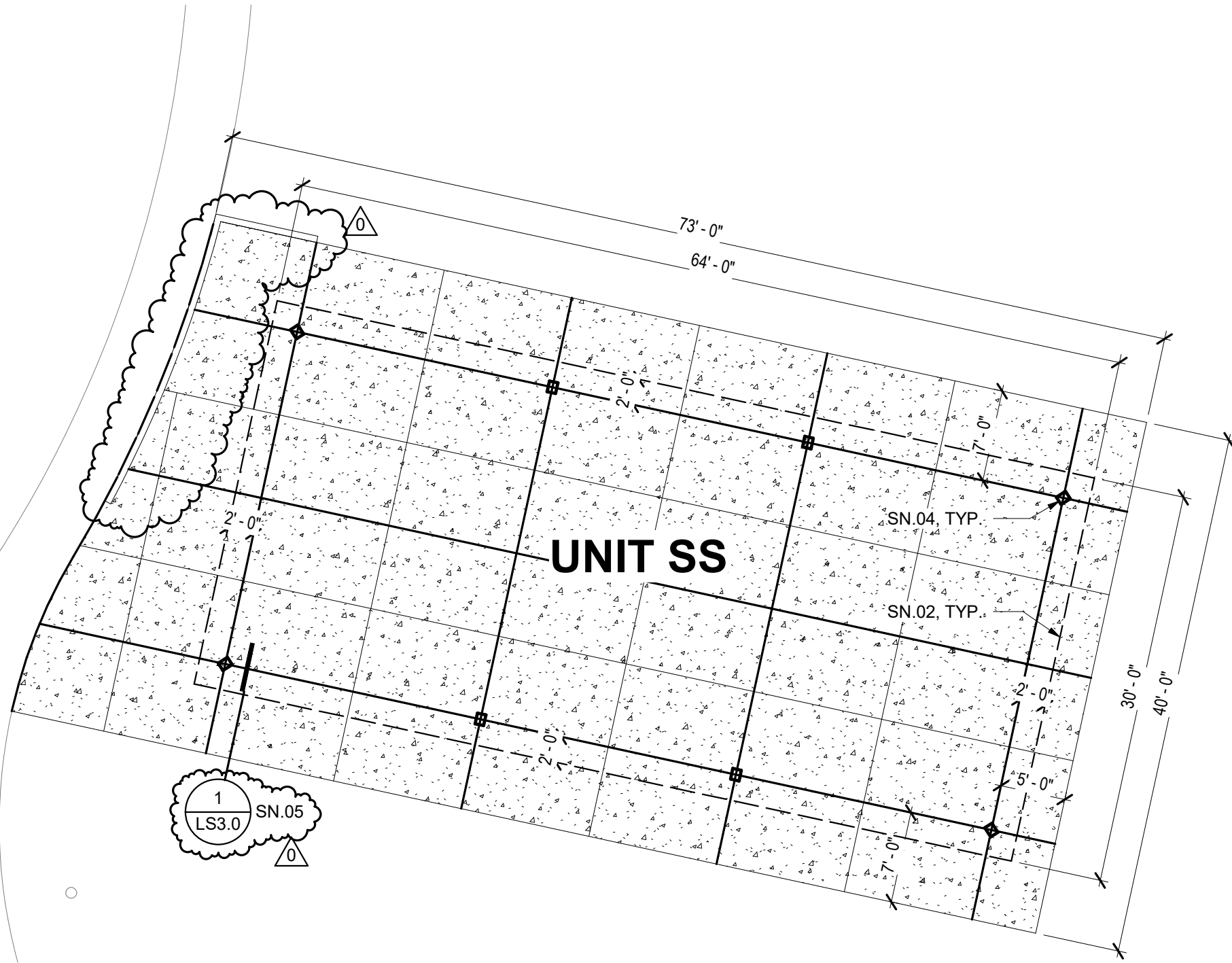

2 ENLARGED SITE PLAN - SHADE STRUCTURE
1" = 10'-0"

ADDENDUM 0

ALL FEATURES, NOTES AND DIMENSIONS NOT SPECIFICALLY SHOWN OR NOTED AS CHANGED SHALL REMAIN AS SHOWN ON PREVIOUSLY ISSUED DOCUMENTS.



ENLARGED PLAN **A1.1.1**
 SHADE STRUCTURE AT ALICE BIRNEY PUBLIC
 WALDORF K-8 SCHOOL
 SACRAMENTO CITY UNIFIED SCHOOL DISTRICT
 SACRAMENTO, CA
 DSA APP.02-119978

DATE: 04/29/22
 PROJECT NO.: 21-1504.01
 SHEET: **AD0.03**



SHEET NOTES:

1. ALL EXISTING EQUIPMENT, DEVICES, CONDUIT AND WIRING, ETC., SHOWN ON PLANS ARE BASED ON AVAILABLE EXISTING DRAWINGS AND LIMITED SITE SURVEYS, AND SHOWN FOR CLARITY ONLY.
2. SEE ONE LINE DIAGRAM AND PANEL SCHEDULE ON SHEET E2.1 FOR REFERENCE.

KEYED NOTES:

1. PROVIDE TRENCH FOR 24 INCH MINIMUM COVER. LOCATE AND PROTECT (E) UTILITIES, I.E. IRRIGATION, SEWER, DRAINAGE PIPES, ETC. PROVIDE SAND TO COVER CONDUIT TO SIX(6) INCHES, THEN ADD TRACER TAPE. COMPLETE BACKFILL TO GRADE, COMPACTING IN SIX(6)-INCH LIFTS. FINISH TO MATCH EXISTING. SEE DETAIL 3/E3.1.
2. DROP CONDUIT BELOW GRADE AND TRENCH TO SHADE LOCATION, RUNNING CONDUIT TO INTERCEPT THE CHRISTY BOX ALONG THE WAY. PAINT EXPOSED CONDUIT TO MATCH (E) FINISH.
3. PROVIDE AT MINIMUM TWO(2) GROUND RODS, ONE AT THE PULL BOX AND ONE NEAR THE CORNER POST OF THE SHADE STRUCTURE, EACH 5/8" BY TEN(10) FEET LONG, CU, AT LEAST TEN(10) FEET APART. BOND TO METAL OF SHADE STRUCTURE. SEE DETAILS 5/E3.1 AND 2/E3.1.
4. LOCKABLE, WEATHERPROOF RECEPTACLE TO HAVE A TWO-GANG BACK BOX WITH 1" THREADED PORT(S). MOUNT RECEPTACLES 36" ABOVE GRADE UNLESS SPECIFIED OTHERWISE. SEE DETAIL 4/E3.1.
5. PROVIDE CHRISTY B1324 PULL BOX WITHIN FIVE(5) FT OF SHADE STRUCTURE. CHRISTY BOX TO HAVE HOLD DOWN BOLTS AND BE LABELED FOR POWER. SEE DETAIL 2/E3.1.
6. RUN CONDUIT BELOW SHADE STRUCTURE CONCRETE PAD.
7. SAW CUT AND PATCH BACK (E) CONCRETE AS REQUIRED FOR TRENCHING.

irga+ A studio of HMC Architects

PETERS engineering
 7750 College Town Dr. ste.101
 Sacramento, CA 95826
 Tel (916) 447-2841
 www.peterseng.com
 Job no. 22.010
 consulting mechanical and electrical engineers

PROFESSIONAL ENGINEER
 17247
 Exp. 6/30/22
 ELECTRICAL
 STATE OF CALIFORNIA
 PLOT DATE: 4/26/2022

SHADE STRUCTURE AT ALICE BIRNEY PUBLIC WALDORF K-8 SCHOOL

SACRAMENTO CITY UNIFIED SCHOOL DISTRICT
 SACRAMENTO, CA

Revision	
ADDENDUM	4/29/22

Copyright © 2021 Rainforth Grau Architects. All rights reserved. Reproduction of these plans, either in whole or in part, including any form of copying and/or preparation of derivative works thereof, for any reason without prior written permission, is strictly prohibited.

SITE PLAN - ELECTRICAL

PROJECT NO. 21-1504.01
 DATE: 4/29/22
 SHEET

E1.1
AD0.04

1 SITE PLAN - ELECTRICAL
 SCALE: 1"=20'

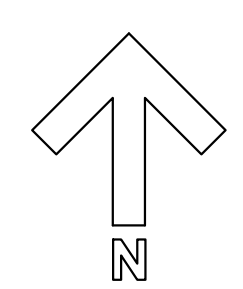

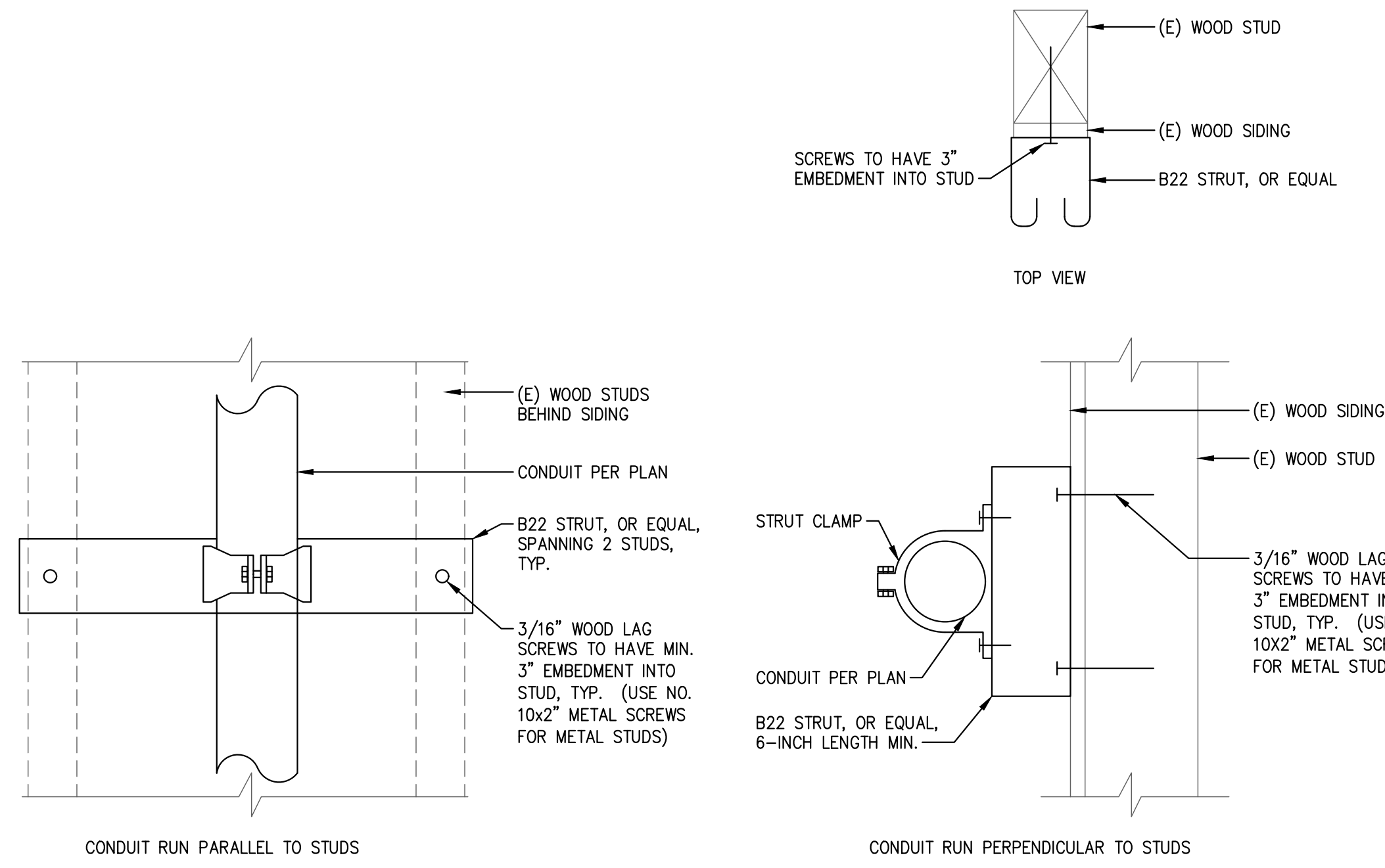

- NOTES:
- CONDUIT SHALL BE SUPPORTED AT INTERVALS NOT EXCEEDING TEN(10) FEET AND NOT MORE THAN THREE(3) FEET FROM THE OUTLET AND AT ANY POINT WHERE IT CHANGES DIRECTION.
 - PERFORATED STRAP AND PLUMBER'S TAPE SHALL NOT BE PERMITTED.
 - MAXIMUM CONDUIT AND CONDUCTOR WEIGHT IS 1.83LBS PER LINEAR FOOT.

7 CONDUIT MOUNTING DETAIL - STUD WALLS

SCALE: NONE

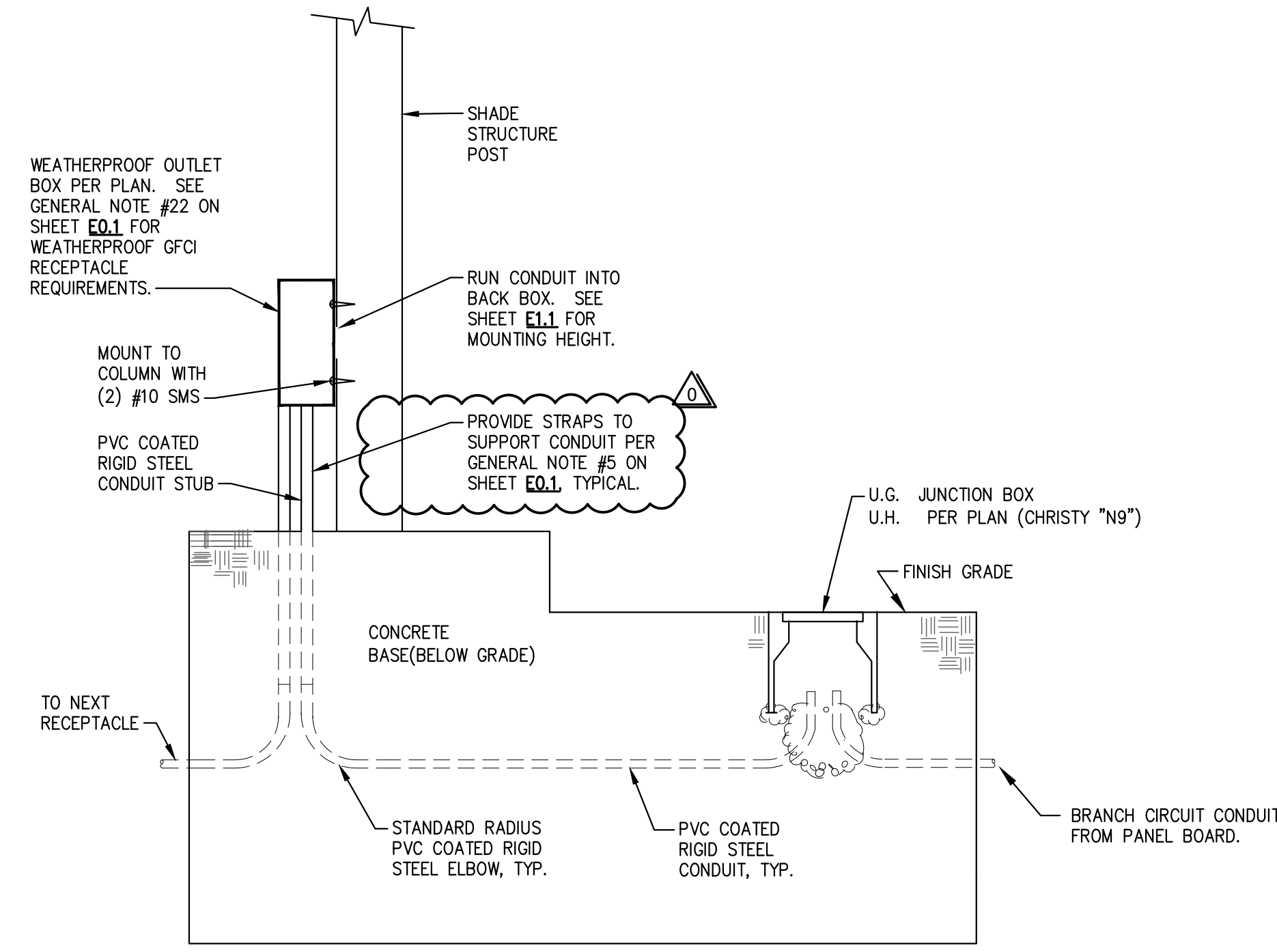

4 CONDUIT STUB IN POST DETAIL

SCALE: NONE

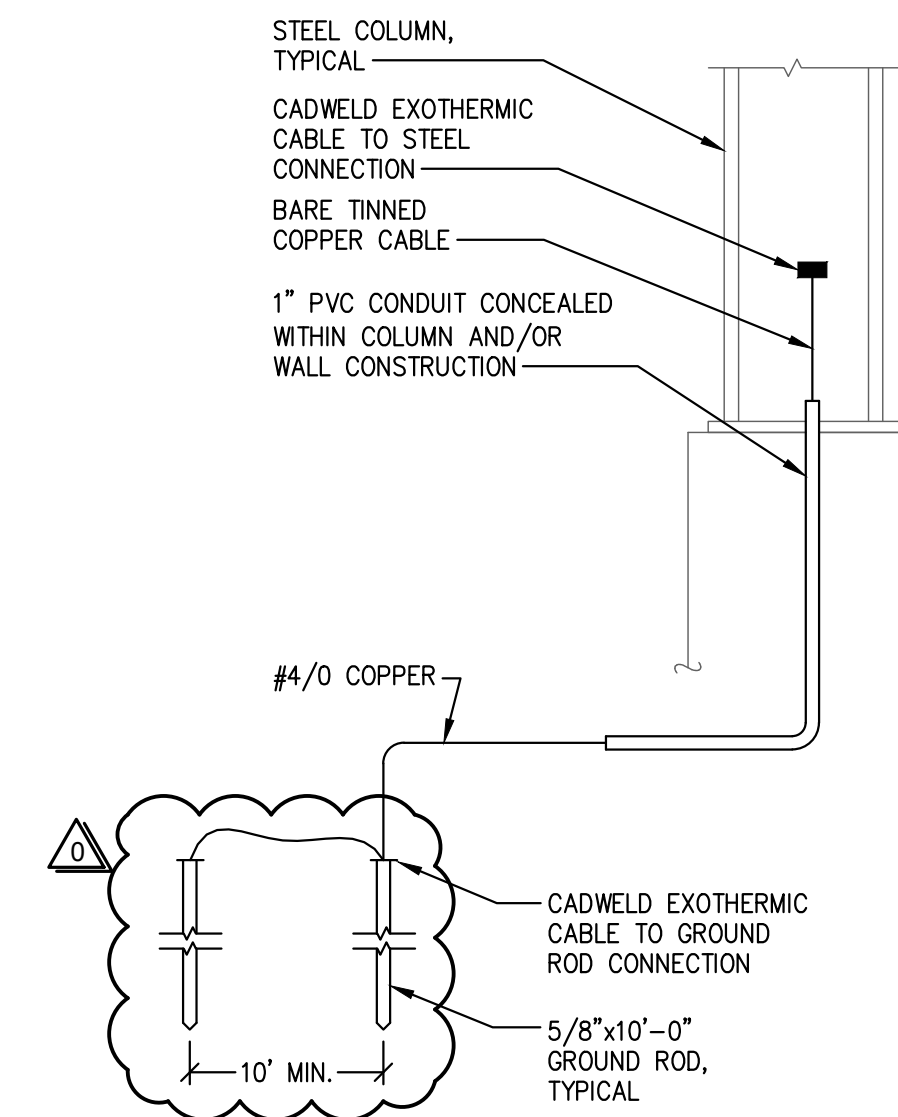

- NOTES:
- ALL GROUNDING CONNECTIONS SHALL BE IN CONFORMANCE WITH N.E.C. ARTICLE 250.
 - FOR ALL ADDITIONAL REQUIREMENTS REFER TO SPEC SECTIONS 26 05 10.

5 TYPICAL STEEL COLUMN & REBAR GROUNDING DETAIL

SCALE: NONE

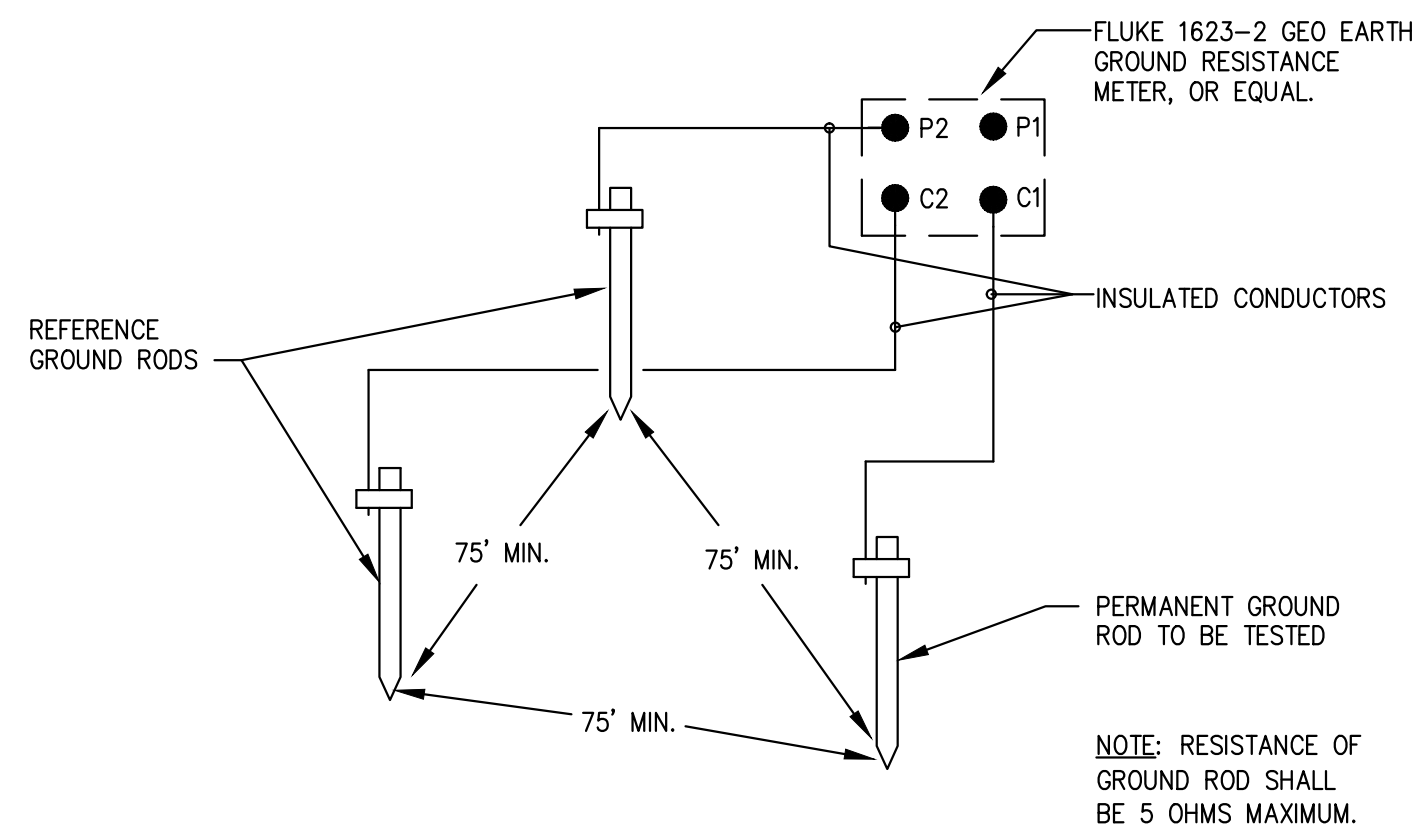

- FALL OF POTENTIAL TEST METHOD NOTES:
- POWER EQUIPMENT OR SYSTEMS WITH CAPACITY OF 500KVA OR LESS: 10 OHMS.
 - POWER EQUIPMENT OR SYSTEMS WITH CAPACITY OF 500 TO 1000KVA: 5 OHMS.
 - POWER EQUIPMENT OR SYSTEMS WITH CAPACITY GREATER THAN 1000KVA: 3 OHMS.
 - POWER DISTRIBUTION UNITS OR PANELBOARDS SERVING ELECTRONIC LT. EQUIPMENT: 3 OHMS.
 - MAN-HOLE GROUNDS: 10 OHMS.
- FALL OF POTENTIAL 3-POINT TEST: GROUND RING, I.E. 10 BY 10 RING, 14' DIAGONAL LENGTH ISOLATION FROM UTILITY NEUTRAL PROBE Z IS DRIVEN A DISTANCE OF 10 TIMES DIAGONAL LENGTH OF THE GROUNDING ROD SYSTEM (ROD X). A SECOND PROBE (Y) IS PLACED IN LINE AT A DISTANCE FROM ROD X EQUAL TO THE DIAGONAL LENGTH OF THE GROUNDING SYSTEM.

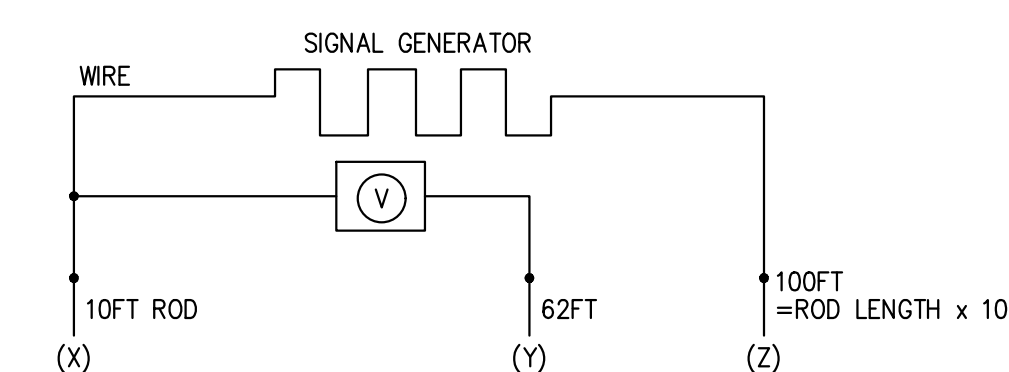

AT THIS POINT, A KNOWN CURRENT IS APPLIED ACROSS X & Z, WHILE THE RESULTING VOLTAGE IS MEASURED ACROSS X & Y. OHMS LAW APPLIED $R=V/I$. THEN (Y) MOVED TO 2 TIMES THE DIAGONAL LENGTH, THEN MOVE OUT TO 3 TIMES(3X), 4X, ... 9X THE DIAGONAL LENGTH TO COMPLETE THE 3 POINT TEST WITH A TOTAL OF NINE RESISTANCE MEASUREMENTS.

6 METHOD OF TESTING GROUND RODS DETAIL

SCALE: NONE

1 DETAIL REMOVED

SCALE: NONE

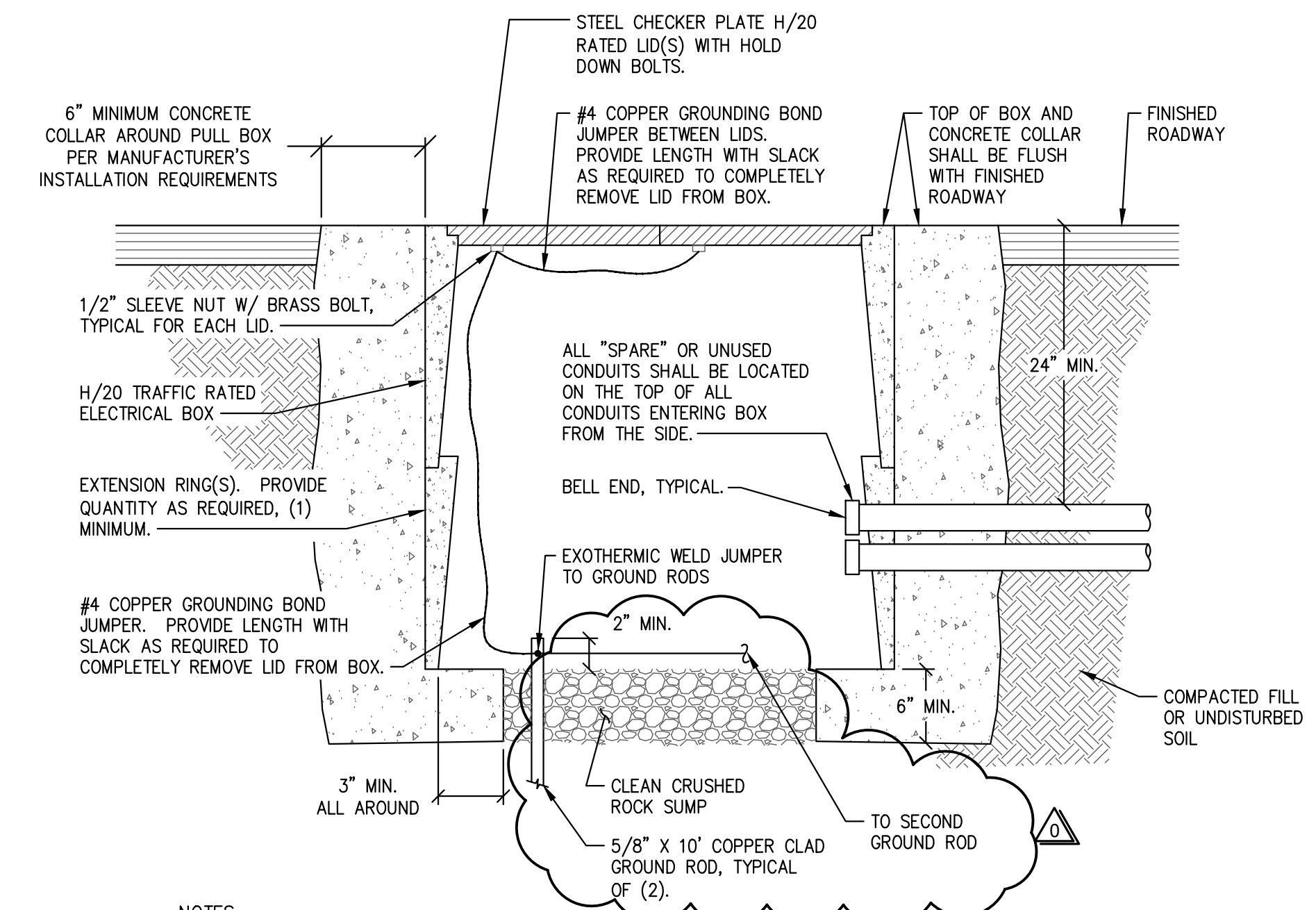

- NOTES:
- PROVIDE H/20 TRAFFIC RATED BOXES IN ALL LOCATIONS WITH VEHICLE TRAFFIC
 - CONTRACTOR SHALL PROVIDE THE MANUFACTURER'S INSTALLATION INSTRUCTIONS FOR H/20 TRAFFIC RATING REQUIREMENTS AS PART OF THE SUBMITTALS.

2 TYPICAL H/20 TRAFFIC RATED PULL BOX

SCALE: NONE

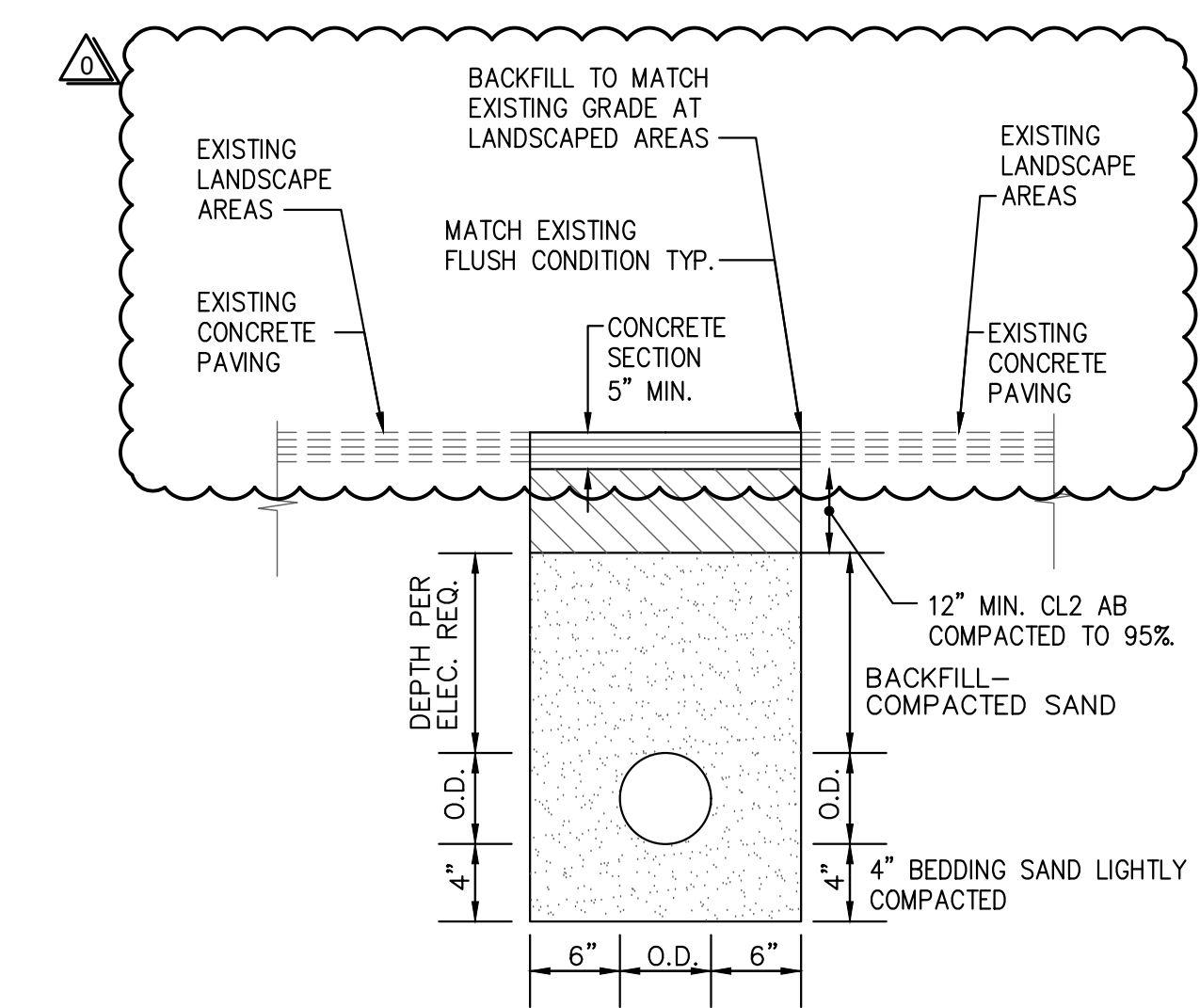

3 TYPICAL TRENCH DETAIL

SCALE: NONE

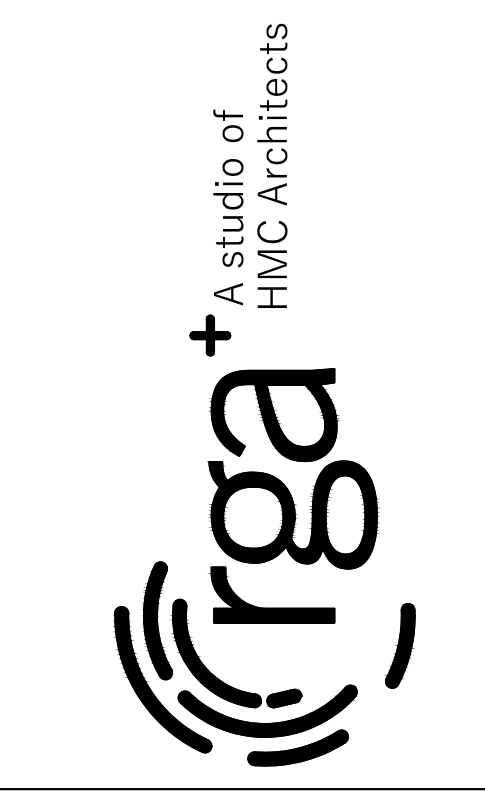

PETERS engineering
7750 College Town Dr. ste.101
Sacramento, CA 95826
Tel (916) 447-2841
www.peterseng.com
Job no. 22.010
consulting mechanical and electrical engineers

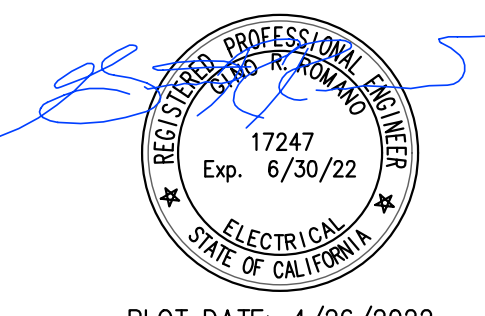

PLOT DATE: 4/26/2022

SHADE STRUCTURE AT ALICE BIRNEY PUBLIC WALDORF K-8 SCHOOL
SACRAMENTO CITY UNIFIED SCHOOL DISTRICT
SACRAMENTO, CA

Revision	
ADDENDUM	4/29/22

Copyright © 2021 Rainforth Grau Architects. All rights reserved. Reproduction of these plans, either in whole or in part, including any form of copying and/or preparation of derivative works thereof, for any reason without prior written permission, is strictly prohibited.

DETAILS

PROJECT NO. 21-1504.01
DATE: 4/29/22
SHEET

E3.1

AD0.05

Statement of General Conformance

THE FOLLOWING DRAWINGS OR SHEETS LISTED ON THE COVER OR INDEX SHEET HAVE BEEN PREPARED BY OTHER DESIGN PROFESSIONALS OR CONSULTANTS WHO ARE LICENSED AND/OR AUTHORIZED TO PREPARE SUCH DRAWINGS IN THIS STATE. IT HAS BEEN EXAMINED BY ME FOR:

- 1) DESIGN INTENT AND APPEARS TO MEET THE APPROPRIATE REQUIREMENTS OF TITLE 24, CALIFORNIA CODE OF REGULATIONS AND THE PROJECT SPECIFICATIONS PREPARED BY ME, AND
- 2) COORDINATION WITH MY PLANS AND SPECIFICATIONS AND IS ACCEPTABLE FOR INCORPORATION INTO THE CONSTRUCTION OF THIS PROJECT.

THE STATEMENT OF GENERAL CONFORMANCE "SHALL NOT BE CONSTRUED AS RELIEVING ME OF MY RIGHTS, DUTIES, AND RESPONSIBILITIES UNDER SECTIONS 17302 AND 81138 OF THE EDUCATION CODE AND SECTIONS 4-336, 4-341, AND 4-344" OF TITLE 24, PART 1. (TITLE 24, PART 1, SECTION 4-317 (b))



SIGNATURE

4/21/22

DATE

ARCHITECT OR ENGINEER DESIGNATED TO BE IN GENERAL RESPONSIBLE CHARGE

Jeffrey Grau

PRINT NAME

C-14648 05/31/23

LICENSE NUMBER EXPIRATION DATE

LIST COMPLETELY, ITEMS REVIEWED AND ACCEPTED:

PC SHADE STRUCTURE

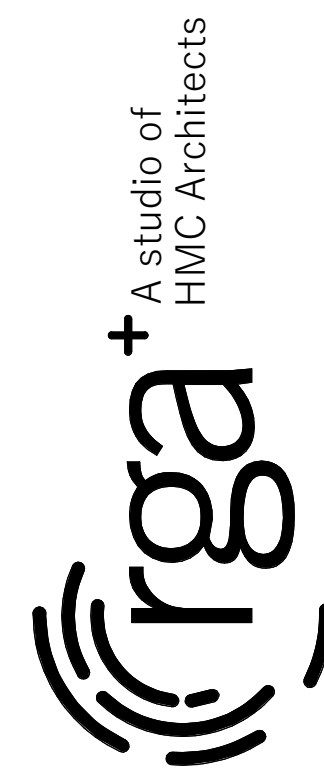
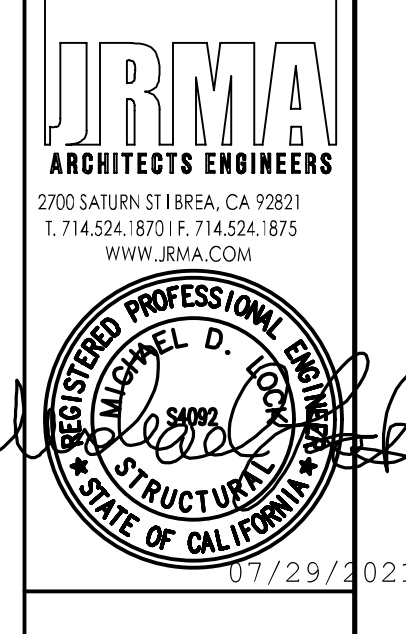
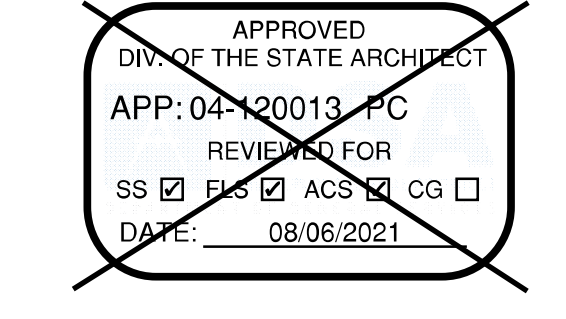

Table with columns: ICON STD, R4/DSA-PC, DRAWN BY, ANGEL, DATE, 4/2/2021, REV, REV DATE



03/29/2021



SHADE STRUCTURE AT ALICE BIRNEY PUBLIC WALDORF K-8 SCHOOL

SACRAMENTO CITY UNIFIED SCHOOL DISTRICT SACRAMENTO, CA

Revision

GENERAL INFO

PROJECT NO. 21-1504.01 DATE: 4/7/21 SHEET LS1.0

AD0.07

DESIGN CRITERIA table with columns: DESCRIPTION, DESIGN VALUES. Includes sections for DEAD AND LIVE LOADS, WIND DESIGN, SEISMIC DESIGN, and FLOOD DESIGN.

GENERAL. 1. GENERAL NOTES AND TYPICAL DETAILS SHALL APPLY TO ALL PARTS OF THE JOB EXCEPT WHERE THEY MAY CONFLICT WITH DETAILS AND NOTES ON OTHER SHEETS...

REINFORCING STEEL. 1. REINFORCING STEEL SHALL BE DEFORMED STEEL CONFORMING TO THE REQUIREMENTS OF ASTM A-615, AS FOLLOWS: GR 60: (#4 BARS AND LARGER) GR 40: (#3 BARS)...

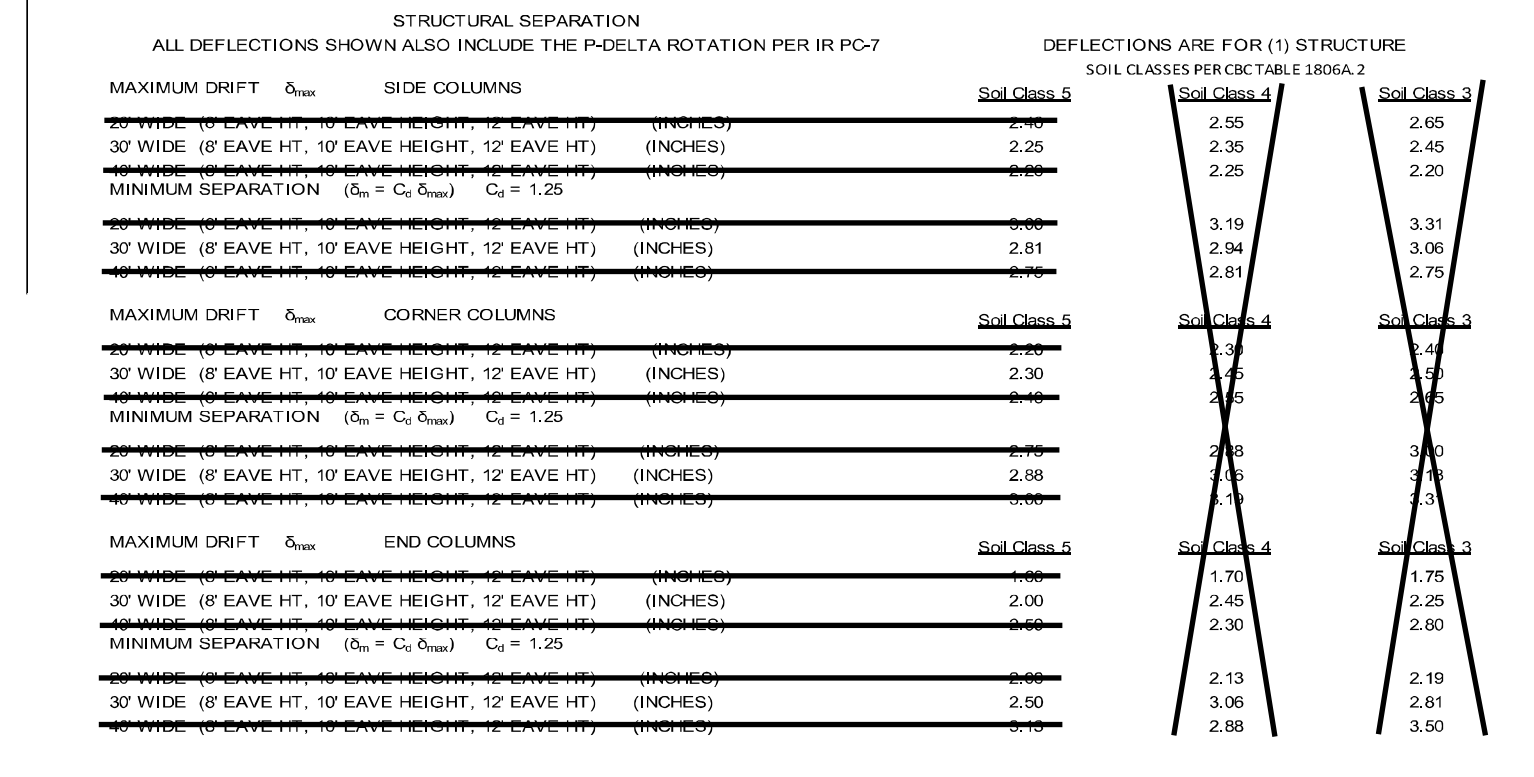

STRUCTURAL AND MISCELLANEOUS STEEL. 1. ALL STRUCTURAL STEEL SHALL BE DETAILED, FABRICATED AND ERECTED IN ACCORDANCE WITH THE AMERICAN INSTITUTE OF STEEL CONSTRUCTION (AISC) SPECIFICATION MANUAL...

Table with columns: STRENGTH Pz (28 DAYS), W/C RATIO (NON-AIR ENTRAINED), W/C RATIO (AIR ENTRAINED), SLUMP (in), UNIT WEIGHT (NORMAL WEIGHT). Includes concrete mix design parameters.

ARCHITECTURAL REQUIREMENTS table with columns: DESCRIPTION, DESIGN VALUES. Includes construction type, occupancy classification, and fire sprinkler system.

INSTRUCTIONS FOR ARCHITECTS SUBMITTING THESE PRE-CHECKED DRAWING TO DSA: BEFORE SUBMITTING THESE PRE-CHECKED DRAWINGS FOR YOUR PROJECT, FOLLOW THE STEPS BELOW TO PROPERLY DEFINE THE APPROVED OPTIONS:

Table for STEP 1: IDENTIFY PROJECT NAME AND SCHOOL DISTRICT. Includes fields for PROJECT NAME, SCHOOL DISTRICT, and SHADING STRUCTURE AT ALICE BIRNEY PUBLIC WALDORF K-8 SCHOOL.

RELATED BUILDING CODES AND STANDARDS. TITLE 24 CODES: 2019 CALIFORNIA ADMINISTRATIVE CODE (CAC) (PART 1, TITLE 24, CCR)...

Table for STEP 2: SELECT FRAME DIMENSIONS FOR YOUR PROJECT. Includes columns for FRAME WIDTH, FRAME LENGTH, and suggested/other options.

Table for STEP 3: IDENTIFY THE Ss ACCELERATION (g) FOR YOUR PROJECT. Includes columns for Ss REGION, Ss REGIONS, and MAX DEAD LOAD.

REFERENCE CODE SECTIONS FOR APPLICABLE STANDARDS: 2019 CBC, CHAPTER 35; 2019 CFC, CHAPTER 80.

Table for STEP 4: IDENTIFY THE FOUNDATION REQUIREMENTS FOR YOUR PROJECT. Includes columns for DESCRIPTION, Ss REGION, and MAX DEAD LOAD.

Table for STEP 5: SELECT APPLICABLE SHEET INDEX FOR YOUR PROJECT. Includes columns for TOTAL ROOF DEAD LOAD, DEAD LOAD, and EXAMPLES.

SCOPE OF WORK NARRATIVE. THESE DRAWINGS ILLUSTRATE THE FABRICATION AND INSTALLATION REQUIREMENTS FOR A FREE-STANDING PREFABRICATED STEEL SHADE STRUCTURE...

NOTICE OF DISCLAIMER FOR STRUCTURAL ENGINEERING RESPONSIBILITY. 1. PER TITLE 24, PART 1, SECTION 4-316(e) OF THE CALIFORNIA CODE OF REGULATIONS, THIS NOTICE SHALL BE GIVEN TO DSA PRIOR TO THE APPROVAL OF PLANS AND SPECIFICATIONS...

CONSTRUCTION NOTES. 1. A DSA-CERTIFIED CLASS 3 PROJECT INSPECTOR IS REQUIRED FOR THIS PROJECT. 2. CHANGES TO THE APPROVED DRAWINGS AND SPECIFICATIONS SHALL BE MADE BY ADDENDA OR CONSTRUCTION CHANGE DOCUMENT (CCD) APPROVED BY DSA...

Table with columns: DESCRIPTION, DESIGN VALUES. Includes sections for WIND DESIGN, SEISMIC DESIGN, and FLOOD DESIGN.

Table with columns: STRENGTH Pz (28 DAYS), W/C RATIO (NON-AIR ENTRAINED), W/C RATIO (AIR ENTRAINED), SLUMP (in), UNIT WEIGHT (NORMAL WEIGHT).

Table for STEP 1: IDENTIFY PROJECT NAME AND SCHOOL DISTRICT.

Table for STEP 2: SELECT FRAME DIMENSIONS FOR YOUR PROJECT.

Table for STEP 3: IDENTIFY THE Ss ACCELERATION (g) FOR YOUR PROJECT.

Table for STEP 4: IDENTIFY THE FOUNDATION REQUIREMENTS FOR YOUR PROJECT.

Table for STEP 5: SELECT APPLICABLE SHEET INDEX FOR YOUR PROJECT.

Table with columns: DESCRIPTION, DESIGN VALUES. Includes WIND DESIGN and SEISMIC DESIGN.

Table with columns: DESCRIPTION, DESIGN VALUES. Includes WIND DESIGN and SEISMIC DESIGN.

PRE-CHECK (PC) DOCUMENT Code: 2019 CBC A separate project application for construction is required.

REVISED BY: [Blank]

GENERAL INFO

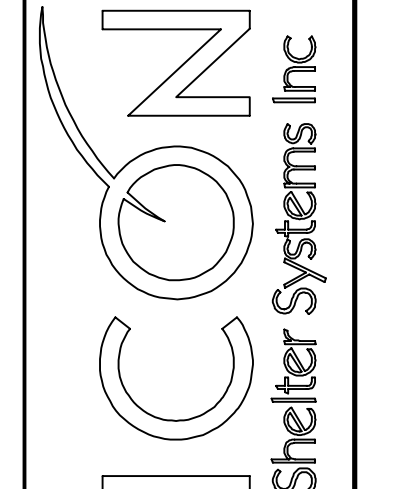

1455 LINCOLN AVE. HOLLAND MI, 49423 616.396.0919 800.748.0985 616.396.0944 FX

LS1.0

REVISED BY: [Blank]

PROJECT NO. 21-1504.01 DATE: 4/7/21 SHEET LS1.0

AD0.07

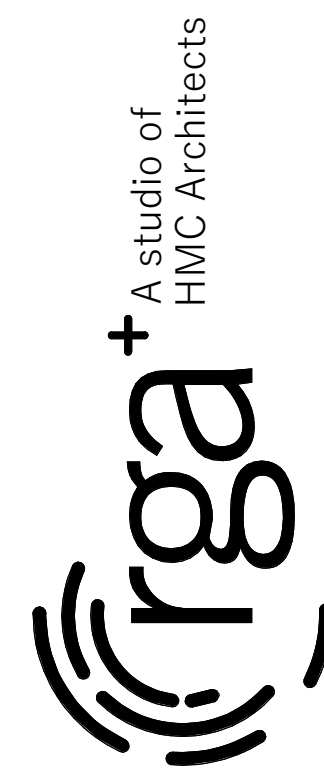

ICD STD: RH/DSA-PC
DRAWN BY: ANGEL
DATE: 4/2/2021
REV
REV DATE



APPROVED
DIV. OF THE STATE ARCHITECT
APP: 04-120013-PC
REVIEWED FOR
SS CS ACS
DATE: 08/06/2021

DSA 103

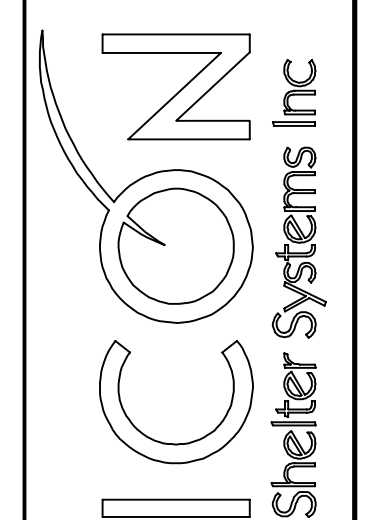

1455 LINCOLN AVE
HOLLAND MI, 49423
616.396.0919
800.748.0985
616.396.0944 FX

LS1.1

PRE-CHECK (PC) DOCUMENT
Code: 2019 CBC
A separate project application for construction is required.

PRINTED ON:

SHADE STRUCTURE AT ALICE BIRNEY
PUBLIC WALDORF K-8 SCHOOL
SACRAMENTO CITY UNIFIED SCHOOL DISTRICT
SACRAMENTO, CA

Revision

Copyright © 2021 Rainforth Grau Architects. All rights reserved. Reproduction of these plans, either in whole or in part, including any form of copying and/or preparation of derivative works thereof, for any reason without prior written permission, is strictly prohibited.

DSA 103

PROJECT NO. 21-1504.01
DATE: 4/7/22
SHEET

LS1.1

AD0.08

FOR ALL TESTING AND INSPECTION ITEMS SEE THE DSA APPROVED 103 FOR THIS PROJECT.

DSA 103-19: LISTING OF STRUCTURAL TESTS & SPECIAL INSPECTIONS (SOILS), 2019 CBC
Application Number: 04-00000 School Name: ICON Shelter Systems School District: PC Submittal
DSA File Number: 2021-07-14 05:50:33 Date Created: 2021-07-14 05:50:33

Table with 4 columns: Test or Special Inspection, Type, Performed By, Code References and Notes. Includes sections for 5. RETAINING WALLS and 6. OTHER SOIL.

DSG DSA 103-19 (Revised 07/16/2020)
DIVISION OF THE STATE ARCHITECT DEPARTMENT OF GENERAL SERVICES STATE OF CALIFORNIA
Page 4 of 11

DSA 103-19: LISTING OF STRUCTURAL TESTS & SPECIAL INSPECTIONS (SOILS), 2019 CBC
Application Number: 04-00000 School Name: ICON Shelter Systems School District: PC Submittal
DSA File Number: 2021-07-14 05:50:33 Date Created: 2021-07-14 05:50:33

Table with 4 columns: Test or Special Inspection, Type, Performed By, Code References and Notes. Includes sections for 4. CAST-IN-PLACE DEEP FOUNDATIONS (PIERS) and 4. CONCRETE PIERS.

DSG DSA 103-19 (Revised 07/16/2020)
DIVISION OF THE STATE ARCHITECT DEPARTMENT OF GENERAL SERVICES STATE OF CALIFORNIA
Page 3 of 11

DSA 103-19: LISTING OF STRUCTURAL TESTS & SPECIAL INSPECTIONS (SOILS), 2019 CBC
Application Number: 04-00000 School Name: ICON Shelter Systems School District: PC Submittal
DSA File Number: 2021-07-14 05:50:33 Date Created: 2021-07-14 05:50:33

Geotechnical Reports: Project has a geotechnical report, or CDs indicate soils special inspection is required by GE

Table with 4 columns: Test or Special Inspection, Type, Performed By, Code References and Notes. Includes sections for 1. GENERAL and 2. SOIL COMPACTION AND FILL.

DSG DSA 103-19 (Revised 07/16/2020)
DIVISION OF THE STATE ARCHITECT DEPARTMENT OF GENERAL SERVICES STATE OF CALIFORNIA
Page 2 of 11

DSA 103-19: LISTING OF STRUCTURAL TESTS & SPECIAL INSPECTIONS, 2019 CBC
Application Number: 04-00000 School Name: ICON Shelter Systems School District: PC Submittal
DSA File Number: 2021-07-14 05:50:33 Date Created: 2021-07-14 05:50:33

IMPORTANT: This form is only a summary list of structural tests and some of the special inspections required for the project. Generally, the structural tests and special inspections noted on this form are those that will be performed by the Geotechnical Engineer of Record, Laboratory of Record, or Special Inspector.

Table with 2 columns: KEY TO COLUMNS and PERFORMED BY. Defines terms like Continuous, Periodic, and Test.

DSG DSA 103-19 (Revised 07/16/2020)
DIVISION OF THE STATE ARCHITECT DEPARTMENT OF GENERAL SERVICES STATE OF CALIFORNIA
Page 1 of 11

DSA 103-19: LISTING OF STRUCTURAL TESTS & SPECIAL INSPECTIONS (Concrete), 2019 CBC
Application Number: 04-00000 School Name: ICON Shelter Systems School District: PC Submittal
DSA File Number: 2021-07-14 05:50:33 Date Created: 2021-07-14 05:50:33

Table with 4 columns: Test or Special Inspection, Type, Performed By, Code References and Notes. Includes sections for 19.3 SHOP WELDING and 23. ANCHOR BOLTS AND ANCHOR RODS.

DSG DSA 103-19 (Revised 07/16/2020)
DIVISION OF THE STATE ARCHITECT DEPARTMENT OF GENERAL SERVICES STATE OF CALIFORNIA
Page 8 of 11

DSA 103-19: LISTING OF STRUCTURAL TESTS & SPECIAL INSPECTIONS (Concrete), 2019 CBC
Application Number: 04-00000 School Name: ICON Shelter Systems School District: PC Submittal
DSA File Number: 2021-07-14 05:50:33 Date Created: 2021-07-14 05:50:33

Table with 4 columns: Test or Special Inspection, Type, Performed By, Code References and Notes. Includes sections for 17. STRUCTURAL STEEL JOINTS AND WELDS and 18. WELDS.

DSG DSA 103-19 (Revised 07/16/2020)
DIVISION OF THE STATE ARCHITECT DEPARTMENT OF GENERAL SERVICES STATE OF CALIFORNIA
Page 7 of 11

DSA 103-19: LISTING OF STRUCTURAL TESTS & SPECIAL INSPECTIONS (Concrete), 2019 CBC
Application Number: 04-00000 School Name: ICON Shelter Systems School District: PC Submittal
DSA File Number: 2021-07-14 05:50:33 Date Created: 2021-07-14 05:50:33

Table with 4 columns: Test or Special Inspection, Type, Performed By, Code References and Notes. Includes sections for 17. STRUCTURAL STEEL JOINTS AND WELDS and 18. WELDS.

DSG DSA 103-19 (Revised 07/16/2020)
DIVISION OF THE STATE ARCHITECT DEPARTMENT OF GENERAL SERVICES STATE OF CALIFORNIA
Page 6 of 11

DSA 103-19: LISTING OF STRUCTURAL TESTS & SPECIAL INSPECTIONS (Concrete), 2019 CBC
Application Number: 04-00000 School Name: ICON Shelter Systems School District: PC Submittal
DSA File Number: 2021-07-14 05:50:33 Date Created: 2021-07-14 05:50:33

Table with 4 columns: Test or Special Inspection, Type, Performed By, Code References and Notes. Includes sections for 7. CAST-IN-PLACE CONCRETE and 8. HIGH-STRENGTH BOLTS, WASHERS, AND WASHERS.

DSG DSA 103-19 (Revised 07/16/2020)
DIVISION OF THE STATE ARCHITECT DEPARTMENT OF GENERAL SERVICES STATE OF CALIFORNIA
Page 5 of 11

DSA 103-19: LIST OF REQUIRED VERIFIED REPORTS, CBC 2019
Application Number: 04-00000 School Name: ICON Shelter Systems School District: PC Submittal
DSA File Number: 2021-07-14 05:50:33 Date Created: 2021-07-14 05:50:33

- 1. Soils Testing and Inspection: Geotechnical Verified Report Form DSA 293
2. Structural Testing and Inspection: Laboratory Verified Report Form DSA 291
3. Shop Welding Inspection: Laboratory Verified Report Form DSA 291, or, for independently contracting SI, Special Inspection Verified Report Form DSA 292
4. High-Strength Bolt Installation Inspection: Laboratory Verified Report Form DSA 291, or, for independently contracting SI, Special Inspection Verified Report Form DSA 292

DSG DSA 103-19 (Revised 07/16/2020)
DIVISION OF THE STATE ARCHITECT DEPARTMENT OF GENERAL SERVICES STATE OF CALIFORNIA
Page 11 of 11

DSA 103-19: LISTING OF STRUCTURAL TESTS & SPECIAL INSPECTIONS (SIGNATURE), 2019 CBC
Application Number: 04-00000 School Name: ICON Shelter Systems School District: PC Submittal
DSA File Number: 2021-07-14 05:50:33 Date Created: 2021-07-14 05:50:33

Name of Architect or Engineer in general contract language:
Name of Structural Engineer Other structural design has been prepared:
Signature of Architect or Structural Engineer:
Note: To facilitate DSA electronic mark-ups and identification stamp application, DSA Permittances against using secured electronic or digital signatures.

DSG DSA 103-19 (Revised 07/16/2020)
DIVISION OF THE STATE ARCHITECT DEPARTMENT OF GENERAL SERVICES STATE OF CALIFORNIA
Page 10 of 11

DSA 103-19: LISTING OF STRUCTURAL TESTS & SPECIAL INSPECTIONS (Steel and Aluminum), 2019 CBC
Application Number: 04-00000 School Name: ICON Shelter Systems School District: PC Submittal
DSA File Number: 2021-07-14 05:50:33 Date Created: 2021-07-14 05:50:33

Table with 4 columns: Test or Special Inspection, Type, Performed By, Code References and Notes. Includes section for 23. ANCHOR BOLTS AND ANCHOR RODS.

DSG DSA 103-19 (Revised 07/16/2020)
DIVISION OF THE STATE ARCHITECT DEPARTMENT OF GENERAL SERVICES STATE OF CALIFORNIA
Page 9 of 11

DSA STAMP

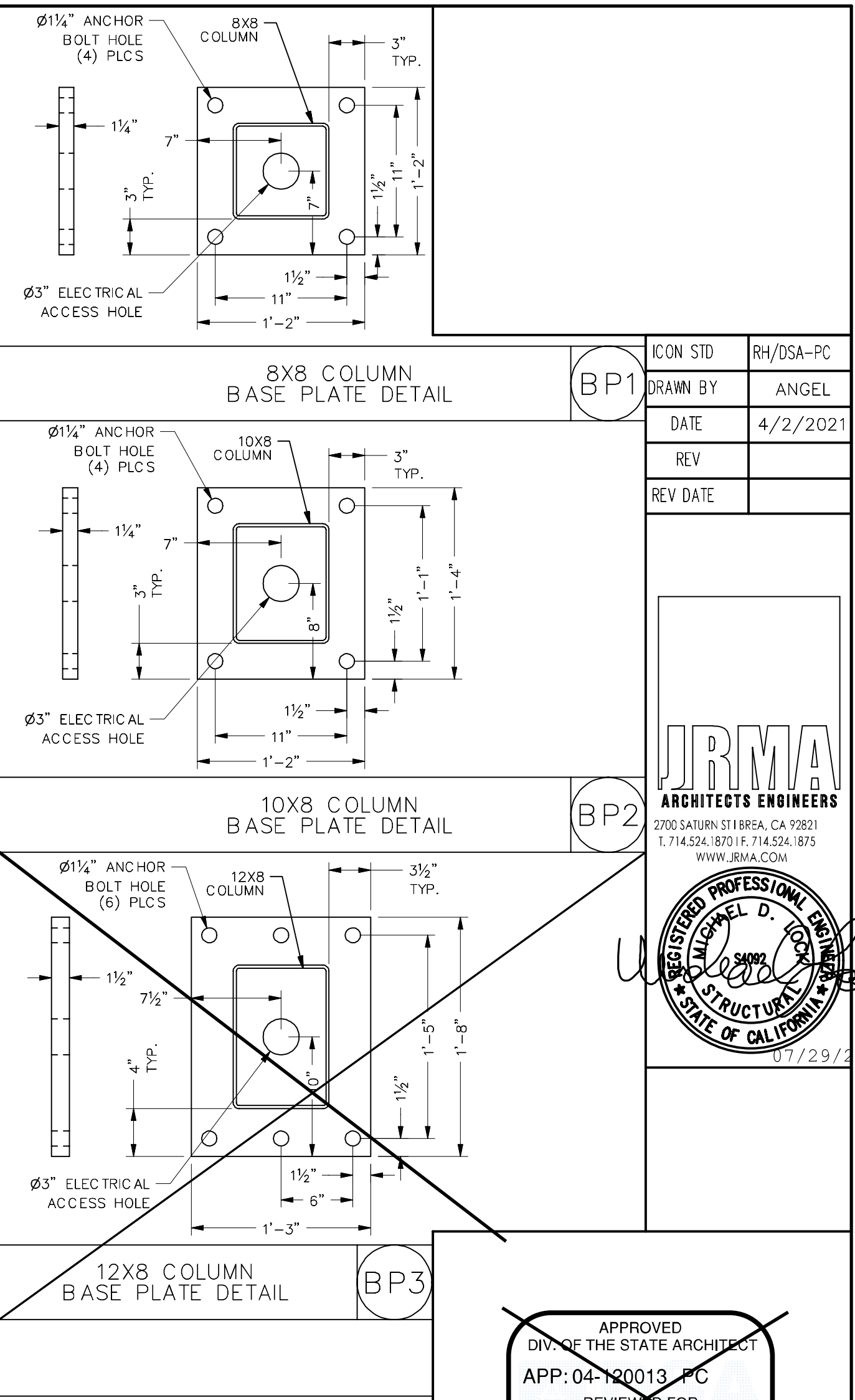
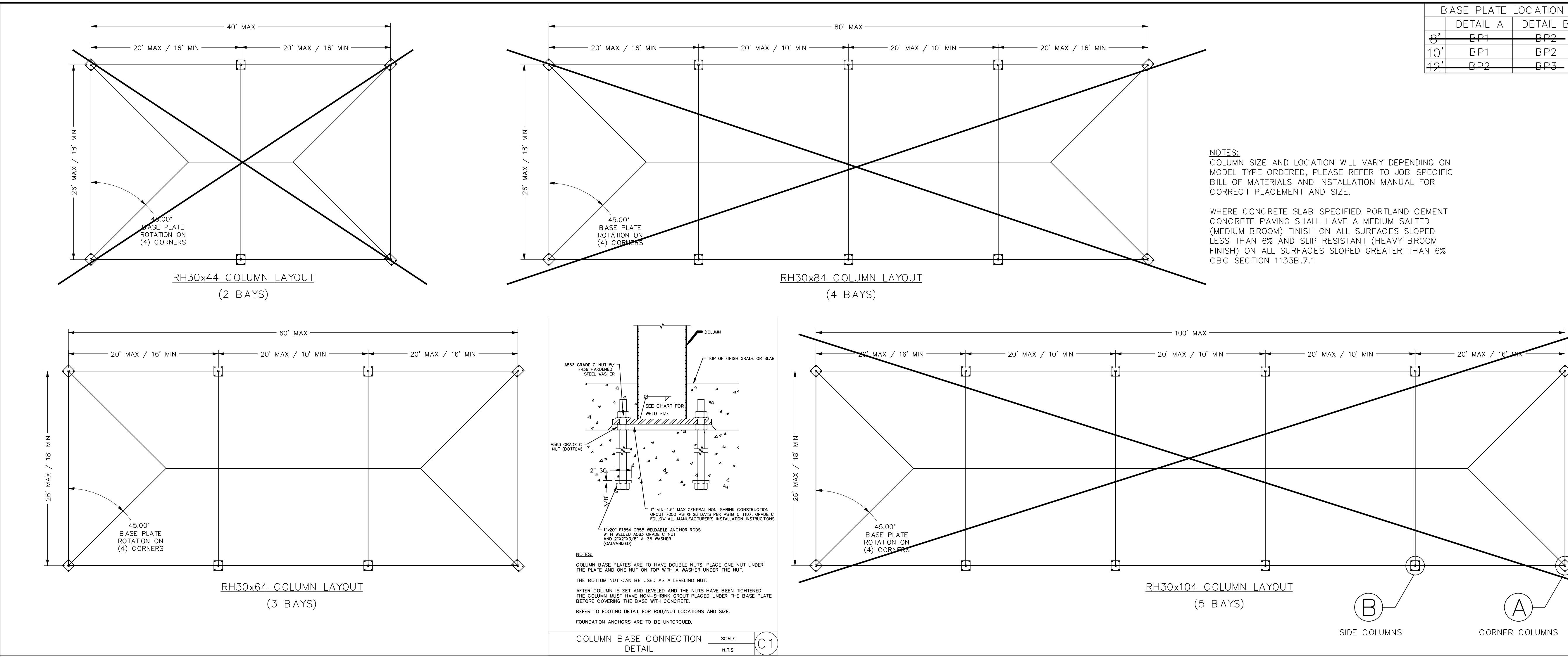

RH30 - PIER

8' height - Corner Columns				8' height - Side Columns				10' height - Corner Columns				10' height - Side Columns							
Soil Class	Depth (in)	Rebar Qty	Rebar Size	Soil Class	Depth (in)	Rebar Qty	Rebar Size	Soil Class	Depth (in)	Rebar Qty	Rebar Size	Soil Class	Depth (in)	Rebar Qty	Rebar Size				
Soil Class 3 - 1500 psf Bearing	24	114	6	6	Soil Class 4 - 2000 psf Bearing	24	98	6	6	Soil Class 3 - 3000 psf Bearing	24	88	6	6	Soil Class 3 - 3000 psf Bearing	30	118	6	6
Soil Class 5 - 1500 psf Bearing	36	144	12	6	Soil Class 4 - 2000 psf Bearing	30	132	6	6	Soil Class 3 - 3000 psf Bearing	30	118	6	6	Soil Class 3 - 3000 psf Bearing	30	118	6	6
Soil Class 5 - 1500 psf Bearing	36	136	12	6	Soil Class 4 - 2000 psf Bearing	30	124	8	6	Soil Class 3 - 3000 psf Bearing	30	112	8	6	Soil Class 3 - 3000 psf Bearing	30	112	8	6
Soil Class 5 - 1500 psf Bearing	36	132	8	6	Soil Class 4 - 2000 psf Bearing	30	112	8	6	Soil Class 3 - 3000 psf Bearing	30	102	8	6	Soil Class 3 - 3000 psf Bearing	30	102	8	6
Soil Class 5 - 1500 psf Bearing	36	140	12	6	Soil Class 4 - 2000 psf Bearing	36	120	12	6	Soil Class 3 - 3000 psf Bearing	36	108	12	6	Soil Class 3 - 3000 psf Bearing	36	108	12	6

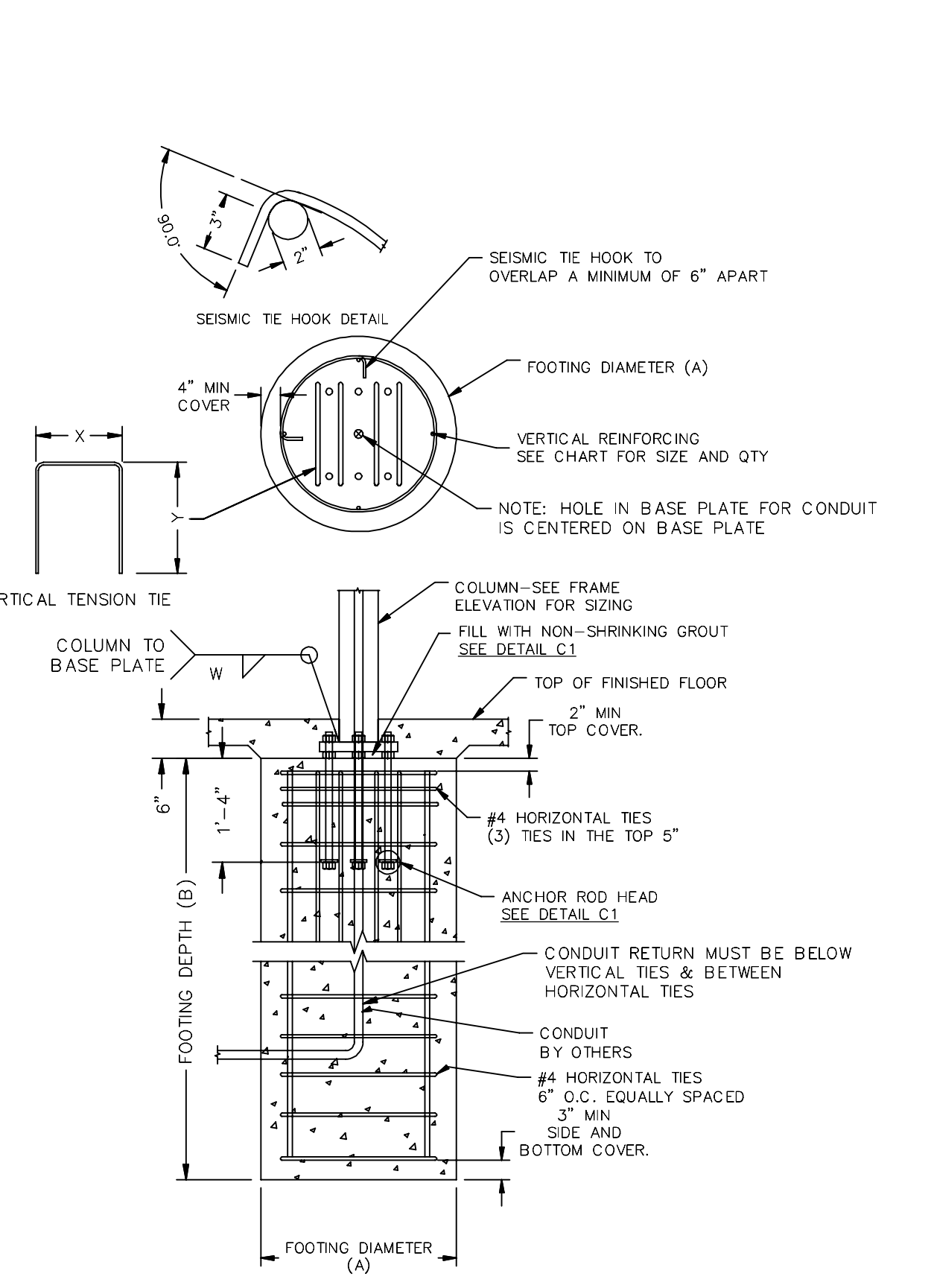

SEE DETAILS BP1, BP2 OR BP3 FOR ANCHOR BOLT PATTERNS
BP1 & BP2 ARE (4) BOLT PATTERN WHILE BP3 IS A (6) BOLT

RH30 - SPREAD

8' height - Corner Columns				8' height - Side Columns				10' height - Corner Columns				10' height - Side Columns							
Soil Class	Depth (in)	Rebar Qty	Rebar Size	Soil Class	Depth (in)	Rebar Qty	Rebar Size	Soil Class	Depth (in)	Rebar Qty	Rebar Size	Soil Class	Depth (in)	Rebar Qty	Rebar Size				
Soil Class 5 - 1500 psf Bearing	60	30	4	6	Soil Class 4 - 2000 psf Bearing	56	30	4	6	Soil Class 3 - 3000 psf Bearing	54	30	4	6	Soil Class 3 - 3000 psf Bearing	54	30	4	6
Soil Class 5 - 1500 psf Bearing	80	30	5	6	Soil Class 4 - 2000 psf Bearing	72	30	5	6	Soil Class 3 - 3000 psf Bearing	68	30	5	6	Soil Class 3 - 3000 psf Bearing	68	30	5	6
Soil Class 5 - 1500 psf Bearing	66	30	5	6	Soil Class 4 - 2000 psf Bearing	60	30	4	6	Soil Class 3 - 3000 psf Bearing	57	30	4	6	Soil Class 3 - 3000 psf Bearing	57	30	4	6
Soil Class 5 - 1500 psf Bearing	81	30	5	6	Soil Class 4 - 2000 psf Bearing	72	30	5	6	Soil Class 3 - 3000 psf Bearing	69	30	5	6	Soil Class 3 - 3000 psf Bearing	69	30	5	6
Soil Class 5 - 1500 psf Bearing	78	30	5	6	Soil Class 4 - 2000 psf Bearing	72	30	5	6	Soil Class 3 - 3000 psf Bearing	72	30	5	6	Soil Class 3 - 3000 psf Bearing	72	30	5	6
Soil Class 5 - 1500 psf Bearing	64	30	6	6	Soil Class 4 - 2000 psf Bearing	75	30	5	6	Soil Class 3 - 3000 psf Bearing	75	30	5	6	Soil Class 3 - 3000 psf Bearing	75	30	5	6

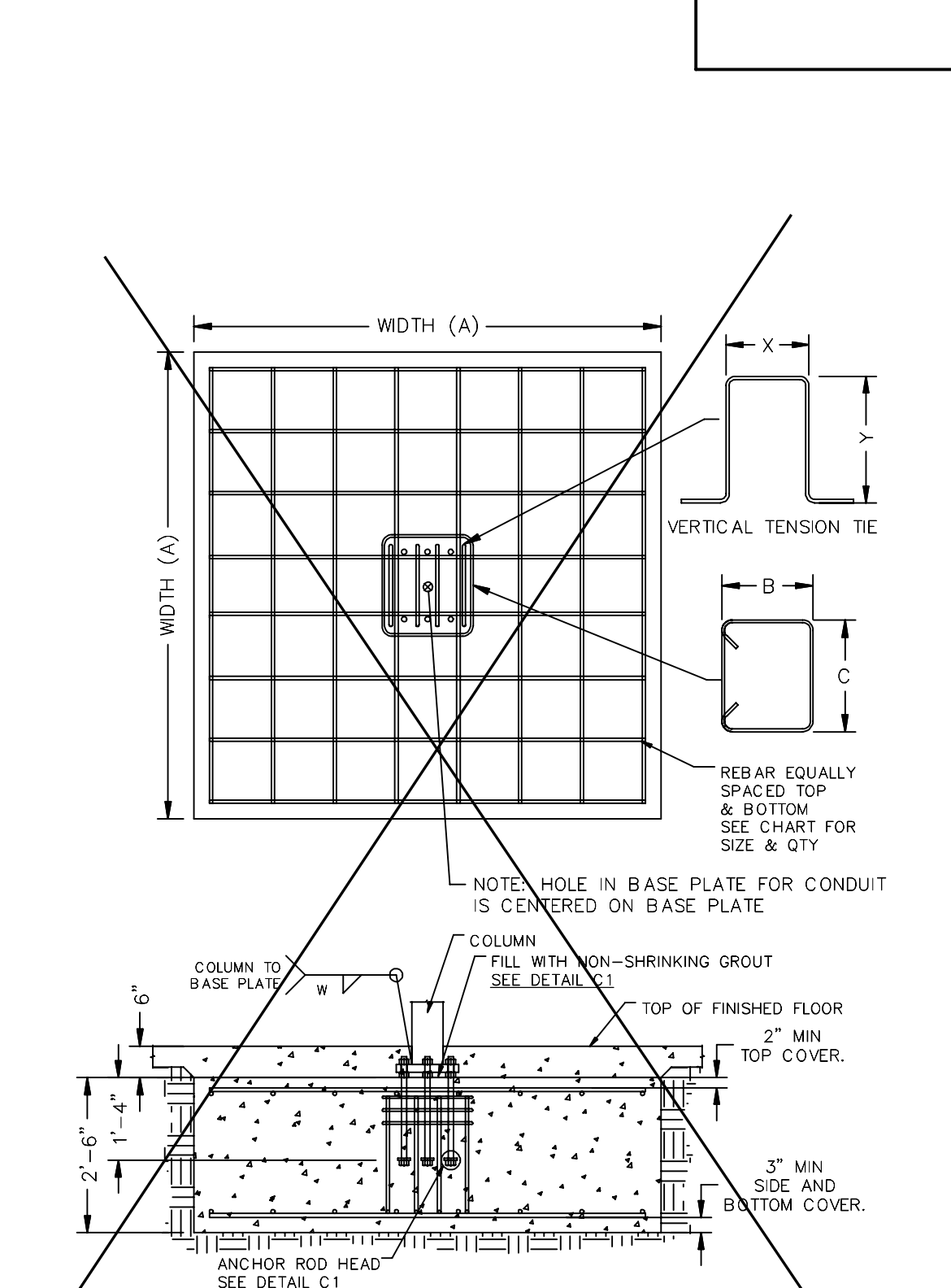

SEE DETAILS BP1, BP2 OR BP3 FOR ANCHOR BOLT PATTERNS
BP1 & BP2 ARE (4) BOLT PATTERN WHILE BP3 IS A (6) BOLT

PRE-CHECK (PC) DOCUMENT
Code: 2019 CBC
A separate project application for construction is required.

LS3.0

PRINTED ON:

SHADE STRUCTURE AT ALICE BIRNEY
PUBLIC WALDORF K-8 SCHOOL
SACRAMENTO CITY UNIFIED SCHOOL DISTRICT
SACRAMENTO, CA

Revision

30' WIDE RECTANGULAR HIP FOUNDATION PLAN

Copyright © 2021 Rainforth Grau Architects. All rights reserved. Reproduction of these plans, either in whole or in part, including any form of copying and/or preparation of derivative works thereof, for any reason without prior written permission, is strictly prohibited.

1455 LINCOLN AVE
HOLLAND MI, 49423
616.396.0919
800.748.0985
616.396.0944 FX

PROJECT NO. 21-1504.01
DATE: 4/7/22
SHEET

LS3.0
AD0.09

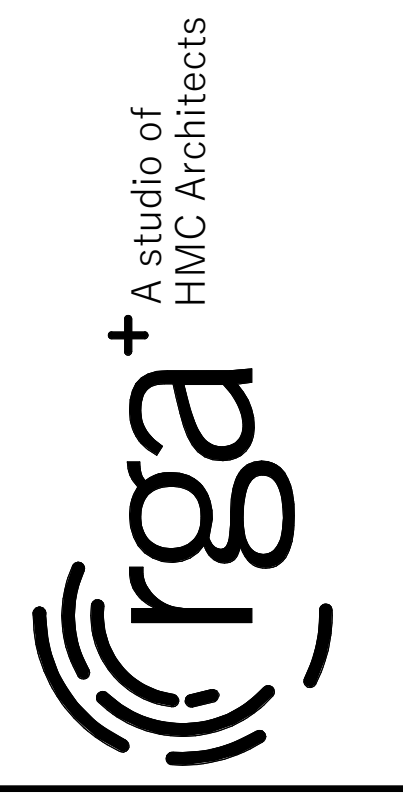

ICON STD	RH/USA-PC
DRAWN BY	ANGEL
DATE	4/2/2021
REV	
REV DATE	

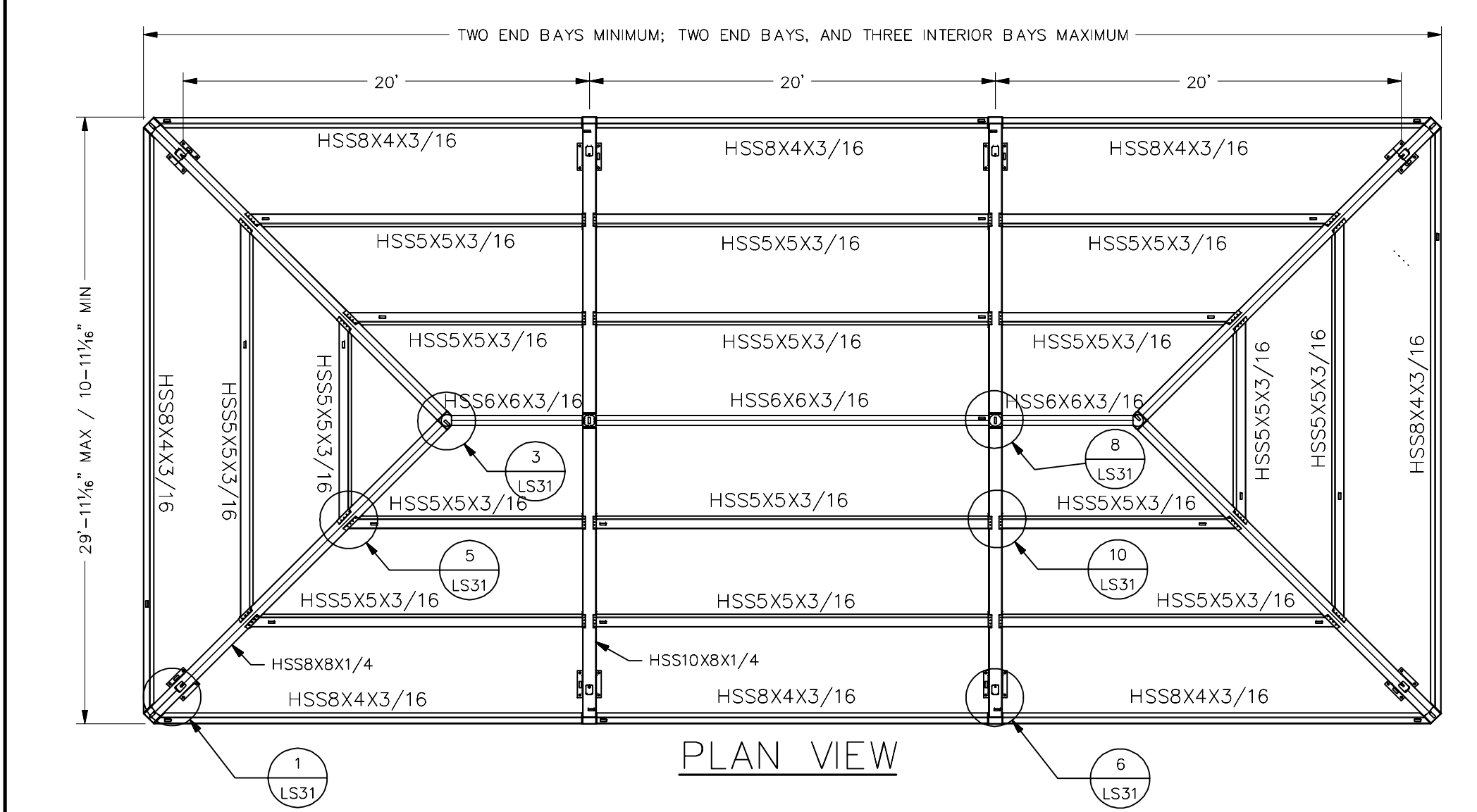
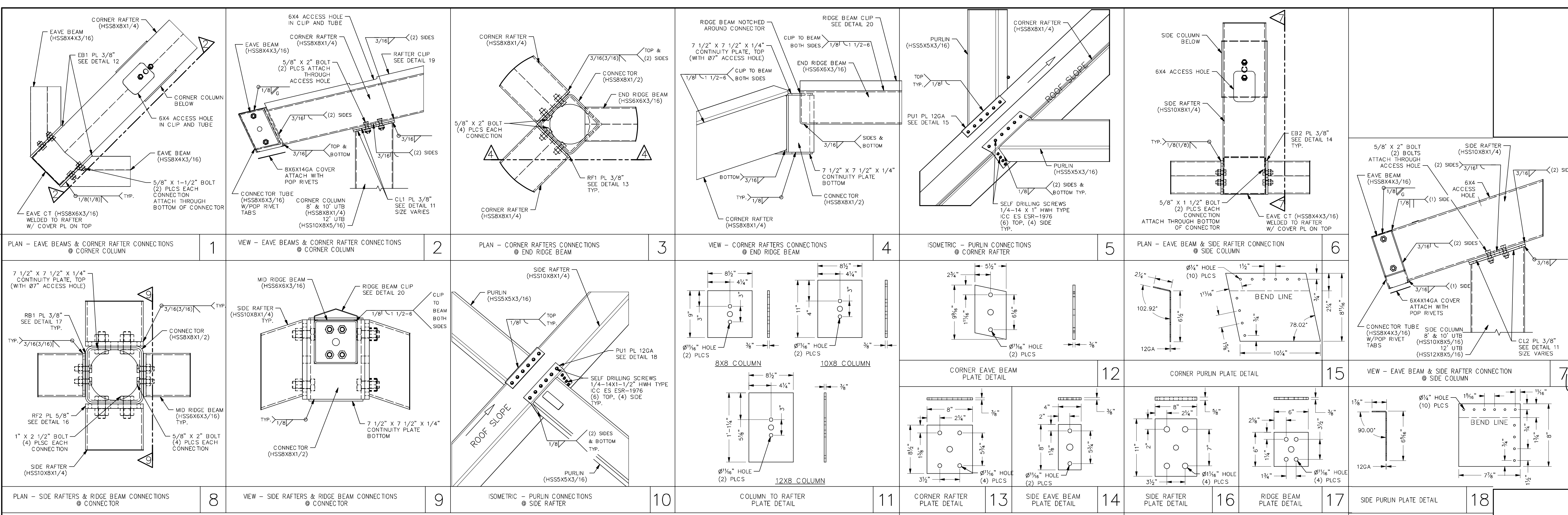

**NOTE:
QUANTITIES WILL VARY DEPENDING ON SHELTER SIZE ORDERED, PLEASE
REFER TO JOB SPECIFIC BILL OF MATERIALS AND INSTALLATION MANUAL.

ITEM	QTY	PART NUMBER	DESCRIPTION	MATERIAL	LENGTH	UNIT WEIGHT
1	4		CORNER COLUMN	**SEE NOTE BELOW		353 lbmass
2	*		SIDE COLUMN	**SEE NOTE BELOW		399 lbmass
3	2		LH SIDE EAVE BEAM	HSS8X4X3/16		311 lbmass
4	2		RH SIDE EAVE BEAM	HSS8X4X3/16		311 lbmass
5	2		END EAVE BEAM	HSS8X4X3/16		422 lbmass
6	*		SIDE EAVE BEAM	HSS8X4X3/16		287 lbmass
7	4		CORNER RAFTER	HSS8X8X1/4		607 lbmass
8	*		SIDE RAFTER	HSS10X8X1/4		474 lbmass
9	2		END RIDGE BEAM	HSS8X6X3/16		149 lbmass
10	*		MID RIDGE BEAM	HSS8X6X3/16		328 lbmass
11	*		CONNECTOR	HSS8X8X1/2		48 lbmass
12	2		LH SIDE PURLIN 1	HSS5X5X3/16		238 lbmass
13	2		RH SIDE PURLIN 1	HSS5X5X3/16		238 lbmass
14	2		END PURLIN 1	HSS5X5X3/16		278 lbmass
15	2		LH SIDE PURLIN 2	HSS5X5X3/16		167 lbmass
16	2		RH SIDE PURLIN 2	HSS5X5X3/16		167 lbmass
17	2		END PURLIN 2	HSS5X5X3/16		137 lbmass
18	*		MID PURLIN	HSS5X5X3/16		284 lbmass

**NOTE:
MATERIAL WILL VARY DEPENDING ON SHELTER SIZE ORDERED.

- CORNER COLUMN 8' UTB - (HSS8X8X1/4)
- SIDE COLUMN 8' UTB - (HSS10X8X5/16)
- CORNER COLUMN 10' UTB - (HSS8X8X1/4)
- SIDE COLUMN 10' UTB - (HSS10X8X5/16)
- CORNER COLUMN 12' UTB - (HSS10X8X5/16)
- SIDE COLUMN 12' UTB - (HSS12X8X5/16)

MODEL DESIGNATION	
RH30X44	2 BAY
RH30X64	3 BAY
RH30X84	4 BAY
RH30X104	5 BAY

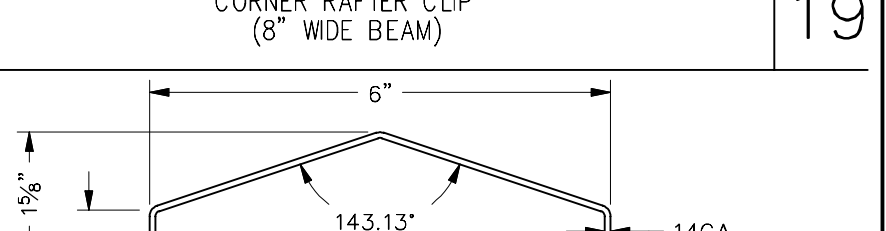
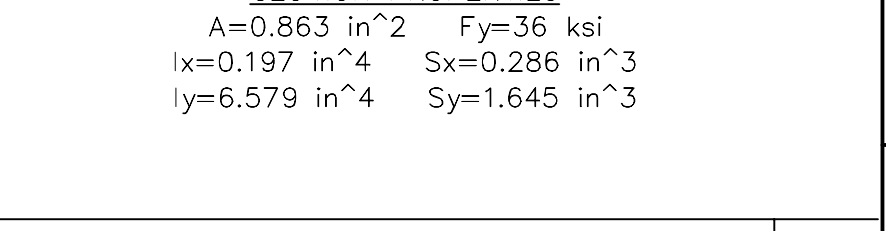
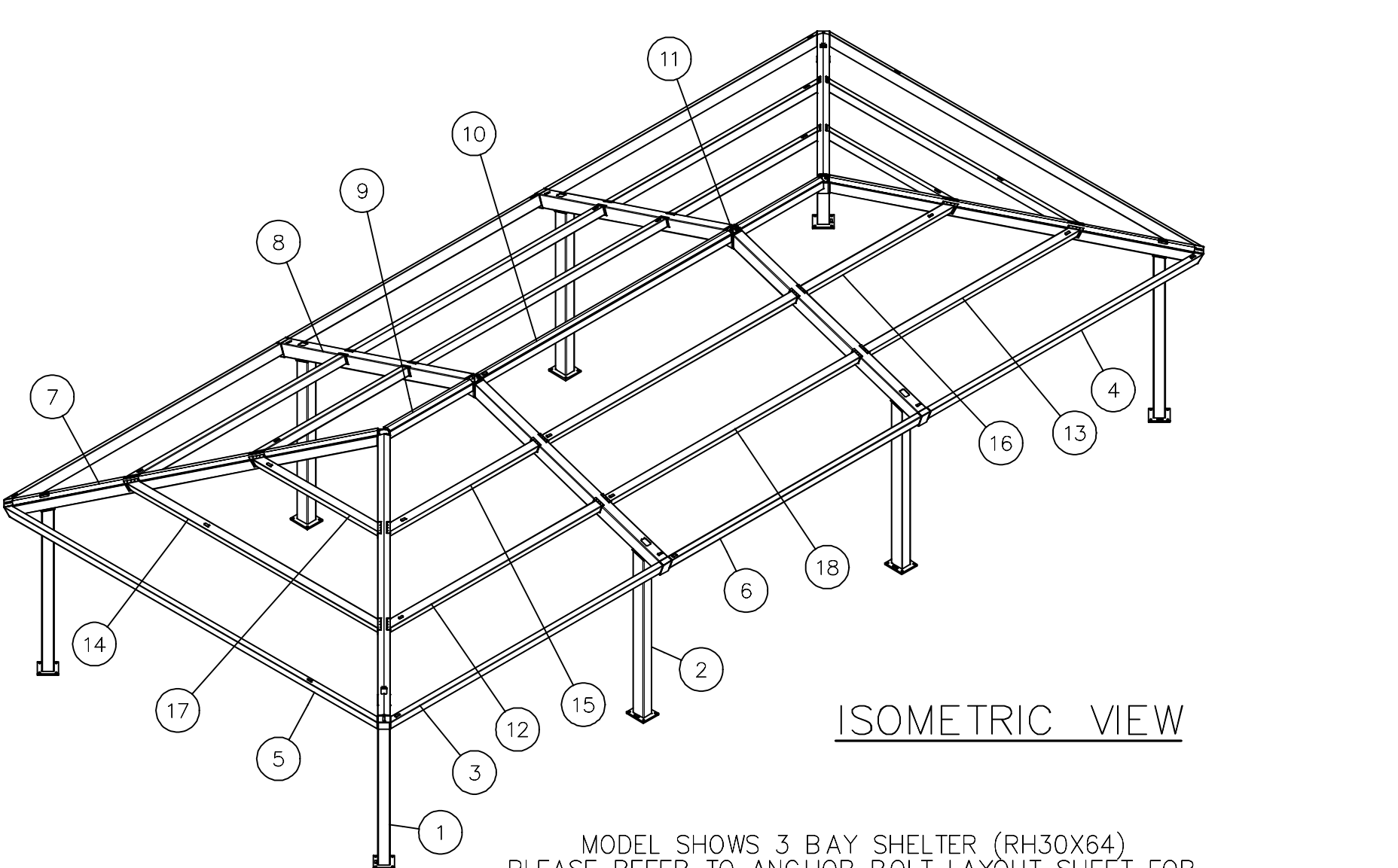
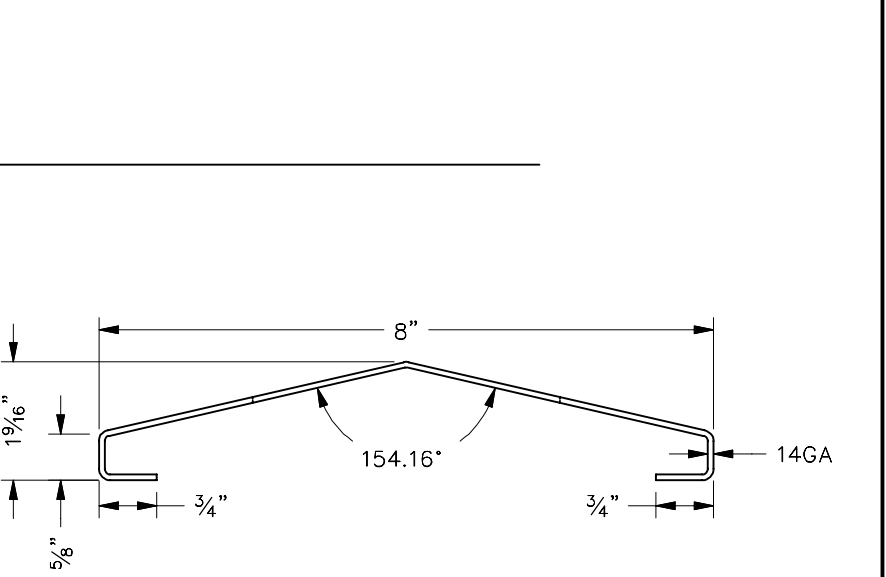
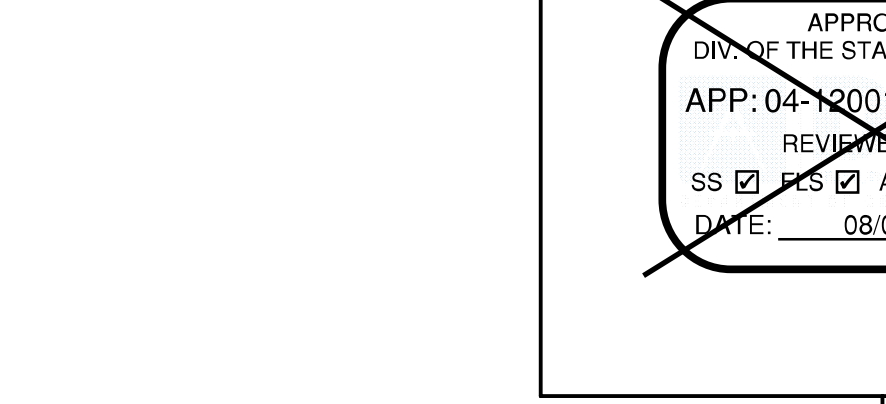
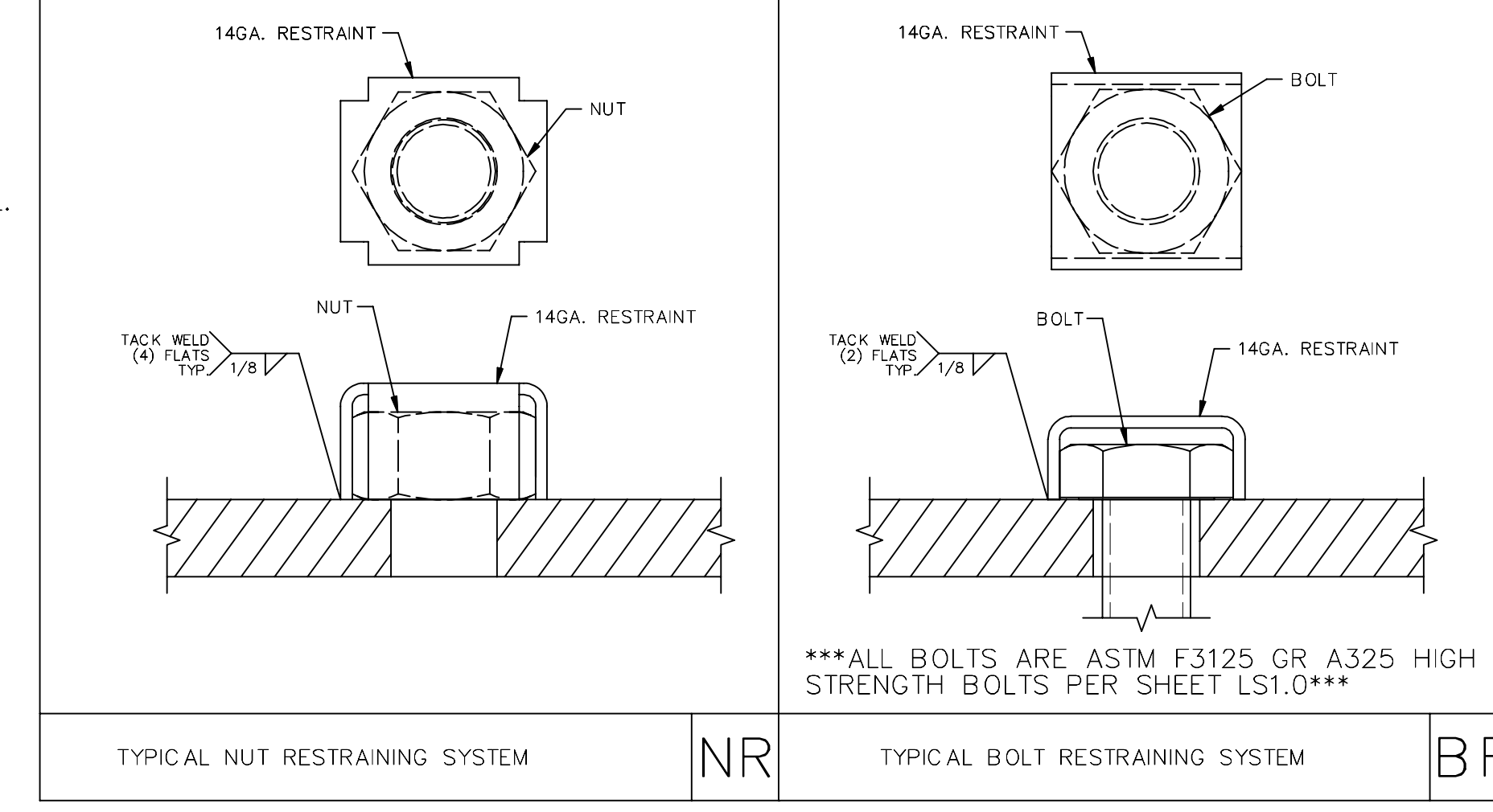
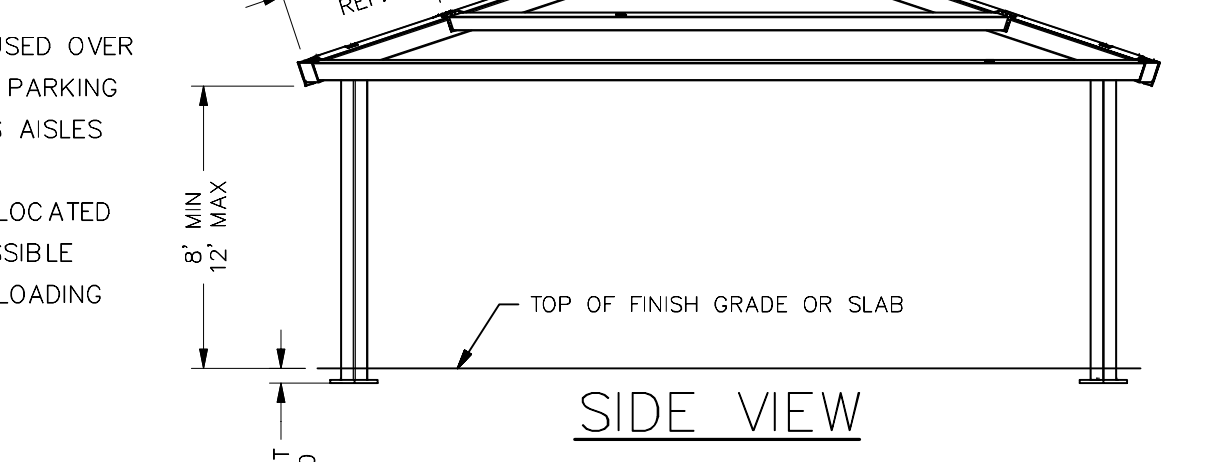
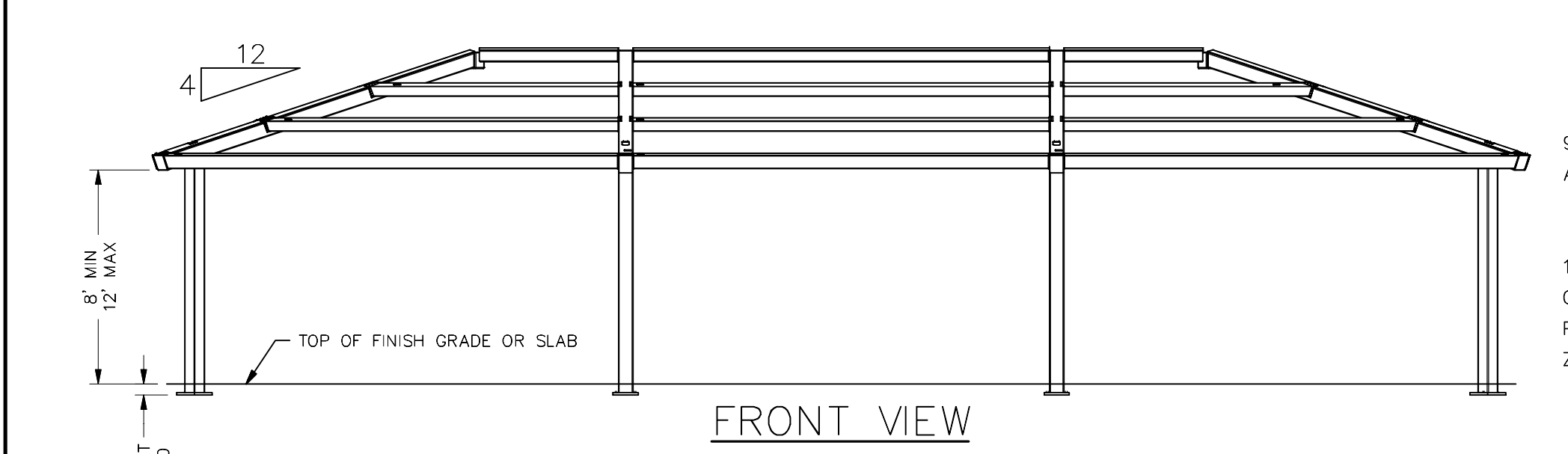

30' WIDE
RECTANGULAR HIP
FRAMING &
CONNECTION DETAILS

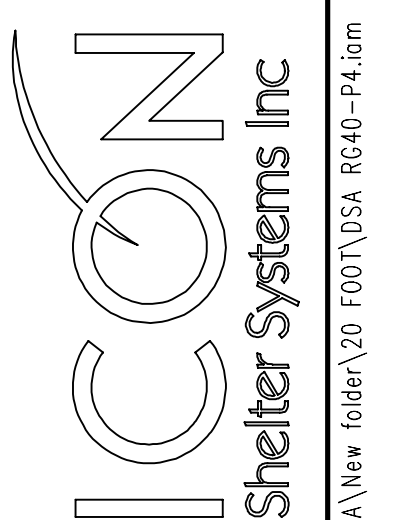

1455 LINCOLN AVE
HOLLAND MI, 49423
616.396.0919
800.748.0985
616.396.0944 FX

PRE-CHECK (PC) DOCUMENT
Code: 2019 CBC
A separate project application for construction is required.

LS3.1

SHADE STRUCTURE AT ALICE BIRNEY
PUBLIC WALDORF K-8 SCHOOL
SACRAMENTO CITY UNIFIED SCHOOL DISTRICT
SACRAMENTO, CA

Revision

Copyright © 2021 Rainforest Grau Architects. All rights reserved.
Reproduction of these plans, either in whole or in part, including
any form of copying and/or preparation of derivative works thereof,
for any reason without prior written permission, is strictly prohibited.

30' WIDE
RECTANGULAR HIP
FRAMING &
CONNECTION DETAILS

PROJECT NO.	21-1504.01
DATE	4/7/22
SHEET	LS3.1

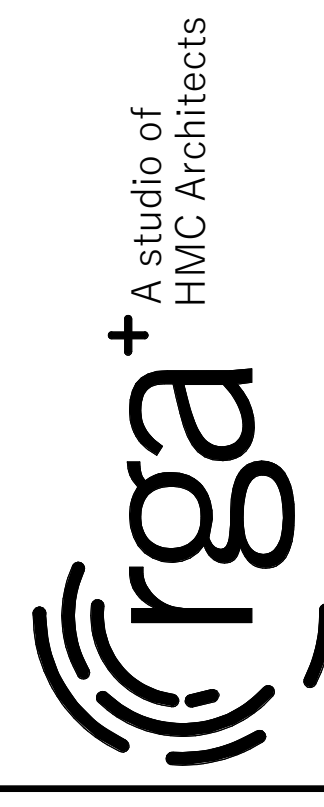

07/29/2021

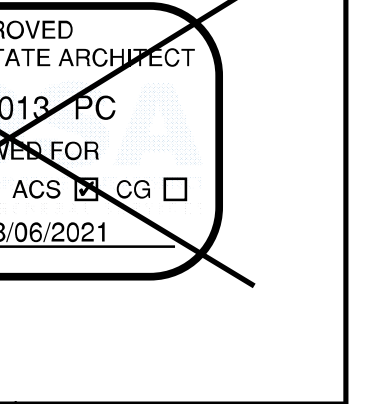

SHADE STRUCTURE AT ALICE BIRNEY
PUBLIC WALDORF K-8 SCHOOL
SACRAMENTO CITY UNIFIED SCHOOL DISTRICT
SACRAMENTO, CA

Revision

30' WIDE RECTANGULAR HIP STANDING SEAM ROOFING PLAN

LS3.4

PRE-CHECK (PC) DOCUMENT
Code: 2019 CBC
A separate project application for construction is required.

PRINTED ON:

PROJECT NO. 21-1504.01
DATE: 4/7/22
SHEET

LS3.4
AD0.11

TRIM REFERENCE

ORDER OF INSTALLATION

FIELD CUTTING ROOF PANELS S-CP1

INSTALLATION OF FIRST ROOF PANEL S-P11

INSTALLATION OF SECOND ROOF PANEL S-P12

INSTALLATION OF HIP C-CLOSURE S-HC1

INSTALLATION OF C-CLOSURE @ RIDGE S-RC1

INSTALLATION OF CORNER TRIM S-C11

INSTALLATION OF HIP CAP S-HT1

INSTALLATION OF RIDGE CAP S-RT1

OPTIONAL GUTTER INSTALLATION STANDING SEAM ROOF GU1

OPTIONAL GUTTER SECTION STANDING SEAM ROOF GU2

ROOF NOTES

ATTENTION INSTALLERS: METAL SHAVINGS LEFT ON ROOF WILL QUICKLY RUST AND STAIN THE ROOF FINISH!

DRILLING OR INSTALLING ROOF FASTENERS WILL CAUSE METAL SHAVINGS. THESE SHAVINGS MUST BE CAREFULLY REMOVED AT THE END OF EACH DAY BY EITHER SWEEPING OR BRUSHING THE INSTALLED ROOF.

INSTALLED CORRECTLY	INSTALLED TOO TIGHT	INSTALLED TOO LOOSE
THE SEALING MATERIAL SLIGHTLY VISIBLE AROUND THE EDGE OF THE METAL WASHER	THE SEALING MATERIAL IS DEFORMED BEYOND THE EDGE OF THE METAL WASHER	THE SEALING MATERIAL IS NOT VISIBLE AROUND THE EDGE OF THE METAL WASHER

THE DETAILS SHOWN ARE SUGGESTIONS OR GUIDELINES ON HOW TO ERECT THE METAL ROOFING SYSTEM. THE INFORMATION SHOWN IS ACCURATE, BUT IT IS NOT INTENDED TO COVER ALL INSTANCES, BUILDING REQUIREMENTS, DESIGNS OR CODES. CHANGES TO THE DETAILS MAY BE REQUIRED DUE TO FIELD CONDITIONS.

THE ERECTOR SHOULD THOROUGHLY FAMILIARIZE THEMSELVES WITH ALL INSTALLATION INSTRUCTION MATERIAL BEFORE STARTING WORK.

THE PANELS SHOULD BE INSTALLED PLUMB, STRAIGHT, AND ACCURATELY TO THE ADJACENT WORK.

ERECTORS SHALL BE RESPONSIBLE TO ENSURE THAT THE DETAILS MEET PARTICULAR BUILDING REQUIREMENTS AND TO ASSURE ADEQUATE WATER TIGHTNESS.

FOR THE BEST APPEARANCE ALL TRIM AND FLASHING SHALL BE INSTALLED TRUE, AND IN PROPER ALIGNMENT, WITH ALL EXPOSED FASTENERS EQUALLY SPACED.

SOME FIELD CUTTING AND/OR FITTING OF PANELS, TRIM AND FLASHING IS TO BE EXPECTED BY THE ERECTOR. MINOR FIELD CORRECTIONS ARE PART OF NORMAL ERECTION WORK.

THE INSTALLATION SHALL BE PERFORMED BY EXPERIENCED METAL CRAFTSMEN AND WORKSMANSHIP SHALL MEET THE BEST INDUSTRY STANDARDS.

30' WIDE RECTANGULAR HIP STANDING SEAM ROOFING

NOTE: DETAILS TYPICAL FOR ALL LAYOUTS

RH30X44S (2 BAYS)

RH30X84S (4 BAYS)

RH30X104S (5 BAYS)

RH30X64S (3 BAYS)

RH30X44S (2 BAYS)

END LAYOUT

ROOF PLAN VIEW

ROOF SECTION A

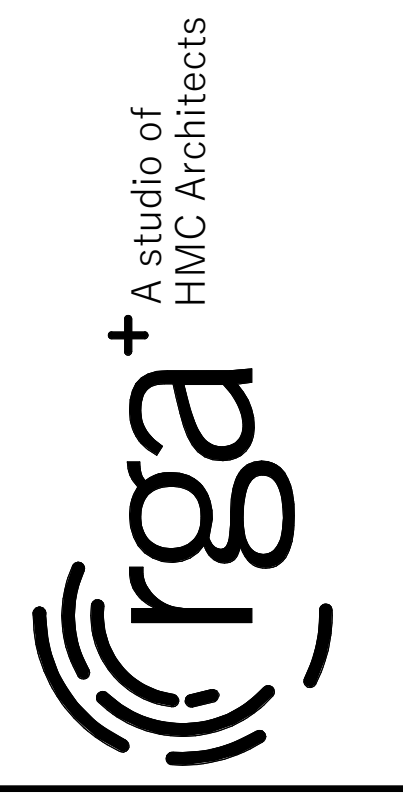

ELECTRICAL INFORMATION - RECTANGULAR HIP

ICON'S STANDARD ELECTRICAL IS DESIGNED TO ACCOMMODATE Ø1/2" CONDUIT WITH A Ø3" INLET HOLE ON THE BOTTOM OF EACH COLUMN. THE CONDUIT PATHWAY RUNS THROUGH THE COLUMN, RAFTER, AND RIDGE BEAM THROUGH ALL BOLTED CONNECTIONS AS SHOWN. IF YOU HAVE SPECIAL ELECTRICAL REQUIREMENTS, PLEASE OUTLINE ANY CHANGES BELOW AS DESCRIBED.

PLEASE NOTE: DESIGN LIMITATIONS ON HOLE/CUTOUT SIZES MAY APPLY. ICON WILL REACH OUT TO DISCUSS ANY SUCH LIMITATIONS AS NEEDED.

NOTE: ICON SHELTER FRAME IS NOT UL LISTED TO ACT AS A CONDUIT FOR ELECTRICAL WIRING. CONSULT LOCAL BUILDING CODES WHEN PLANNING YOUR ELECTRICAL SYSTEM.

PRELIMINARY: NOT FOR CONSTRUCTION

- STEPS:**
1. CONDUIT HOLE SIZE (DETAIL A)
 2. ELECTRICAL EXIT HOLES (DETAIL B)
 3. ELECTRICAL ACCESS & COVER PLATES (DETAIL C)
 4. ELECTRICAL CONDUIT PATHWAY (DETAIL D)

IF REQUIRED, PLEASE DRAW THE NECESSARY ELECTRICAL CONDUIT PATHWAY ON THE FRAME SHEET OF THIS PRELIMINARY.

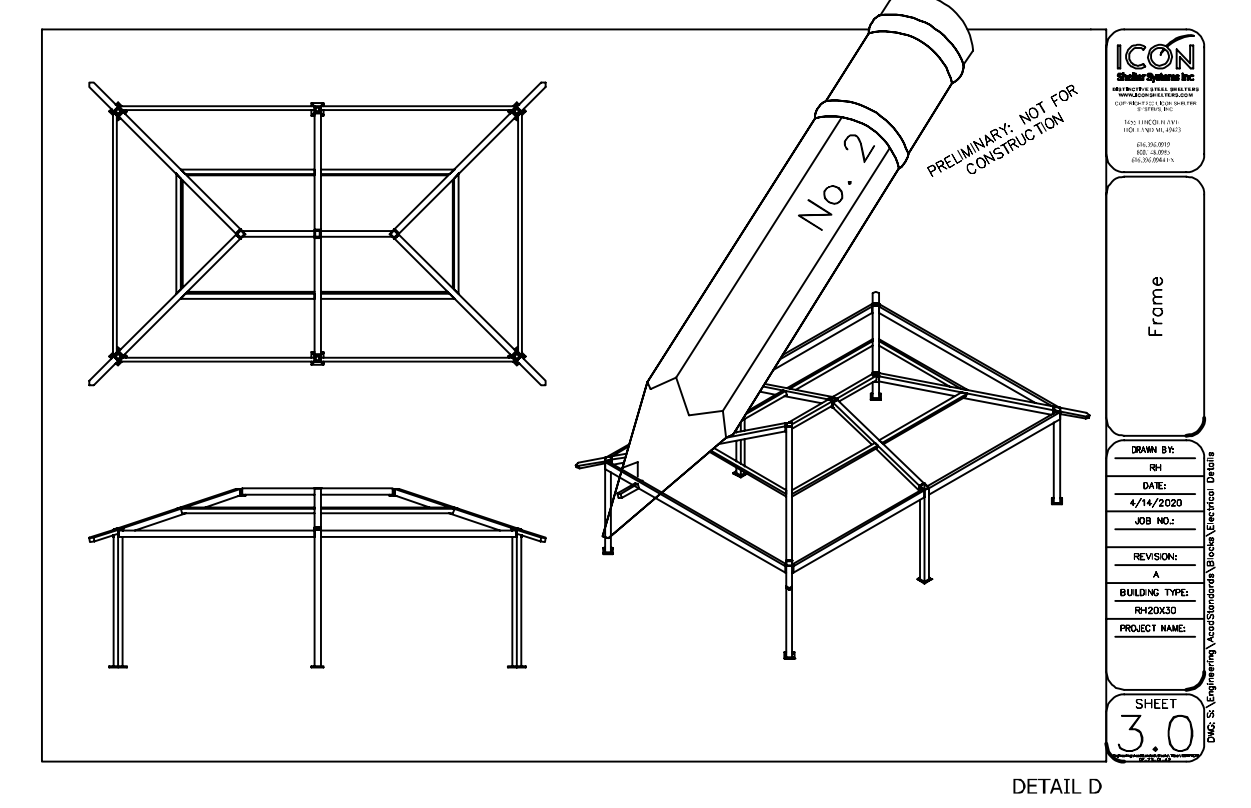

OPTIONAL EXIT HOLES
 IF REQUIRED, EXIT HOLES FOR LIGHTING, ETC. CAN BE PLACED IN THE RIDGE BEAM AND/OR CONNECTOR TUBE WITH 14ga COVER PLATE AS SHOWN (CHARGES APPLY). USE FRAME SHEET OF THIS PRELIMINARY TO SPECIFY REQUIRED EXIT HOLE LOCATIONS AND SIZE.

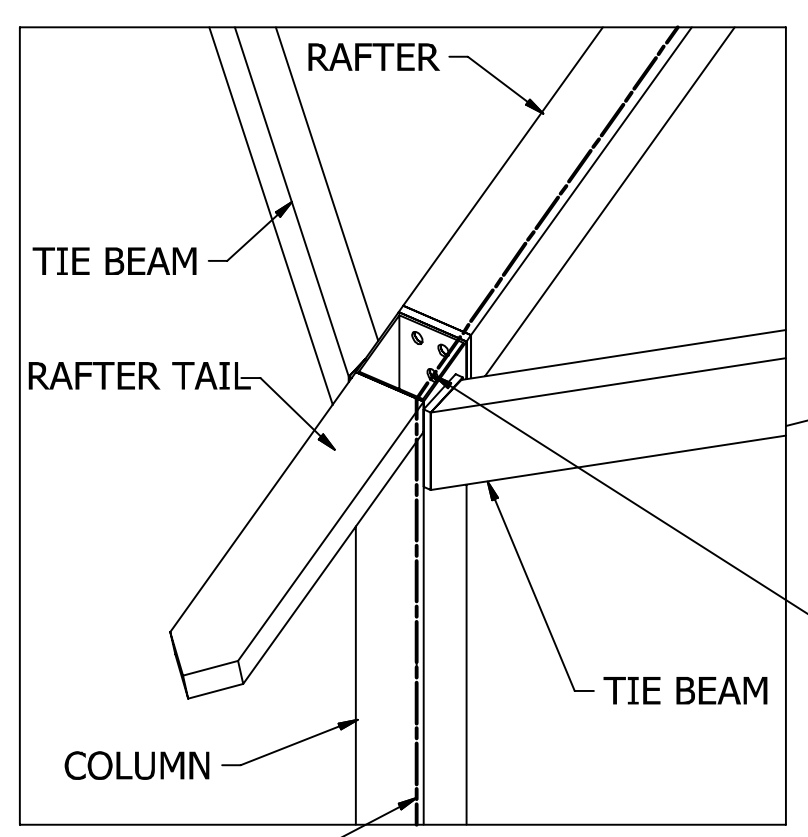
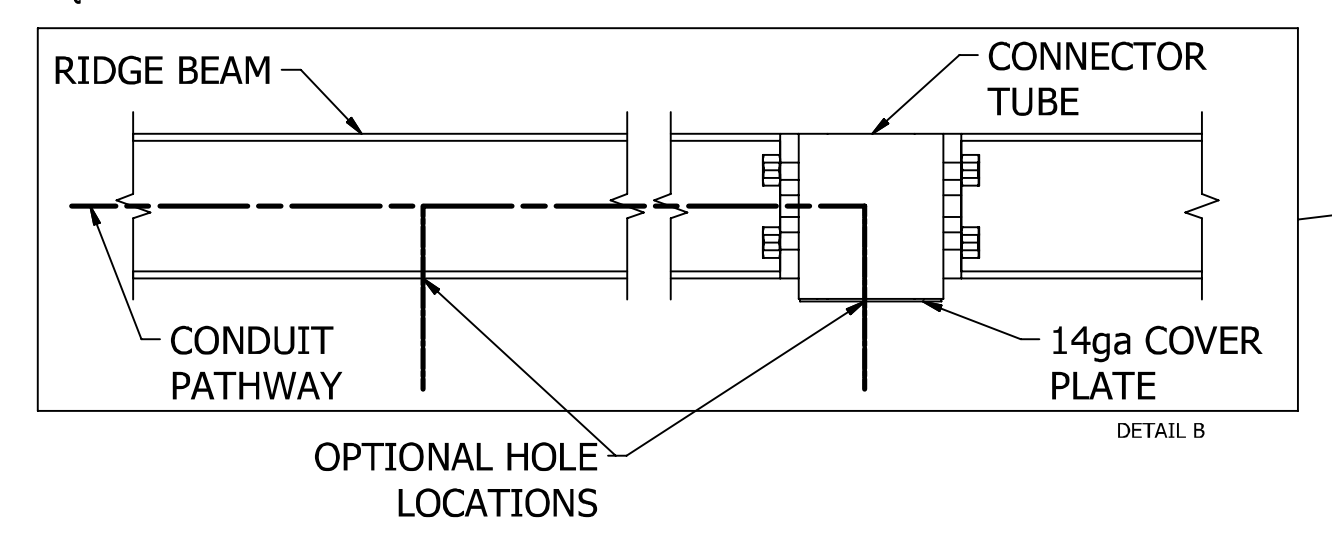

ICON PROVIDES A MINIMUM OF (1) 3/4" HOLE AT EACH CONNECTION FOR 1/2" CONDUIT. IF APPLICABLE, PLEASE SPECIFY REQUIRED CONDUIT SIZE: (CHARGES APPLY)

- 3/4" CONDUIT (1" HOLES)
- 1" CONDUIT (1 1/4" HOLES)
- OTHER (PLEASE SPECIFY)

CONDUIT PATHWAY PROVIDED FOR EACH COLUMN.

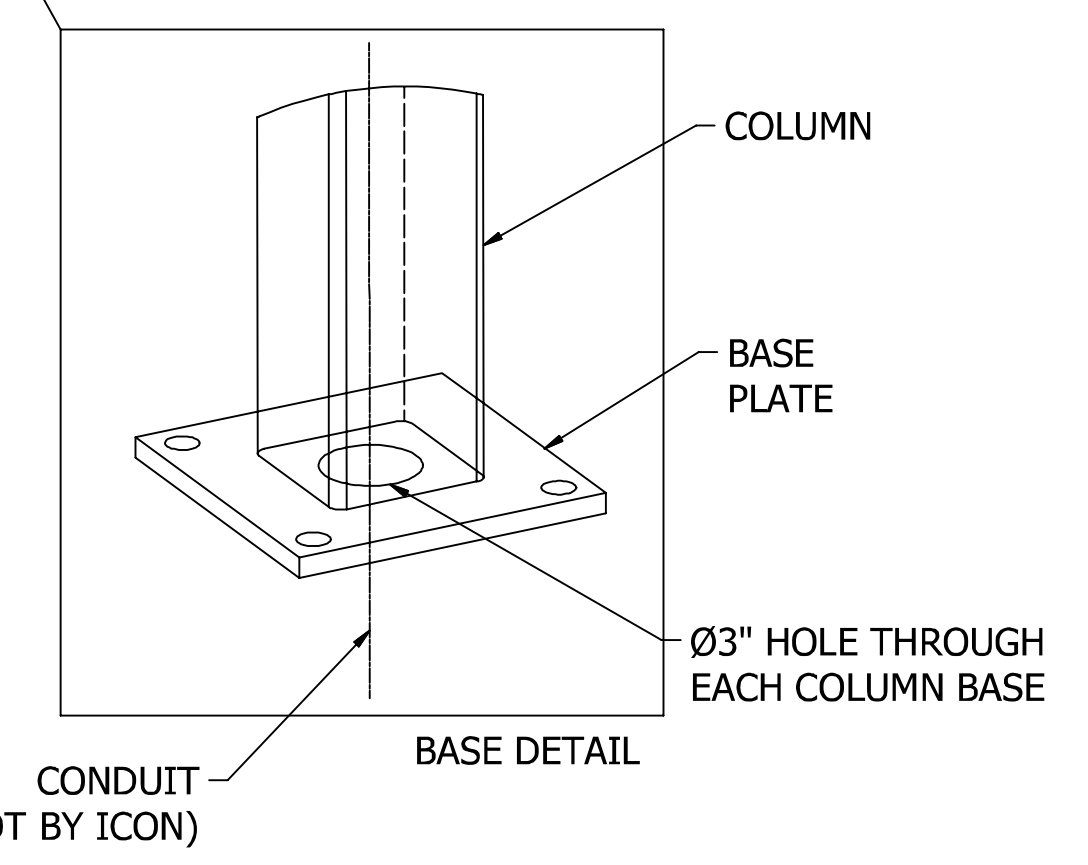

OPTIONAL CUTOUTS
 USE FRAME SHEET OF THIS PRELIMINARY TO SPECIFY REQUIRED CUTOUT LOCATIONS (CHARGES APPLY). SEE REQUIRED INFO BELOW

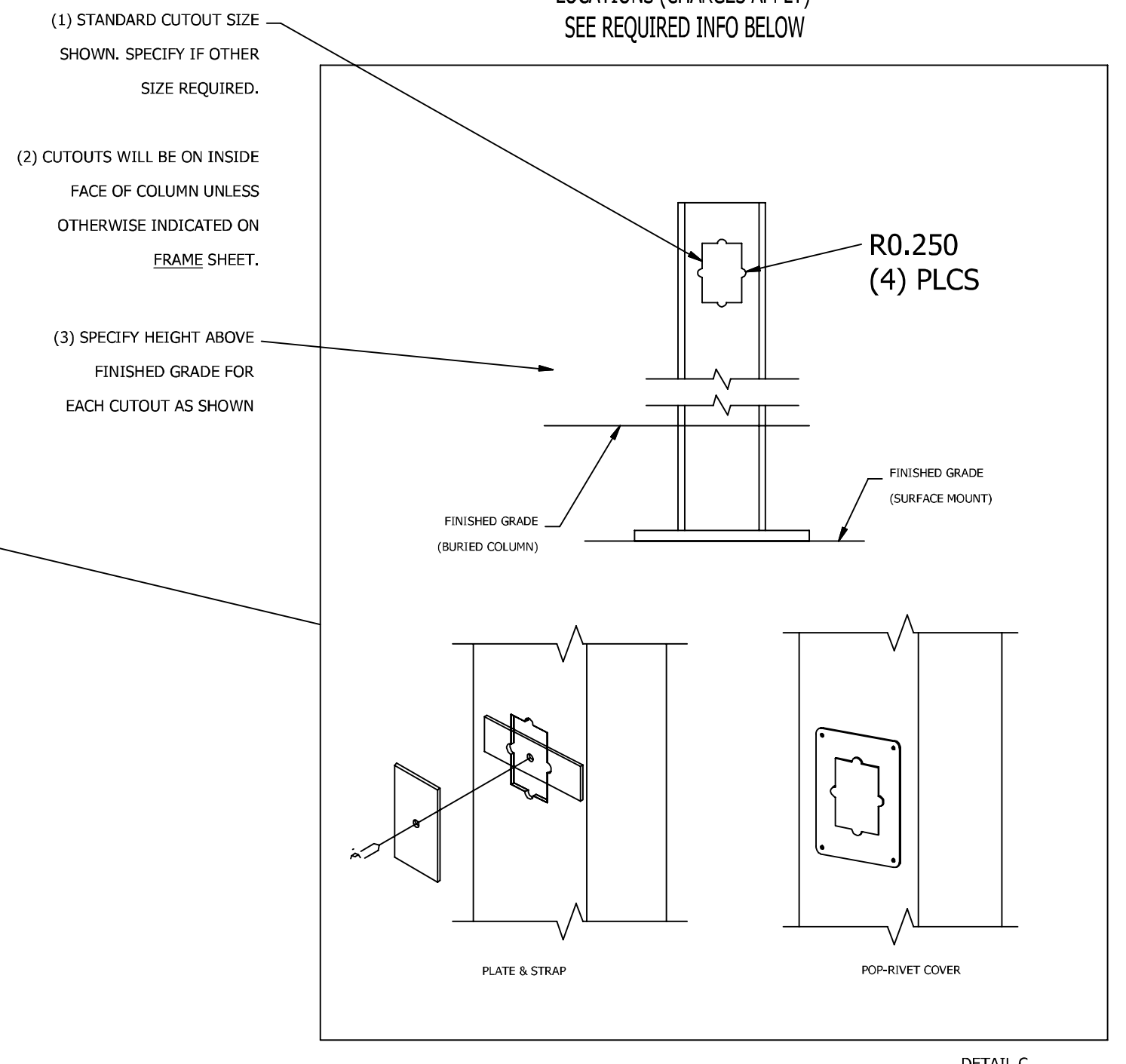

- (4) COVER PLATES PROVIDED UPON REQUEST (CHARGES APPLY)
 PLEASE SPECIFY TYPE AND QUANTITY REQUIRED:
- PLATE & STRAP
 - POP-RIVET COVER PLATE
- HOW MANY REQUIRED? _____

NOTE: BUILDING DEPICTED ON THIS SHEET FOR ILLUSTRATION PURPOSES ONLY. ACTUAL LAYOUT AND FRAME MEMBER QUANTITIES VARY BY DESIGN. PLEASE REFER TO ELEVATION AND FRAME SHEETS IN THIS PRELIMINARY FOR ORDER-SPECIFIC CONFIGURATION.

ICON STD	R4/OSA-PC
DRAWN BY	ANGEL
DATE	4/2/2021
REV	
REV DATE	

JRMA
 ARCHITECTS ENGINEERS
 2200 SATORI ST. BERKELEY, CA 94707
 1714 24th STREET #114, SAN DIEGO, CA 92108
 WWW.JRMA.COM

PROFESSIONAL SEAL
 MICHAEL D. JOHNSON
 REGISTERED PROFESSIONAL ARCHITECT
 STATE OF CALIFORNIA
 No. 10000
 Exp. 07/29/2021

APPROVED
 DIR. OF THE STATE ARCHITECT
 APP: 04-20013-PC
 REVIEWED FOR
 SS PLS ACS CG
 DATE: 08/08/2021

ELECTRICAL ACCESS

ICON Shelter Systems Inc
 DISTINCTIVE STEEL SHELTERS
 WWW.ICONSHELTERS.COM
 COPYRIGHT 2004, ICON SHELTER SYSTEMS, INC.
 1455 LINCOLN AVE.
 HOLLAND MI, 49423
 616.396.0919
 800.748.0985
 616.396.0944 FX

LS5.0

PRE-CHECK (PC) DOCUMENT
 Code: 2019 CBC
 A separate project application for construction is required.

PRINTED ON :

SHADE STRUCTURE AT ALICE BIRNEY PUBLIC WALDORF K-8 SCHOOL
 SACRAMENTO CITY UNIFIED SCHOOL DISTRICT
 SACRAMENTO, CA

Revision

Copyright © 2021 Rainforth Grau Architects. All rights reserved. Reproduction of these plans, either in whole or in part, including any form of copying and/or preparation of derivative works thereof, for any reason without prior written permission, is strictly prohibited.

ELECTRICAL ACCESS

PROJECT NO. 21-1504.01
 DATE: 4/7/22
 SHEET

LS5.0

AD0.12

EXISTING TOPOGRAPHY

- = PROPERTY LINE
- - - = CENTERLINE
- - - = EASEMENT
- ⊙ = PROPERTY CORNER FOUND AS NOTED
- ⊙ = PROPERTY CORNER NOTHING FOUND OR SET
- △123 = TEMPORARY BENCHMARK (SEE TBM LIST FOR INFO)
- = SWALE OR DRAINAGE FLOW
- = DRAINAGE FLOW
- = FENCE (TYPE NOTED)
- = TREE (SIZE/TYPE INDICATED)
- = SLOPE
- 100 = CONTOUR
- = CONCRETE SURFACE
- = EDGE OF ASPHALT
- = EDGE OF BUILDING
- = SIGN
- = POST OR BOLLARD
- 99.99 = GROUND ELEVATION
- 99.99 = HARD SURFACE ELEVATION

EXISTING UTILITIES

- 12"SD = STORM DRAIN LINE (SIZE & DIRECTION OF FLOW)
- 12"SD = STORM DRAIN LINE (RECORD INFORMATION)
- 12"SD = STORM DRAIN LINE (UNDERGROUND LOCATING)
- ⊙ = STORM DRAIN MANHOLE
- = STORM DRAIN CLEANOUT
- = DROP INLET
- ⊙ = AREA DRAIN
- HDPE = RAIN WATER LEADER
- DS = DOWNSPOUT
- 12"SS = SANITARY SEWER LINE (SIZE & DIRECTION OF FLOW)
- 12"SS = SANITARY SEWER LINE (RECORD INFORMATION)
- 12"SS = SANITARY SEWER LINE (UNDERGROUND LOCATING)
- ⊙ = SANITARY SEWER MANHOLE
- = SANITARY SEWER CLEANOUT
- W— = WATER LINE (SIZE INDICATED)
- W— = WATER LINE (RECORD INFORMATION)
- W— = WATER LINE (UNDERGROUND LOCATING)
- ⊙ = WATER MANHOLE
- ⊙ = WATER VALVE
- ⊙ = WATER METER
- ⊙ = WATER BOX
- ⊙ = IRRIGATION CONTROL VALVE
- ⊙ = FIRE HYDRANT
- ⊙ = BACKFLOW PREVENTER
- ⊙ = SPRINKLER
- ⊙ = HOSE BIBB
- OH—E— = OVERHEAD ELECTRIC LINE
- E— = UNDERGROUND ELECTRIC LINE
- E— = UNDERGROUND ELECTRIC LINE (RECORD INFORMATION)
- E— = UNDERGROUND ELECTRIC LINE (UNDERGROUND LOCATING)
- ⊙ = ELECTRIC MANHOLE
- ⊙ = UTILITY POLE (WITH GUY WIRE)
- ⊙ = ELECTRIC METER
- ⊙ = ELECTRIC BOX
- ⊙ = STREET LIGHTING BOX
- ⊙ OR ⊙ = LIGHT STANDARD
- ⊙ = SIGNAL LIGHT
- ⊙ = FLOOD LIGHT
- ⊙ = ELECTRICAL OUTLET
- G— = GAS LINE (SIZE INDICATED)
- G— = GAS LINE (RECORD INFORMATION)
- G— = GAS LINE (UNDERGROUND LOCATING)
- ⊙ = GAS MANHOLE
- ⊙ = GAS VALVE
- ⊙ = GAS METER
- T— = TELEPHONE LINE
- T— = TELEPHONE LINE (RECORD INFORMATION)
- T— = TELEPHONE LINE (UNDERGROUND LOCATING)
- ⊙ = STORM DRAIN BOX
- ⊙ = TRAFFIC SIGNAL BOX

TBM LIST

NUMBER	DESCRIPTION	NORTHING	EASTING	FLEV
1	CPS CHISELED "+"	10498.58	9946.74	16.08
2	CPF BM EL=16.363	10744.01	10246.87	16.36
3	CPS CHISELED "+"	10598.95	10067.79	17.13
4	CPS CHISELED "+"	10534.56	10116.70	17.21
5	CPS CHISELED "+"	10479.18	10128.93	17.15
6	CPS CHISELED "+"	10402.50	10135.08	17.28
7	CPS CHISELED "+"	10331.94	10167.78	17.10
8	CPS CHISELED "+"	10348.64	10011.89	17.52
9	CPS CHISELED "+"	10527.76	9867.74	15.80
10	CPS CHISELED "+"	10551.34	9624.36	13.18
11	CPS CHISELED "+"	10663.82	9975.35	17.18
12	CPS CHISELED "+"	10592.96	10378.02	17.91
13	CPS CHISELED "+"	10574.46	10295.59	17.18
14	CPS CHISELED "+"	10559.85	10230.78	17.18
15	CPS CHISELED "+"	10464.93	10321.45	17.13
16	CPS CHISELED "+"	10457.04	10447.83	18.74
17	CPS CHISELED "+"	10756.37	10050.32	14.67

CIVIL ABBREVIATIONS AND LEGEND

- ABBREVIATIONS**
- NOTE: NOT ALL ABBREVIATIONS MAY BE USED ON THESE PLANS.
- AB AGGREGATE BASE
 - AC ASPHALTIC CONCRETE
 - AD AREA DRAIN
 - APN ASSESSOR'S PARCEL NUMBER
 - ARV AIR RESTRICTING VALVE
 - ASB AGGREGATE SUB-BASE
 - BO BLOW-OFF VALVE
 - BV BUTTERFLY VALVE
 - BW BACK OF WALK
 - C/L CENTERLINE
 - CB CATCH BASIN
 - CL CLASS
 - CM CORRUGATED METAL PIPE
 - CTV CABLE TELEVISION
 - CO CLEANOUT
 - COMM COMMUNICATION
 - CONC CONCRETE
 - CONST. CONSTRUCTION
 - CR CURB RETURN
 - CS CONCRETE SURFACE
 - DC DOUBLE CHECK VALVE
 - DDC DOUBLE DETECTOR CHECK VALVE
 - DG DECOMPOSED GRANITE
 - DI DROP INLET
 - DIA DIAMETER
 - DIP DUCTILE IRON PIPE
 - DWG DRAWING
 - DOWN DOWNPOUT
 - E ELECTRIC
 - EP EDGE OF PAVEMENT
 - ESMT EASEMENT
 - EX EXISTING
 - FS FIRE SERVICE LINE
 - FDC FIRE DEPARTMENT CONNECTION
 - FL FLOWLINE
 - FM SANITARY SEWER FORCE MAIN
 - FN FINISHED FLOOR ELEVATION
 - FH FIRE HYDRANT
 - GR GRATE ELEVATION
 - GRD GRADE ELEVATION
 - GV GATE VALVE
 - HB HOSE BIBB
 - HBD HEADER BOARD
 - HDPE HIGH DENSITY POLYETHYLENE PIPE
 - HP HIGH POINT
 - NW PIPE INVERT ELEVATION
 - JP JOINT UTILITY POLE
 - LF LINEAL FEET
 - LIP LIP OF GUTTER
 - LT LEFT
 - MS MOWSTRIP
 - NTS NOT TO SCALE
 - OH OVERHEAD
 - CH PORTLAND CEMENT CONCRETE
 - PD PLANTER DRAIN
 - PV POST INDICATOR VALVE
 - PL PROPERTY LINE
 - PP POWER POLE
 - PUE PUBLIC UTILITY EASEMENT
 - PVC POLYVINYL CHLORIDE
 - RCP REINFORCED CONCRETE PIPE
 - R RADIUS
 - MANHOLE RIM ELEVATION (SOLID COVER)
 - RP REDUCED PRESSURE BACKFLOW PREVENTER
 - RT RIGHT OF WAY
 - SCH SCHEDULE
 - SD STORM DRAIN
 - SDMH STORM DRAIN MANHOLE
 - SC SUBGRADE ELEVATION
 - SS SANITARY SEWER
 - SSMH SANITARY SEWER MANHOLE
 - STD STANDARD
 - S/W SIDEWALK
 - T TELEPHONE
 - TC TOP OF CURB
 - TD TRENCH DRAIN
 - TDCB TRENCH DRAIN CATCH BASIN
 - TP TELEPHONE POLE
 - TR TOP OF RAMP ELEVATION
 - TRW TOP OF RETAINING WALL
 - TSW TOP OF SEAT WALL
 - TW TOP OF WALK ELEVATION
 - U UTILITY
 - UG UNDERGROUND
 - UN UNLESS OTHERWISE NOTED
 - VCP VITRIFIED CLAY PIPE
 - W WATER
 - W/ WITH
 - W/O WITHOUT
 - WW WATER VALVE
- LEGEND**
- NOTE: NOT ALL SYMBOLS MAY BE USED ON THESE PLANS.
- PROPOSED GRADING & DRAINAGE SYMBOLS:**
- 8"SD STORM DRAIN LINE (SIZE AND FLOW SHOWN)
 - STORM DRAIN MANHOLE (SDMH)
 - CATCH BASIN (CB)
 - DROP INLET (DI)
 - AREA DRAIN (AD)
 - PLANTER DRAIN (PD) OR FLOOR DRAIN (FD)
 - STORM DRAIN CLEANOUT
 - 99.99 ELEVATION
 - FF=100.00 FINISHED FLOOR ELEVATION
 - PAD=99.33 BUILDING PAD ELEVATION
 - CONCRETE SIDEWALK
 - GRADED DIRECTION FOR DRAINAGE FLOW
 - SWALE
 - SLOPE
 - ⊗ TREE TO BE REMOVED
 - RETAINING WALL
- PROPOSED SANITARY SEWER SYMBOLS:**
- 8"SS SANITARY SEWER LINE (SIZE AND FLOW SHOWN)
 - SANITARY SEWER MANHOLE (SSMH)
 - SEWER CLEANOUT FLUSHER BRANCH
- PROPOSED WATER SYMBOLS:**
- 8" W WATER LINE & SIZE
 - 8" FS FIRE LINE & SIZE
 - 8" DW DOMESTIC WATER LINE & SIZE
 - 8" RW RECLAIMED WATER LINE & SIZE
 - 8" IRR IRRIGATION SERVICE LINE & SIZE
 - 8" NP NON POTABLE WATER LINE & SIZE
 - 8" SP FIRE SPRINKLER SERVICE LINE & SIZE
 - GATE VALVE
 - WATER METER
 - FIRE HYDRANT ASSEMBLY
 - FIRE DEPARTMENT CONNECTION
 - DETECTOR CHECK VALVE
 - REDUCED PRESSURE BACKFLOW PREVENTER
 - BUTTERFLY VALVE
 - AIR RELEASE VALVE + SIZE
 - BLOW-OFF VALVE + SIZE
 - POST INDICATOR VALVE

DEMOLITION GENERAL NOTES

- IN THE EVENT THAT ANY UNUSUAL CONDITIONS NOT COVERED BY THE GEOTECHNICAL INVESTIGATION REPORT OR ARE ENCOUNTERED DURING GRADING OPERATIONS THE GEOTECHNICAL ENGINEER AND THE ARCHITECT SHALL BE IMMEDIATELY NOTIFIED FOR DIRECTIONS.
- NO BURNING OR BLASTING SHALL BE PERMITTED.
- ADDITIONAL DEMOLITION INFORMATION MAY BE SHOWN ON THE GRADING, DRAINAGE, AND UTILITY PLANS, AND THOSE PLANS PREPARED BY OTHER DISCIPLINES FOR THIS PROJECT.
- ALL DEMOLISHED ITEMS SHALL BE DISPOSED OF OFFSITE AT A SUITABLE, LEGAL, DUMP SITE OR OTHER FACILITY.
- ALL DISPOSED OF MATERIALS SHALL BE RECYCLED IF POSSIBLE.
- THE TYPES, LOCATIONS, SIZES AND/OR DEPTHS OF EXISTING UNDERGROUND UTILITIES AS SHOWN IN THESE PLANS WERE OBTAINED FROM SOURCES OF VARYING RELIABILITY. THE CONTRACTOR IS CAUTIONED THAT ONLY ACTUAL EXCAVATION WILL REVEAL THE TYPES, EXTENT, SIZES, LOCATIONS, AND DEPTHS OF SUCH UNDERGROUND UTILITIES. A REASONABLE EFFORT HAS BEEN MADE TO LOCATE AND DELINEATE ALL KNOWN UNDERGROUND UTILITIES. HOWEVER, WARREN CONSULTING ENGINEERS CAN ASSUME NO RESPONSIBILITY FOR THE COMPLETENESS OR ACCURACY OF ITS DELINEATION OF SUCH UNDERGROUND UTILITIES, NOR FOR THE EXISTENCE OF OTHER BURIED OBJECTS OR UTILITIES WHICH MAY BE ENCOUNTERED BUT WHICH ARE NOT SHOWN ON THESE PLANS. THE CONTRACTOR OR ANY SUBCONTRACTOR FOR THIS CONTRACT SHALL NOTIFY MEMBERS OF UNDERGROUND SERVICE ALERT (USA) TWO (2) WORKING DAYS IN ADVANCE OF PERFORMING ANY EXCAVATION WORK BY CALLING TOLL FREE 1-800-227-2600, OR 811.
- THE SCHOOL DISTRICT SHALL HAVE SALVAGE RIGHTS TO ANY DEMOLISHED ITEMS SHOWN HEREON. THE CONTRACTOR SHALL GIVE THE DISTRICT NOTICE 7 DAYS PRIOR TO THE START OF DEMOLITION. THE DISTRICT SHALL MOVE ANY RETAINED ITEMS OUT OF THE CONTRACTORS WORK AREA, UNLESS ANOTHER ARRANGEMENT IS MADE WITH THE CONTRACTOR. ANY REMAINING ITEMS BECOME THE PROPERTY OF THE CONTRACTOR AND SHALL BE REMOVED FROM THE SITE. ANY ITEMS NOT SHOWN FOR REMOVAL SHALL REMAIN AND SHALL BE PROTECTED FROM DAMAGE DURING CONSTRUCTION TO A REASONABLE EXTENT.
- EXISTING UTILITY STRUCTURES IN AREAS OF NEW PAVING SHALL BE REMOVED AND REPLACED WITH NEW BOX/COVER AT NEW GRADE UNLESS SPECIFICALLY NOTED OTHERWISE.
- ITEMS OUTSIDE THE LIMITS OF DEMOLITION SHALL REMAIN AND BE PROTECTED FROM DAMAGE DURING CONSTRUCTION.
- EXISTING UTILITY STRUCTURES AND PIPING NOT SHOWN ON DEMOLITION PLAN TO BE REMOVED SHALL REMAIN AND BE PROTECTED.

UTILITY VERIFICATION NOTE

PRIOR TO THE START OF CONSTRUCTION, VERIFY AND POTHOLE ALL UTILITY POINTS OF CONNECTION FOR LOCATION, DEPTH, AND SIZE. IF CONFLICT IS FOUND, CONTACT THE ENGINEER IMMEDIATELY FOR DIRECTION.

IRRIGATION DEMOLITION NOTE

WITHIN LANDSCAPE AREAS TO BE DEMOLISHED THERE MAY BE EXISTING IRRIGATION LINES NOT SHOWN ON THIS PLAN. CONTRACTOR SHALL REMOVE LATERAL LINES AND HEADS ENCOUNTERED. MAIN LINES AND CONTROL WIRES MAY ONLY BE REMOVED PROVIDED THAT ROUTING IS KNOWN AND REMOVAL WILL NOT DEACTIVATE AN IRRIGATION SYSTEMS INTENDED TO REMAIN. IF CONFLICT IS FOUND, CONTACT THE ENGINEER FOR DIRECTION.

GENERAL NOTES

- THE TYPES, LOCATIONS, SIZES, AND/OR DEPTHS OF EXISTING UNDERGROUND UTILITIES AS SHOWN ON THESE PLANS WERE OBTAINED FROM SOURCES OF VARYING RELIABILITY. THE CONTRACTOR IS CAUTIONED THAT ONLY ACTUAL EXCAVATION WILL REVEAL THE TYPES, EXTENT, SIZES, LOCATIONS AND DEPTHS OF SUCH UNDERGROUND UTILITIES. A REASONABLE EFFORT HAS BEEN MADE TO LOCATE AND DELINEATE ALL KNOWN UNDERGROUND UTILITIES. HOWEVER, WARREN CONSULTING ENGINEERS CAN ASSUME NO RESPONSIBILITY FOR THE COMPLETENESS OR ACCURACY OF ITS DELINEATION OF SUCH UNDERGROUND UTILITIES, NOR FOR THE EXISTENCE OF OTHER BURIED OBJECTS OR UTILITIES WHICH MAY BE ENCOUNTERED BUT WHICH ARE NOT SHOWN ON THESE PLANS. THE CONTRACTOR OR ANY SUBCONTRACTOR FOR THIS CONTRACT SHALL NOTIFY MEMBERS OF UNDERGROUND SERVICE ALERT (USA) TWO (2) WORKING DAYS IN ADVANCE OF PERFORMING ANY EXCAVATION WORK BY CALLING TOLL FREE 1-800-227-2600, OR 811.
- WARREN CONSULTING ENGINEERS, INC. (WCE) ASSUMES NO RESPONSIBILITY FOR ERRORS IN PHYSICAL LOCATION OF IMPROVEMENTS, HORIZONTAL OR VERTICAL. IN ADDITION, ANY SUCH ERRORS IN PHYSICAL LOCATION MAY AFFECT THE INTENDED DESIGN OF SUCH IMPROVEMENTS AND WCE CANNOT BE HELD RESPONSIBLE FOR SUCH CONDITIONS WHICH ARE A RESULT OF ERRORS IN SURVEYING, OR IMPROPER CONSTRUCTION.
- IF SUBSURFACE CULTURAL RESOURCES, REMAINS, AND/OR ARTIFACTS ARE UNCOVERED DURING PROJECT CONSTRUCTION, ALL WORK IN THE VICINITY SHALL BE STOPPED UNTIL SUCH ITEMS CAN BE ASSESSED BY AN APPROPRIATE MEMBER OF THE COUNTY ENVIRONMENTAL IMPACT SECTION STAFF.
- CONTRACTOR AGREES THAT HE/SHE SHALL ASSUME SOLE AND COMPLETE RESPONSIBILITY FOR JOB SITE CONDITIONS DURING THE COURSE OF CONSTRUCTION OF THIS PROJECT, INCLUDING SAFETY OF ALL PERSONS AND PROPERTY; THAT THIS REQUIREMENT SHALL APPLY CONTINUOUSLY AND SHALL NOT BE LIMITED TO NORMAL WORKING HOURS; AND THAT THE CONTRACTOR SHALL DEFEND, INDEMNIFY AND HOLD THE OWNER AND ENGINEER HARMLESS FROM ANY AND ALL LIABILITY, REAL OR ALLEGED, IN CONNECTION WITH THE PERFORMANCE OF WORK ON THIS PROJECT, EXCEPTING FOR LIABILITY ARISING FROM THE SOLE NEGLIGENCE OF THE OWNER OR ENGINEER.
- THE CONTRACTOR SHALL OBTAIN AN EXCAVATION PERMIT FROM THE STATE OF CALIFORNIA DEPARTMENT OF INDUSTRIAL SAFETY FOR ALL EXCAVATIONS OF 5 FEET OR MORE IN DEPTH.
- IT SHALL BE THE CONTRACTOR'S RESPONSIBILITY TO MAKE ALL NECESSARY PRE-BID AND PRE-CONSTRUCTION SITE INSPECTION, AND/OR OBSERVATIONS ON THE SITE TO PRE-DETERMINE ALL HIS/HER MEANS AND METHODS NECESSARY TO COMPLETE THE IMPROVEMENTS SHOWN ON THESE PLANS AND PER THE PROJECT SPECIFICATIONS. IT IS THE CONTRACTOR'S RESPONSIBILITY TO DETERMINE, AND INCLUDE IN HIS/HER CONTRACT, ALL MEANS AND METHODS NECESSARY TO PERFORM A COMPLETE AND ACCEPTABLE JOB.
- WHERE IMPROVEMENTS LIE WITHIN AN EXISTING DEVELOPED AREA, CONTRACTOR SHALL USE CAUTION WHEN ACCESSING THE SITE THROUGH THESE EXISTING IMPROVEMENTS. IT IS THE CONTRACTOR'S RESPONSIBILITY TO PROTECT ANY SUCH EXISTING IMPROVEMENTS OUTSIDE THE PROJECT BOUNDARY, OR EXISTING IMPROVEMENTS WITHIN THE BOUNDARY WHICH ARE TO REMAIN. PROPER PRECAUTIONS SHALL BE PROVIDED AND MAINTAINED THROUGHOUT CONSTRUCTION. ANY DAMAGE SHALL BE REPAIRED OR REPLACED TO THE SATISFACTION OF THE OWNER.
- IT IS THE RESPONSIBILITY OF THE CONTRACTOR TO KEEP DETAILED RECORDS OF MINOR CHANGES OR ADJUSTMENTS MADE DURING CONSTRUCTION (WHICH WERE NOT FORMALLY ISSUED). UPON PROJECT COMPLETION, THESE RECORDS AND/OR INFORMATION SHALL BE PROVIDED TO THE OWNER AND WARREN CONSULTING ENGINEERS, INC. UNLESS AN OFFICIAL "AS-BUILT" SET OF PLANS IS A REQUIREMENT OF THE CONTRACT. IF AS-BUILT PLANS ARE A REQUIREMENT OF THE CONTRACT, REFER TO SPECIFICATIONS FOR AS-BUILT DELIVERABLE REQUIREMENTS.
- IN VEHICULAR PATHWAYS, EXISTING ASPHALTIC AND/OR CONCRETE SURFACES SHALL BE CUT TO A NEAT AND STRAIGHT LINE, PARALLEL OR PERPENDICULAR TO THE VEHICULAR TRAVELED PATH. THIS IS TYPICALLY THE ROADWAY CENTERLINE, BUT MAY VARY. THAT SAWCUT EDGE SHALL BE PROTECTED FROM DAMAGE DURING CONSTRUCTION SO A CLEAR EDGE IS MAINTAINED. IF EDGE IS DAMAGED, A NEW SAW CUT WILL BE REQUIRED. THE EXPOSED EDGE SHALL BE "TACKED" WITH EMULSION PRIOR TO PAVING.
- NO BURNING OR BLASTING SHALL BE ALLOWED ONSITE UNLESS SPECIFICALLY ADDRESSED ON PLANS, OR SPECIFICALLY APPROVED AND COORDINATED WITH THE ARCHITECT, ENGINEER, AND LOCAL AGENCY OR OTHER ADMINISTRATIVE AUTHORITY.
- SUBGRADE AND RESULTING FINISHED GRADE SHALL BE CONSTRUCTED SMOOTH AND UNIFORM BETWEEN SPOT ELEVATIONS, CONTOURS OR OTHER STRUCTURE ELEVATIONS SHOWN ON GRADING OR OTHER PLANS. NO MOUNDS, RUTS, DEPRESSIONS OR OTHER GRADING DEFICIENCIES WILL BE ALLOWED UNLESS SPECIFICALLY SHOWN ON PLANS.
- ON NEW WATER SYSTEMS, SERVICE LATERALS SHALL BE MADE USING APPROPRIATE "TTEE" AND "WYE" FITTINGS. SADDLE TAPS WILL ONLY BE ALLOWED WHEN MAKING CONNECTIONS TO EXISTING WATER MAINS.
- CURING COMPOUND SHALL BE APPLIED IN A CONTINUOUS SOLID WET FLOWING COAT. ANY "SPOTTY" APPLICATIONS SHALL BE RECOATED IMMEDIATELY. APPLICATION SHALL BE INSPECTED BY PROJECT INSPECTOR DURING APPLICATION.
- EMBEDMENT OF FEATURES IN CONCRETE PAVING, CURBS, OR WALLS, SUCH AS SQUARE OR ROUND TUBING, POSTS, OR COLUMNS, STEEL BOLTED PLATES, OR OTHER STRUCTURES, SHALL REQUIRE ADDITIONAL SCORE OR EXPANSION JOINTS TO PREVENT UNCONTROLLED CRACKING. THOSE ADDITIONAL JOINTS MAY OR MAY NOT BE SPECIFICALLY SHOWN ON PLANS BUT SHALL BE PROVIDED BY THE CONTRACTOR.
- EMBEDMENT OF FEATURES IN CONCRETE PAVING, CURBS, OR WALLS, SUCH AS SQUARE OR ROUND TUBING, POSTS, OR COLUMNS, STEEL BOLTED PLATES, OR OTHER STRUCTURES, SHALL REQUIRE ADDITIONAL SCORE OR EXPANSION JOINTS TO ALLOW FOR SUCH STRUCTURE. THAT REBAR ADJUSTMENT MAY NOT BE SPECIFICALLY SHOWN ON PLANS.
- NO MORE THAN 1 GALLON OF WATER PER YARD OF CONCRETE CAN BE ADDED TO THE TRUCK AFTER ARRIVAL TO PROJECT SITE. THE ADDITION OF WATER CAN ONLY BE ADDED UNDER THE SUPERVISION OF THE CONCRETE INSPECTOR OR LABORATORY TECHNICIAN.
- WHEN PUMPING CONCRETE FOR PLACEMENT, ABSOLUTELY NO WATER IS TO BE ADDED TO PUMP HOPPER. ANY WATER ADDED TO HOPPER WILL BE REASON FOR CONCRETE REJECTION AT THE CONTRACTORS EXPENSE.
- ALL CONTRACTION/CONSTRUCTION JOINTS "CJ" SHALL BE 1/4 THE SLAB THICKNESS DEEP, BUT NO LESS THAN 1" FOR CONTROLLING OF CRACKING. CONTRACTOR SHALL EXERCISE CAUTION WHEN FINAL TROWELING OF CONCRETE SO AS NOT TO FILL IN THESE JOINTS WITH CONCRETE CREAM. ANY CRACKS OUTSIDE OF JOINTS WHICH WERE CONSTRUCTED LESS THAN 1" DEEP, SHALL BE CAUSE FOR CONCRETE SLAB(S) TO BE REMOVED AND REPLACE AT CONTRACTORS EXPENSE.
- ANY SCORED BOARDS SET WITHIN CONCRETE SLABS SHALL BE AN "OVERHEAD SCREED" SO THERE IS NO INTERFERENCE WITH THE PLACEMENT AND ALIGNMENT OF SLAB REINFORCING.
- 3-1/2" FELT JOINTS WILL NOT BE ACCEPTED. PROVIDE A FULL 4" FELT JOINT FOR 4" SLAB CONSTRUCTION, AND A 6" FELT JOINT FOR A 6" SLAB CONSTRUCTION.
- SHOULD ANY SHRINKAGE CRACKS OCCUR OUTSIDE OF EITHER THE EXPANSION JOINTS OR CRACK CONTROL JOINTS, THEN THE CONCRETE SLAB SHALL BE SAWCUT AT THE NEAREST JOINTS ON EACH SIDE OF THE CRACK AND THE CONCRETE SECTION SHALL BE, REMOVED AND REPLACED. NEW CONCRETE SHALL BE DOWELED INTO EXISTING CONCRETE PER DRAWING DETAIL.
- ALL AREAS DISTURBED BY GRADING OPERATIONS WHETHER SHOWN ON THE DRAWINGS OR NOT SHALL BE HYDRO SEEDED UNLESS OTHERWISE NOTED. HYDRO SEEDING SHALL CONFORM TO LOCAL CITY/COUNTY STANDARDS.
- REPAIR OR PATCHING OF GALVANIZED METALS, SUCH AS AFTER WELDING GALVANIZED COMPONENTS, SHALL BE MADE USING A ZINC COMPOSITION "HOT STICK" APPLICATION PER ASTM A 780-01. GALVANIZING PAINTS WILL NOT BE ALLOWED.

GENERAL PAVING SURFACE NOTES:

- PROVIDE EQUIVALENT OF MEDIUM BROOM FINISH AT SLOPES UP TO 5.99%, TYPICAL PROVIDE EQUIVALENT OF HEAVY BROOM FINISH AT SLOPES 6% AND GREATER. REFER TO SPECIFICATIONS.
- ALL NEW PEDESTRIAN WALKWAYS (NON-RAMP) SHALL BE SLOPED NO GREATER THAN 2.0%, AND NO LESS THAN 0.75% IN ANY DIRECTION UNLESS SPECIFICALLY LABELED OTHERWISE. ALL CONCRETE SHALL MEET THE FOLLOWING SLOPE REQUIREMENTS:
 - NO GREATER THAN 5% SLOPE IN THE DIRECTION OF TRAVEL.
 - NO GREATER THAN 2% SLOPE CROSSING THE DIRECTION OF TRAVEL.
 - NO GREATER THAN 2% SLOPE IN ANY DIRECTION IN COURTYARD OR PLAZA AREAS.

CIVIL SHEET INDEX

- C0.1 CIVIL GENERAL NOTES AND ABBREVIATIONS
- C1.1 DEMOLITION PLAN
- C2.1 GRADING AND PAVING PLAN

LANDSCAPE/IRRIGATION NOTE:
GENERAL CONTRACTOR IS REQUIRED TO HIRE A LANDSCAPE SUBCONTRACTOR TO PERFORM ALL LANDSCAPE AND IRRIGATION REPAIRS.

811
Know what's below.
Call before you dig.

rga+
A studio of
HMC Architects

REGISTERED PROFESSIONAL ENGINEER
ANTHONY J. TASSANO
No. 14699
STATE OF CALIFORNIA

WCE
WARREN CONSULTING ENGINEERS, INC.
1117 WINDFELD WAY, SUITE 110
EL DORADO HILLS, CA 95762 | (916) 985-1870

SHADE STRUCTURE AT JOHN BIDWELL ELEMENTARY SCHOOL

SACRAMENTO CITY UNIFIED SCHOOL DISTRICT
SACRAMENTO, CA

CIVIL GENERAL NOTES AND ABBREVIATIONS

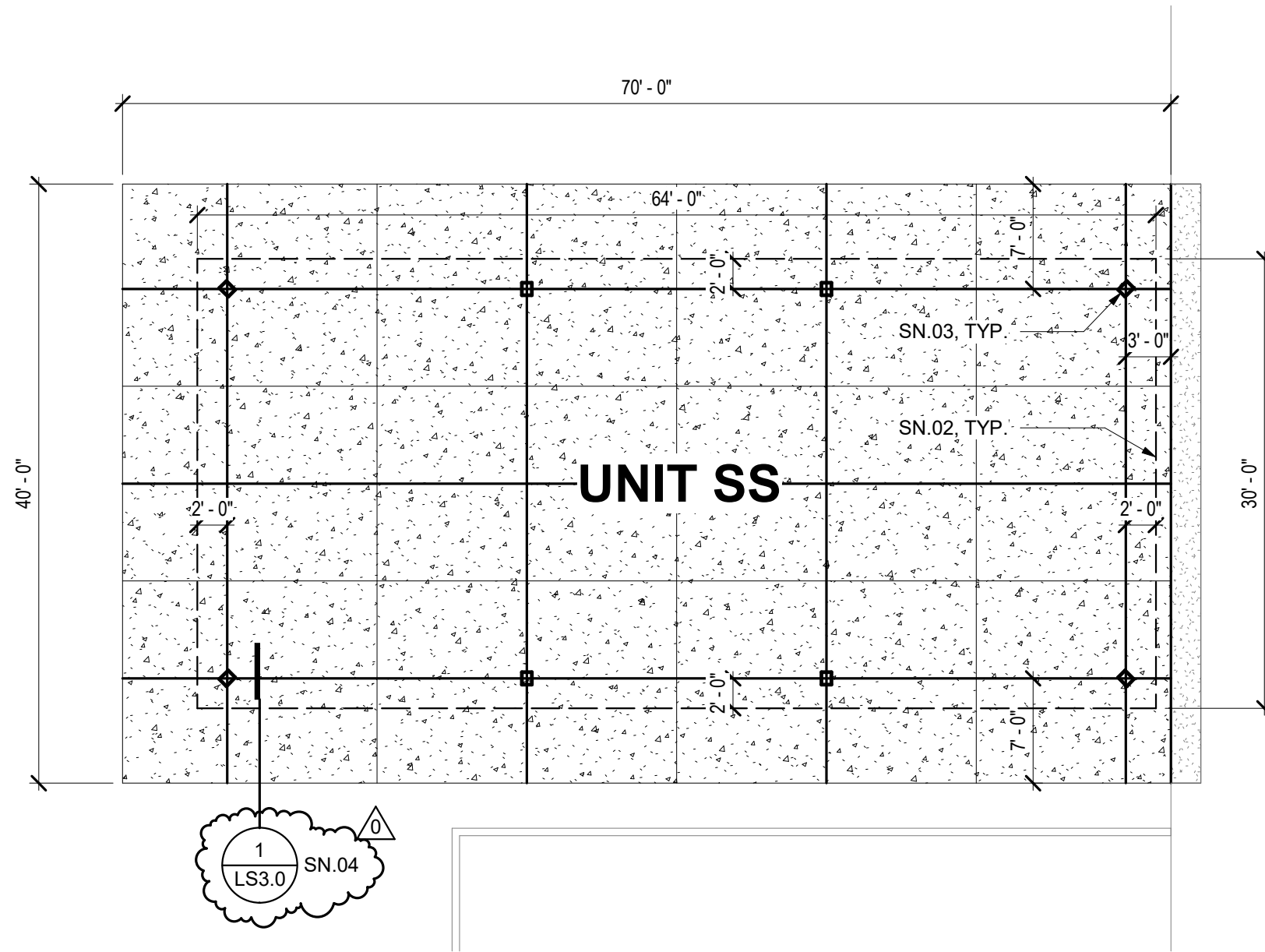

2 ENLARGED SITE PLAN - SHADE STRUCTURE
 1" = 10'-0"

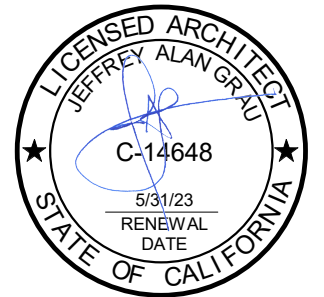

ADDENDUM ⁰

ALL FEATURES, NOTES AND DIMENSIONS NOT SPECIFICALLY SHOWN OR NOTED AS CHANGED SHALL REMAIN AS SHOWN ON PREVIOUSLY ISSUED DOCUMENTS.



ENLARGED PLAN	A1.1.1	DATE: 04/29/22
SHADE STRUCTURE AT JOHN BIDWELL ELEMENTARY SCHOOL SACRAMENTO CITY UNIFIED SCHOOL DISTRICT SACRAMENTO, CA DSA APP.02-119979		
PROJECT NO.: 21-1504.02	SHEET: AD0.02	

65TH AVENUE

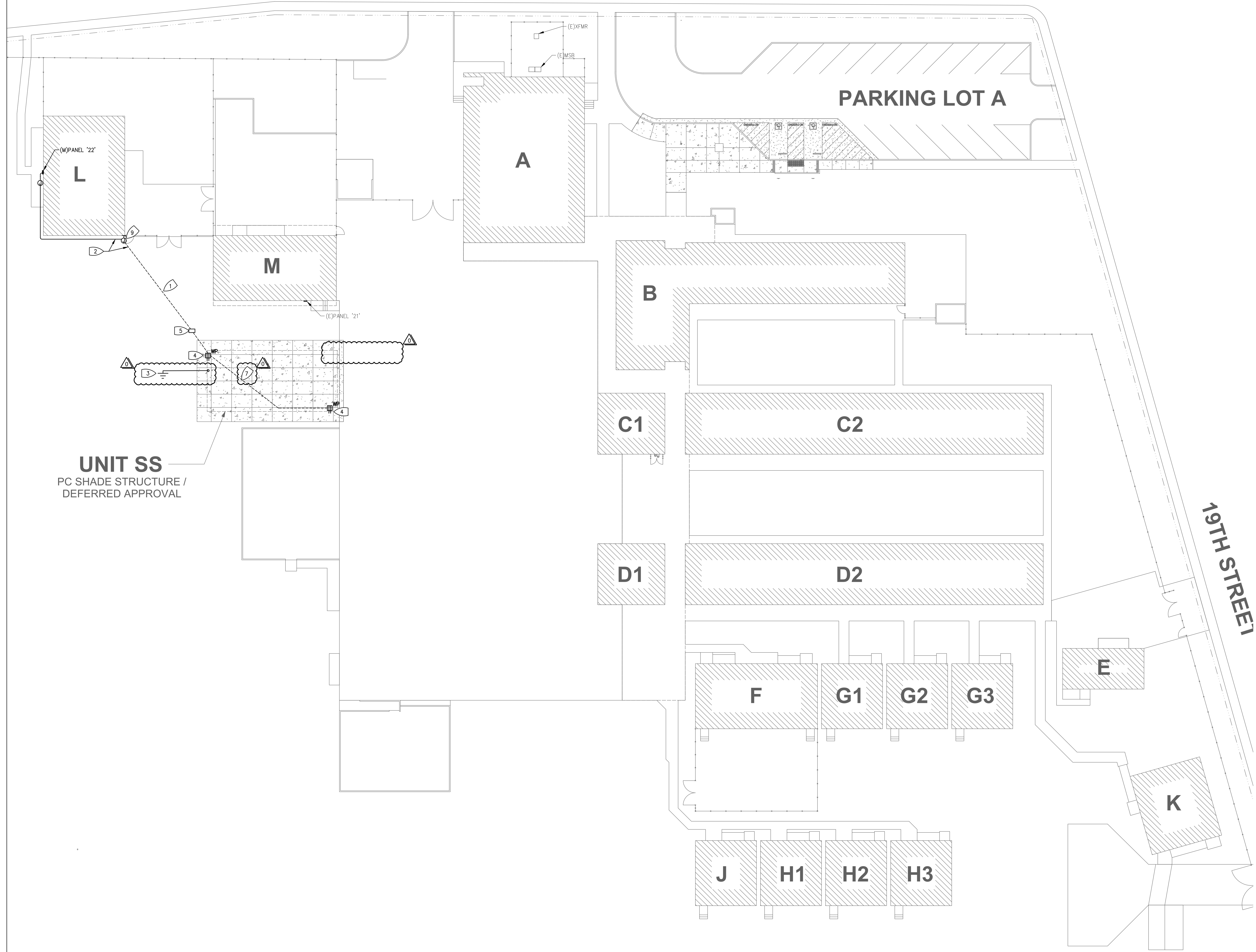

UNIT SS
PC SHADE STRUCTURE /
DEFERRED APPROVAL

PARKING LOT A

19TH STREET

SHEET NOTES:

1. ALL EXISTING EQUIPMENT, DEVICES, CONDUIT AND WIRING, ETC., SHOWN ON PLANS ARE BASED ON AVAILABLE EXISTING DRAWINGS AND LIMITED SITE SURVEYS, AND SHOWN FOR CLARITY ONLY.
2. SEE ONE LINE DIAGRAM AND PANEL SCHEDULE ON SHEET **E2.1** FOR REFERENCE.

KEYED NOTES:

1. PROVIDE TRENCH FOR 24" MINIMUM COVER. LOCATE AND PROTECT (S) UTILITIES, I.E. IRRIGATION, SEWER, DRAINAGE PIPES, ETC. PROVIDE SAND TO COVER CONDUIT TO SIX(6) INCHES, THEN ADD TRACER TAPE. COMPLETE BACKFILL TO GRADE, COMPACTING IN SIX(6)-INCH LIFTS. FINISH TO MATCH EXISTING. SEE DETAIL **3/E3.1**.
2. RUN CONDUIT HIGH ON WALL/OVERHANG TO WRAP AROUND BUILDING, DROP DOWN TO BELOW GRADE, AND TRENCH TO SHADE LOCATION, RUNNING CONDUIT TO INTERCEPT THE CHRISTY BOX ALONG THE WAY. PAINT EXPOSED CONDUIT TO MATCH (E) FINISH.
3. PROVIDE AT MINIMUM TWO(2) GROUND RIGS, ONE AT THE PULL BOX AND ONE NEAR THE CORNER POST OF THE SHADE STRUCTURE, EACH 5/8" BY TEN(10) FEET LONG, CU, AT LEAST TEN(10) FEET APART. BOND TO METAL OF SHADE STRUCTURE. SEE DETAILS **5/E3.1** AND **2/E3.1**.
4. LOCKABLE, WEATHERPROOF RECEPTACLE TO HAVE A TWO-GANG BACK BOX WITH 1" THREADED PORT(S). MOUNT RECEPTACLES 36" ABOVE GRADE UNLESS SPECIFIED OTHERWISE. SEE DETAIL **4/E3.1**.
5. PROVIDE CHRISTY B1324 PULL BOX WITHIN FIVE(5) FT OF SHADE STRUCTURE. CHRISTY BOX TO HAVE HOLD DOWN BOLTS AND BE LABELED FOR POWER. SEE DETAIL **2/E3.1**.
6. PROVIDE J-BOX HIGH ON WALL.
7. RUN CONDUIT BELOW SHADE STRUCTURE CONCRETE PAD.

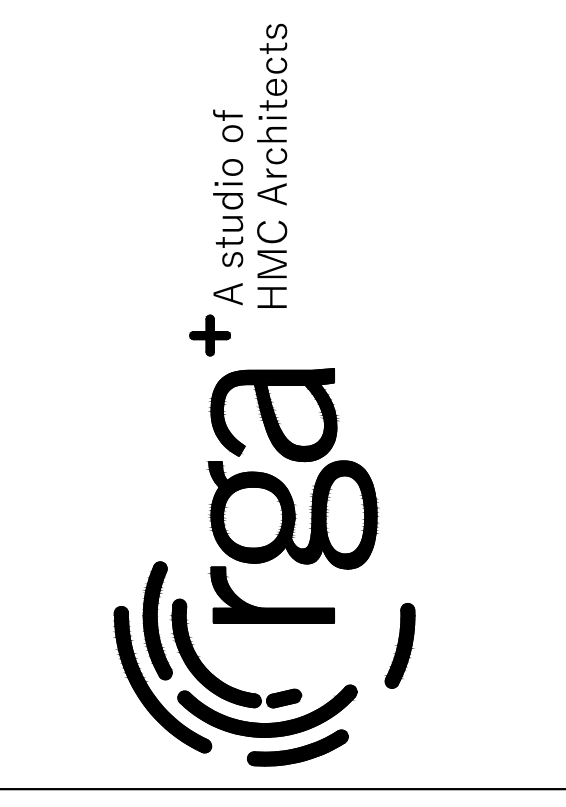

PETERS
engineering
7750 College Town Dr., ste.101
Sacramento, CA 95826
Tel (916) 447-2841
www.peterseng.com
Job no. 22.010
consulting mechanical and electrical engineers



PLOT DATE: 4/26/2022

**SHADE STRUCTURE AT JOHN BIDWELL
ELEMENTARY SCHOOL**

**SACRAMENTO CITY UNIFIED SCHOOL DISTRICT
SACRAMENTO, CA**

Revision	
ADDENDUM	4/29/22

Copyright © 2021 Rainforth Grau Architects. All rights reserved. Reproduction of these plans, either in whole or in part, including any form of copying and/or preparation of derivative works thereof, for any reason without prior written permission, is strictly prohibited.

**SITE PLAN -
ELECTRICAL**

PROJECT NO. 21-1504.02
DATE: 4/29/22
SHEET

E1.1

AD0.03

1 SITE PLAN - ELECTRICAL
SCALE: 1"=20'

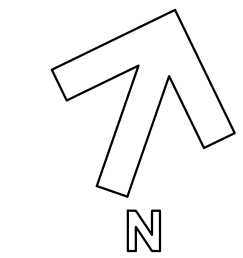

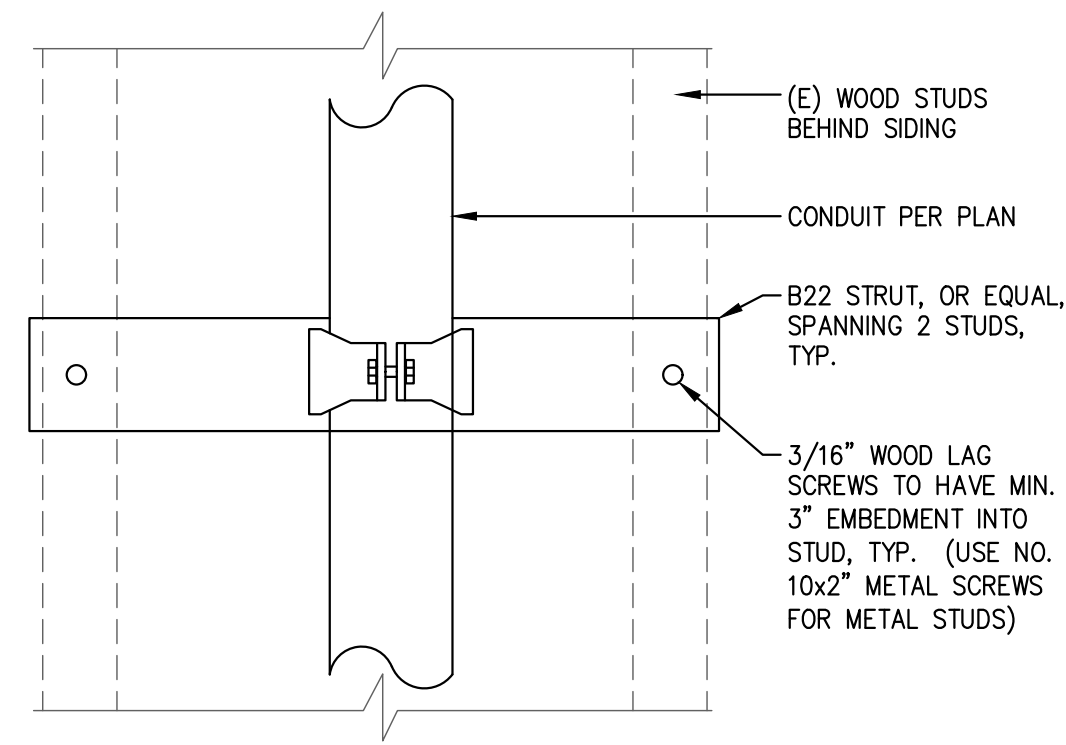

CONDUIT RUN PARALLEL TO STUDS

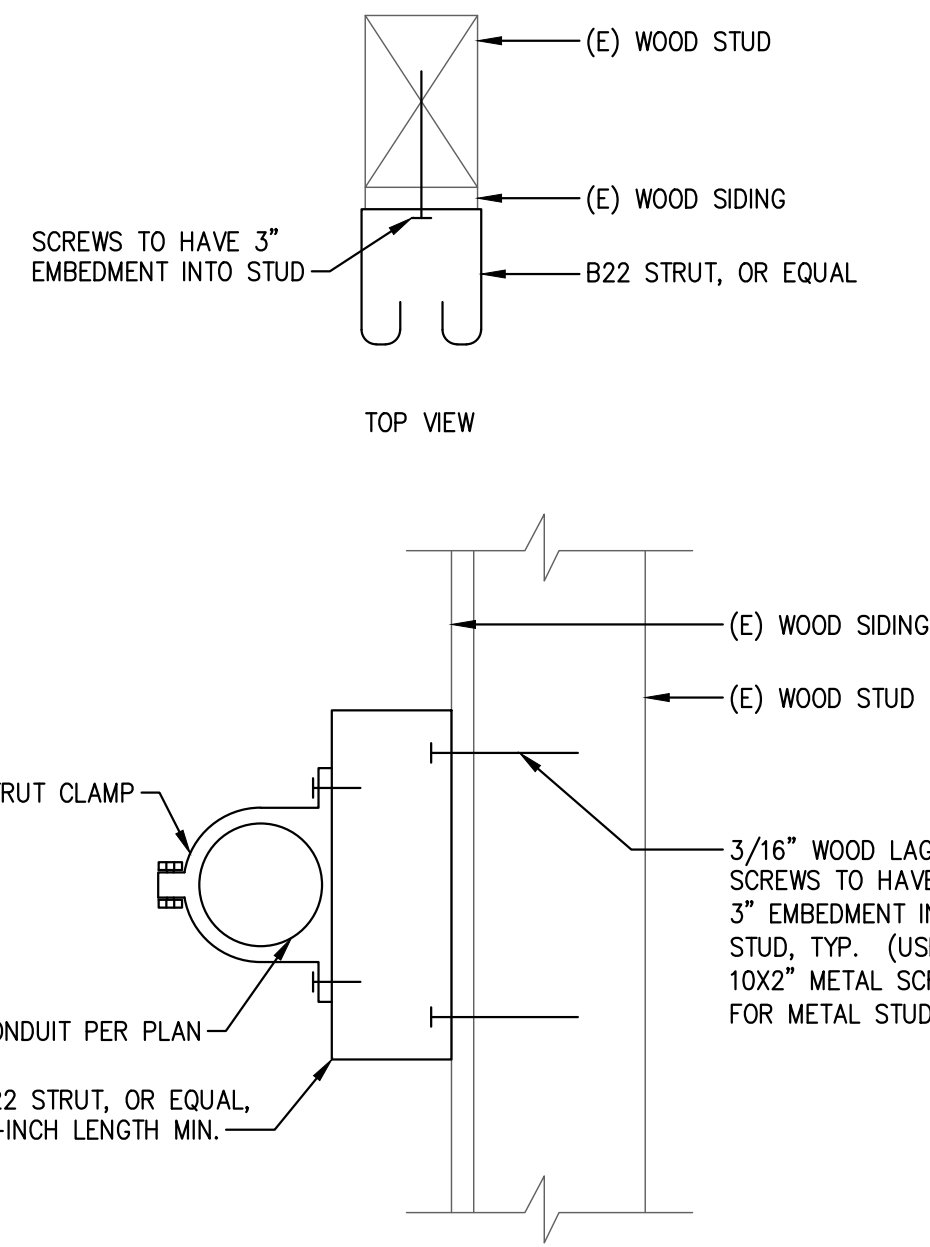

CONDUIT RUN PERPENDICULAR TO STUDS

- NOTES:
- CONDUIT SHALL BE SUPPORTED AT INTERVALS NOT EXCEEDING TEN(10) FEET AND NOT MORE THAN THREE(3) FEET FROM THE OUTLET AND AT ANY POINT WHERE IT CHANGES DIRECTION.
 - PERFORATED STRAP AND PLUMBER'S TAPE SHALL NOT BE PERMITTED.
 - MAXIMUM CONDUIT AND CONDUCTOR WEIGHT IS 1.83LBS PER LINEAR FOOT.

7 CONDUIT MOUNTING DETAIL - STUD WALLS

SCALE: NONE

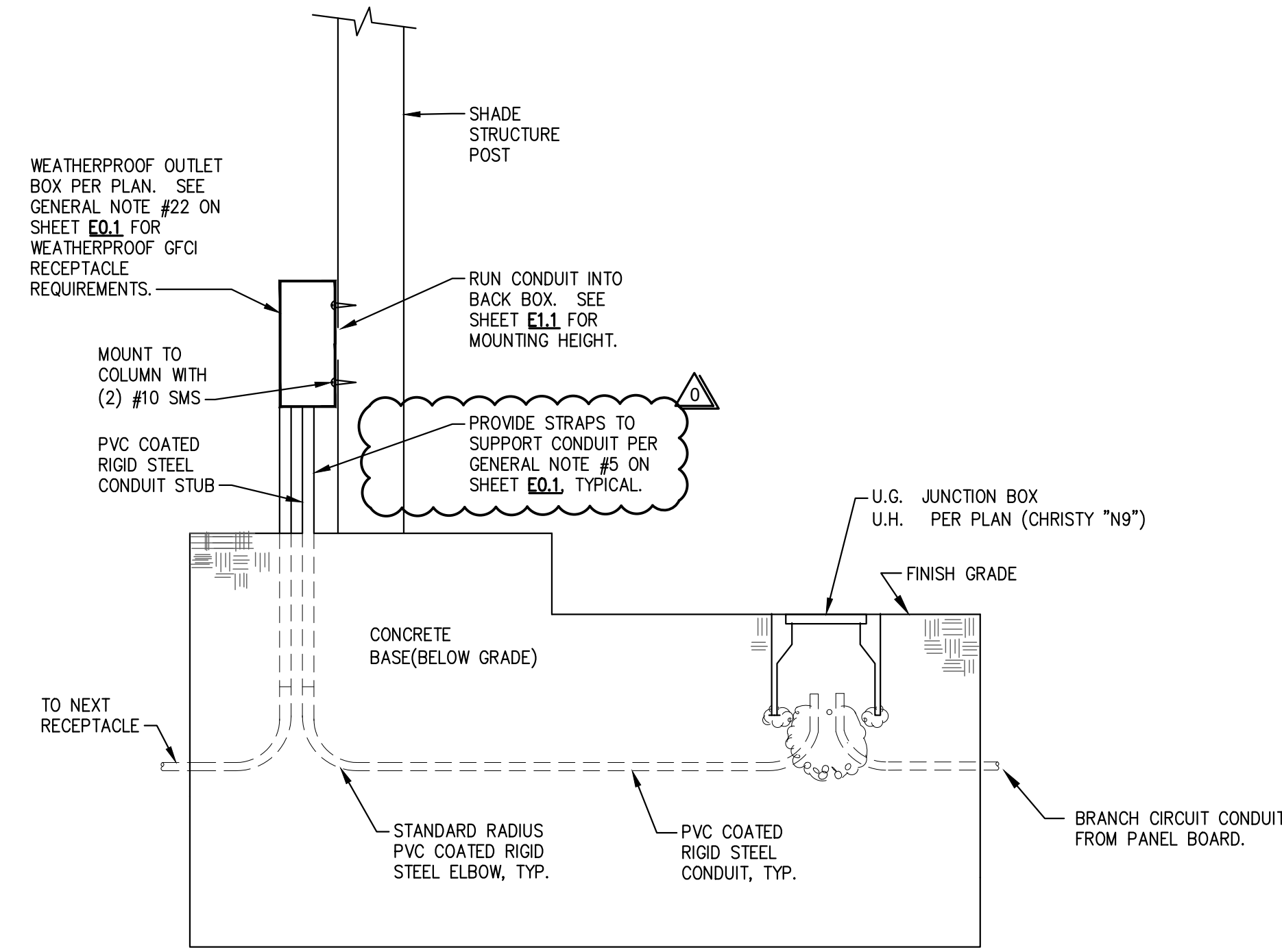

4 CONDUIT STUB IN POST DETAIL

SCALE: NONE

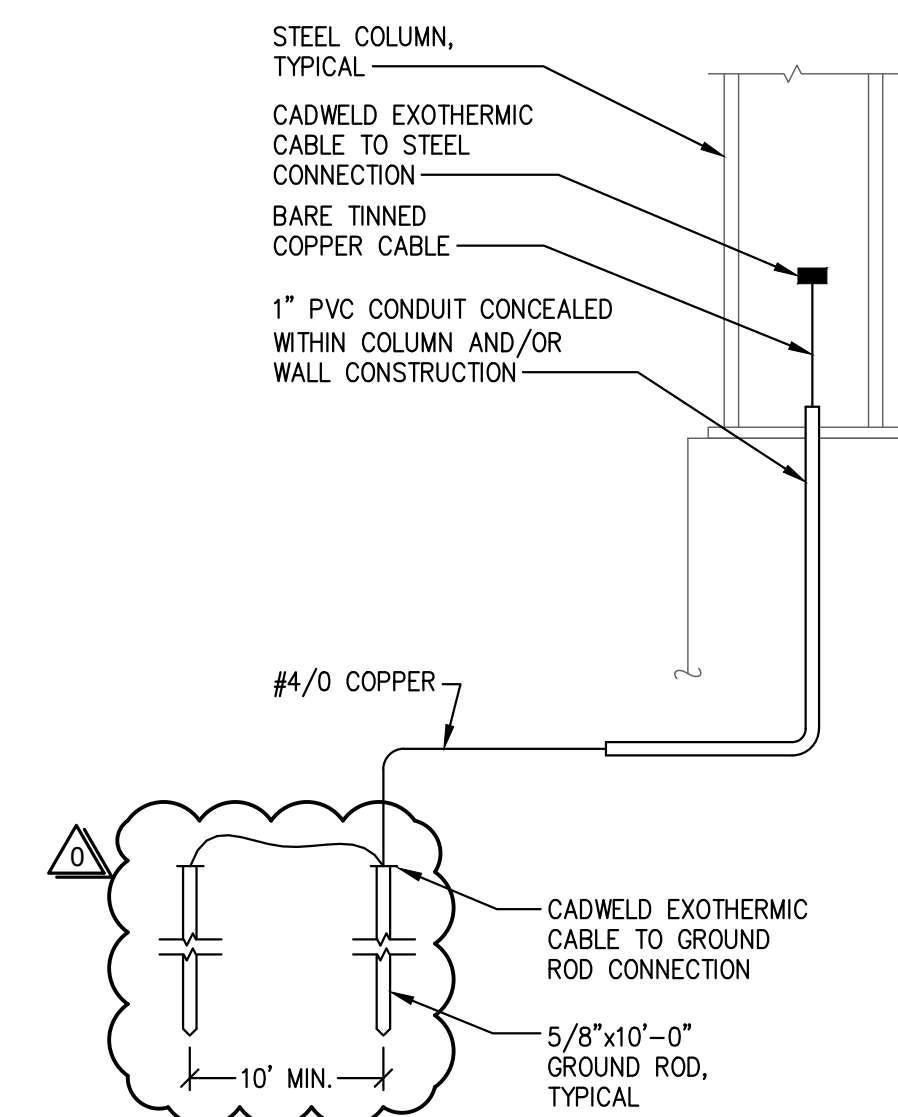

- NOTES:
- ALL GROUNDING CONNECTIONS SHALL BE IN CONFORMANCE WITH N.E.C. ARTICLE 250.
 - FOR ALL ADDITIONAL REQUIREMENTS REFER TO SPEC SECTIONS 26 05 10.

5 TYPICAL STEEL COLUMN & REBAR GROUNDING DETAIL

SCALE: NONE

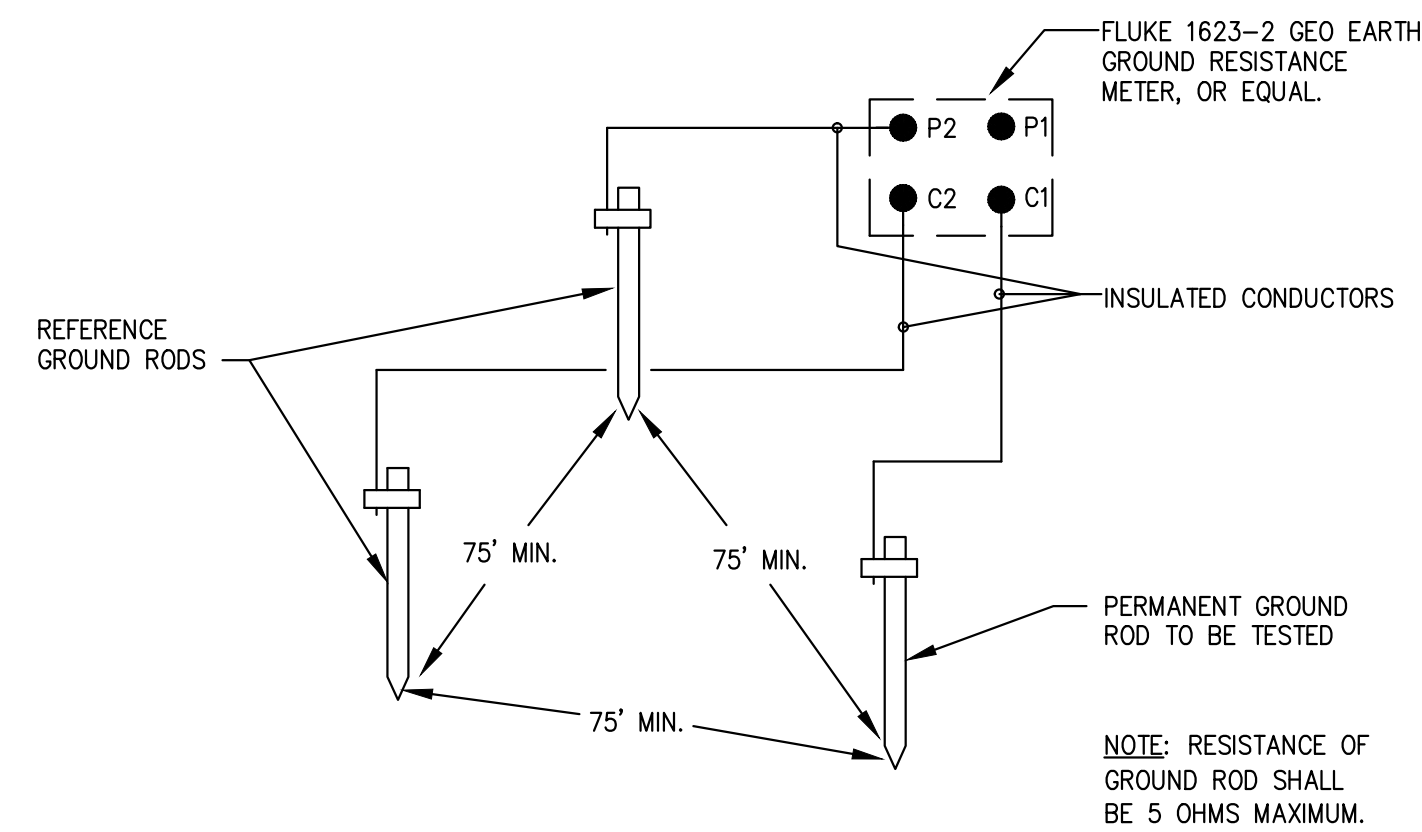

- FALL OF POTENTIAL TEST METHOD NOTES:
- POWER EQUIPMENT OR SYSTEMS WITH CAPACITY OF 500KVA OR LESS: 10 OHMS.
 - POWER EQUIPMENT OR SYSTEMS WITH CAPACITY OF 500 TO 1000KVA: 5 OHMS.
 - POWER EQUIPMENT OR SYSTEMS WITH CAPACITY GREATER THAN 1000KVA: 3 OHMS.
 - POWER DISTRIBUTION UNITS OR PANELBOARDS SERVING ELECTRONIC I.T. EQUIPMENT: 3 OHMS.
 - MAN-HOLE GROUNDS: 10 OHMS.
- FALL OF POTENTIAL 3-POINT TEST: GROUND RING, I.E. 10 BY 10 RING, 14' DIAGONAL LENGTH ISOLATION FROM UTILITY NEUTRAL PROBE Z IS DRIVEN A DISTANCE OF 10 TIMES DIAGONAL LENGTH OF THE GROUNDING ROD SYSTEM (ROD X). A SECOND PROBE (Y) IS PLACED IN LINE AT A DISTANCE FROM ROD X EQUAL TO THE DIAGONAL LENGTH OF THE GROUNDING SYSTEM.

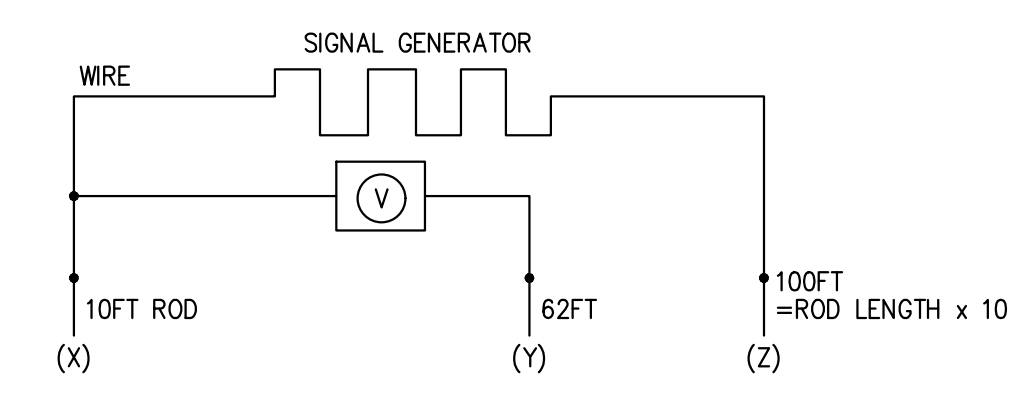

AT THIS POINT, A KNOWN CURRENT IS APPLIED ACROSS X & Z, WHILE THE RESULTING VOLTAGE IS MEASURED ACROSS X & Y. OHMS LAW APPLIED $R=V/I$. THEN (Y) MOVED TO 2 TIMES THE DIAGONAL LENGTH, THEN MOVE OUT TO 3 TIMES(3X), 4X, ... 9X THE DIAGONAL LENGTH TO COMPLETE THE 3 POINT TEST WITH A TOTAL OF NINE RESISTANCE MEASUREMENTS.

6 METHOD OF TESTING GROUND RODS DETAIL

SCALE: NONE

1 DETAIL REMOVED

SCALE: NONE

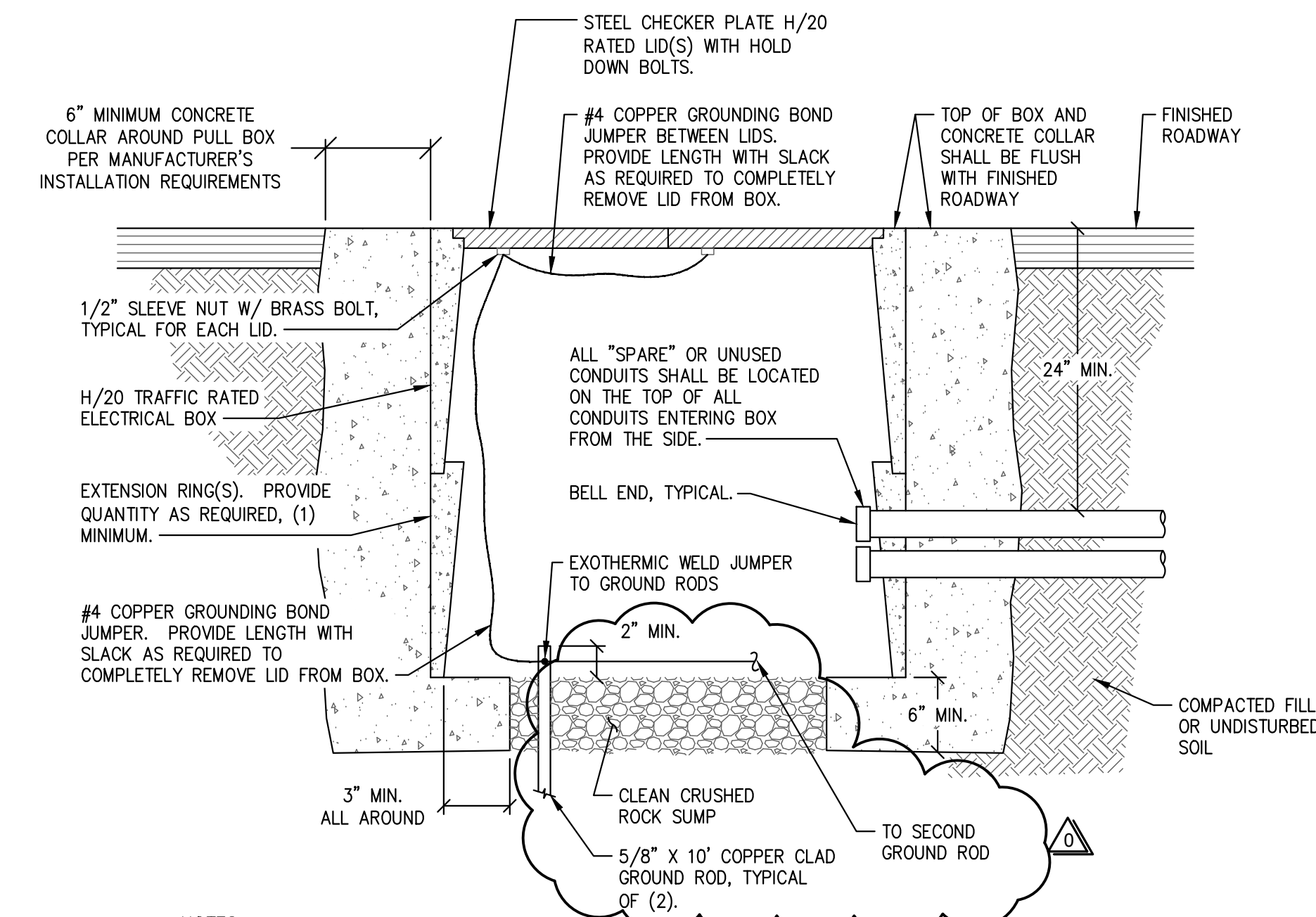

- NOTES:
- PROVIDE H/20 TRAFFIC RATED BOXES IN ALL LOCATIONS WITH VEHICLE TRAFFIC.
 - CONTRACTOR SHALL PROVIDE THE MANUFACTURER'S INSTALLATION INSTRUCTIONS FOR H/20 TRAFFIC RATING REQUIREMENTS AS PART OF THE SUBMITTALS.

2 TYPICAL H/20 TRAFFIC RATED PULL BOX

SCALE: NONE

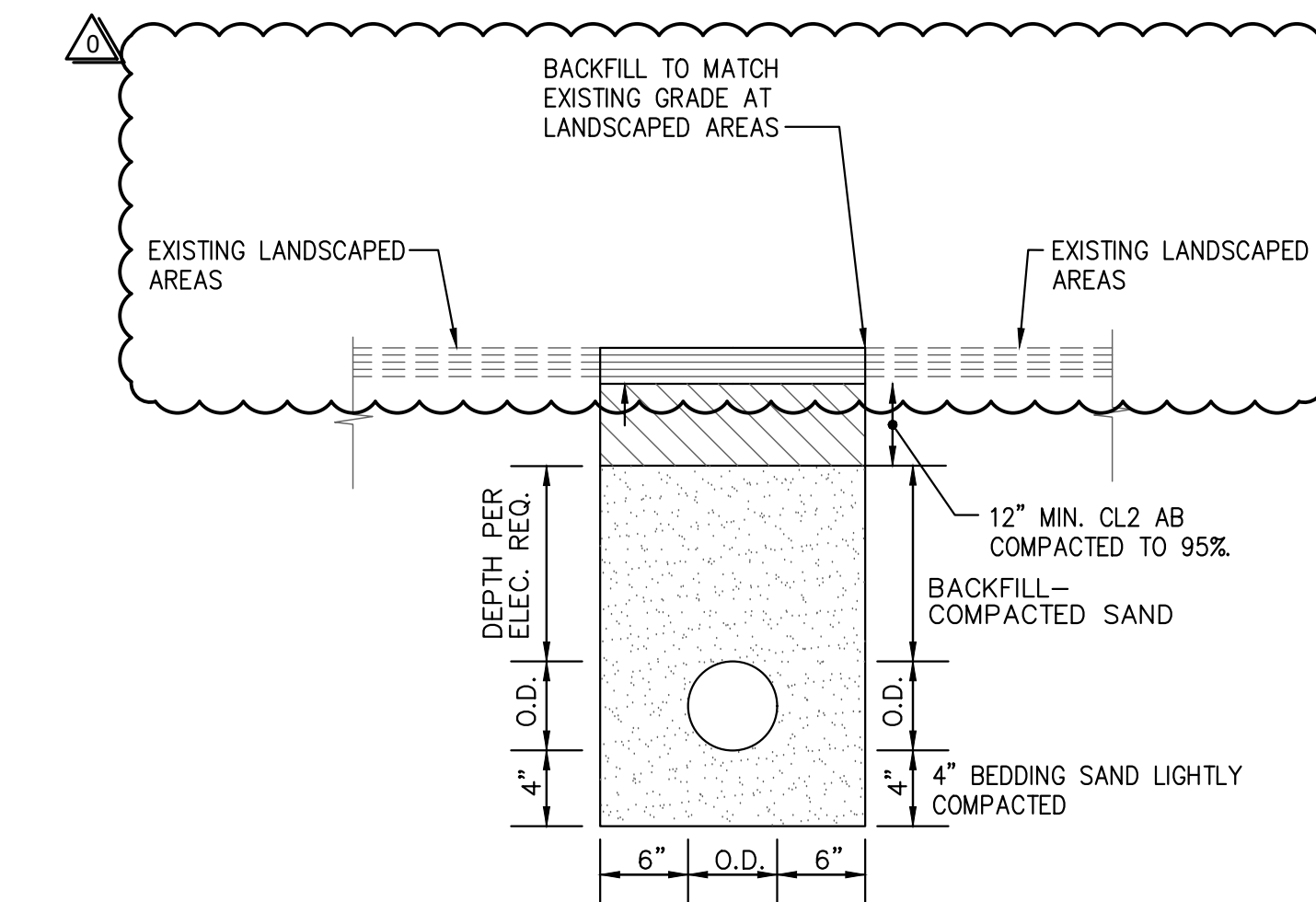

3 TYPICAL TRENCH DETAIL

SCALE: NONE

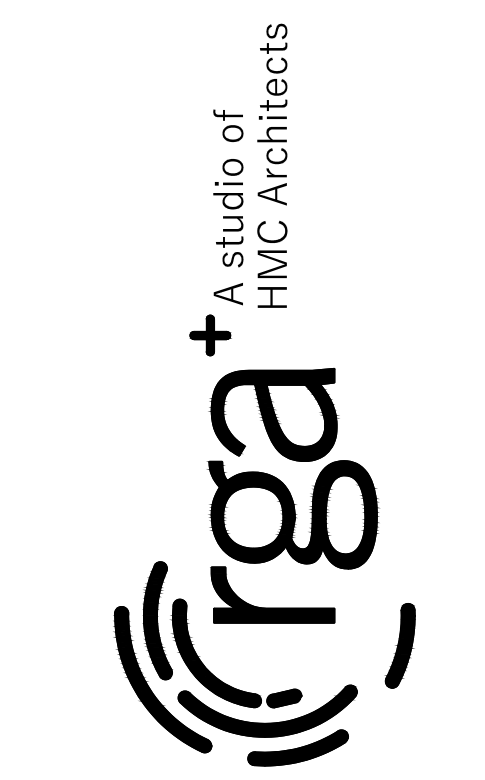

PETERS engineering
7750 College Town Dr. ste.101
Sacramento, CA 95826
Tel (916) 447-2841
www.peterseng.com
Job no. 22.010
consulting mechanical and electrical engineers

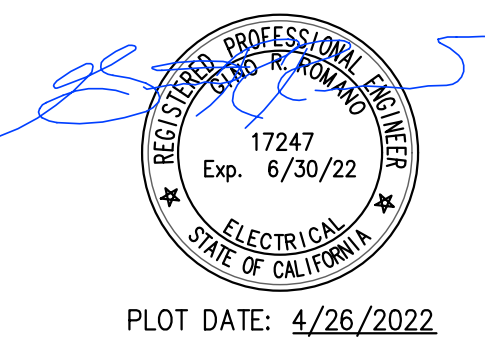

PLOT DATE: 4/26/2022

SHADE STRUCTURE AT JOHN BIDWELL ELEMENTARY SCHOOL
SACRAMENTO CITY UNIFIED SCHOOL DISTRICT
SACRAMENTO, CA

Revision	
ADDENDUM	4/29/22

Copyright © 2021 Rainforth Grau Architects. All rights reserved. Reproduction of these plans, either in whole or in part, including any form of copying and/or preparation of derivative works thereof, for any reason without prior written permission, is strictly prohibited.

DETAILS

PROJECT NO.	21-1504.02
DATE:	4/29/22
SHEET	E3.1

Statement of General Conformance

THE FOLLOWING DRAWINGS OR SHEETS LISTED ON THE COVER OR INDEX SHEET HAVE BEEN PREPARED BY OTHER DESIGN PROFESSIONALS OR CONSULTANTS WHO ARE LICENSED AND/OR AUTHORIZED TO PREPARE SUCH DRAWINGS IN THIS STATE. IT HAS BEEN EXAMINED BY ME FOR:

- 1) DESIGN INTENT AND APPEARS TO MEET THE APPROPRIATE REQUIREMENTS OF TITLE 24, CALIFORNIA CODE OF REGULATIONS AND THE PROJECT SPECIFICATIONS PREPARED BY ME, AND
- 2) COORDINATION WITH MY PLANS AND SPECIFICATIONS AND IS ACCEPTABLE FOR INCORPORATION INTO THE CONSTRUCTION OF THIS PROJECT.

THE STATEMENT OF GENERAL CONFORMANCE "SHALL NOT BE CONSTRUED AS RELIEVING ME OF MY RIGHTS, DUTIES, AND RESPONSIBILITIES UNDER SECTIONS 17302 AND 81138 OF THE EDUCATION CODE AND SECTIONS 4-336, 4-341, AND 4-344" OF TITLE 24, PART 1. (TITLE 24, PART 1, SECTION 4-317 (b))



SIGNATURE

4/21/22

DATE

ARCHITECT OR ENGINEER DESIGNATED TO BE IN GENERAL RESPONSIBLE CHARGE

Jeffrey Grau

PRINT NAME

C-14648

05/31/23

LICENSE NUMBER

EXPIRATION DATE

LIST COMPLETELY, ITEMS REVIEWED AND ACCEPTED:

PC SHADE STRUCTURE

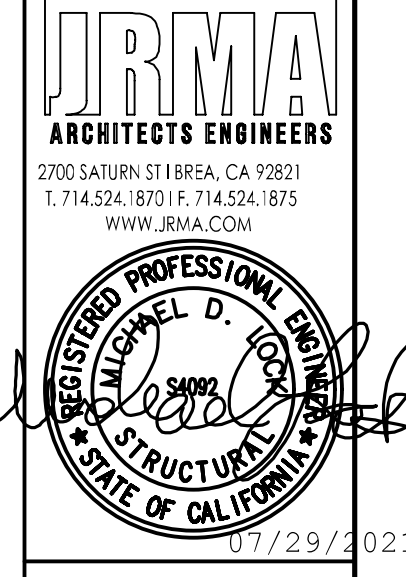
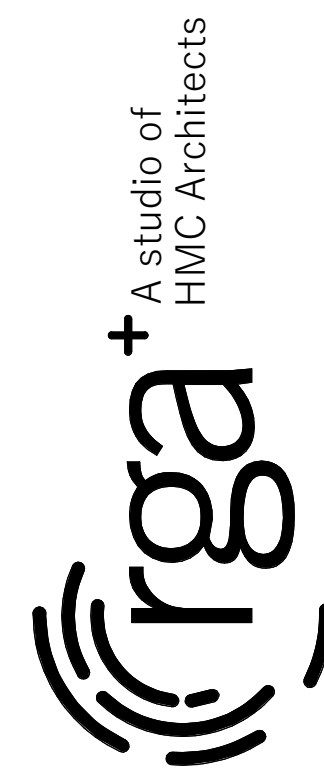

04/22/2021

DESIGN CRITERIA table with columns for DESCRIPTION and DESIGN VALUES. Includes sections for DEAD AND LIVE LOADS, WIND DESIGN, SEISMIC DESIGN, and FLOOD DESIGN.

GENERAL notes and specifications. Includes sections for GENERAL NOTES AND TYPICAL DETAILS, WELDING, BOLTING, FOUNDATIONS, and STRUCTURAL AND MISCELLANEOUS STEEL.

REINFORCING STEEL specifications and details. Includes sections for REINFORCING STEEL, WELDING, BOLTING, FOUNDATIONS, and CONCRETE.

ABBREVIATIONS table listing various construction terms and their corresponding symbols or units. Includes categories like ACI, ASTM, AWS, etc.

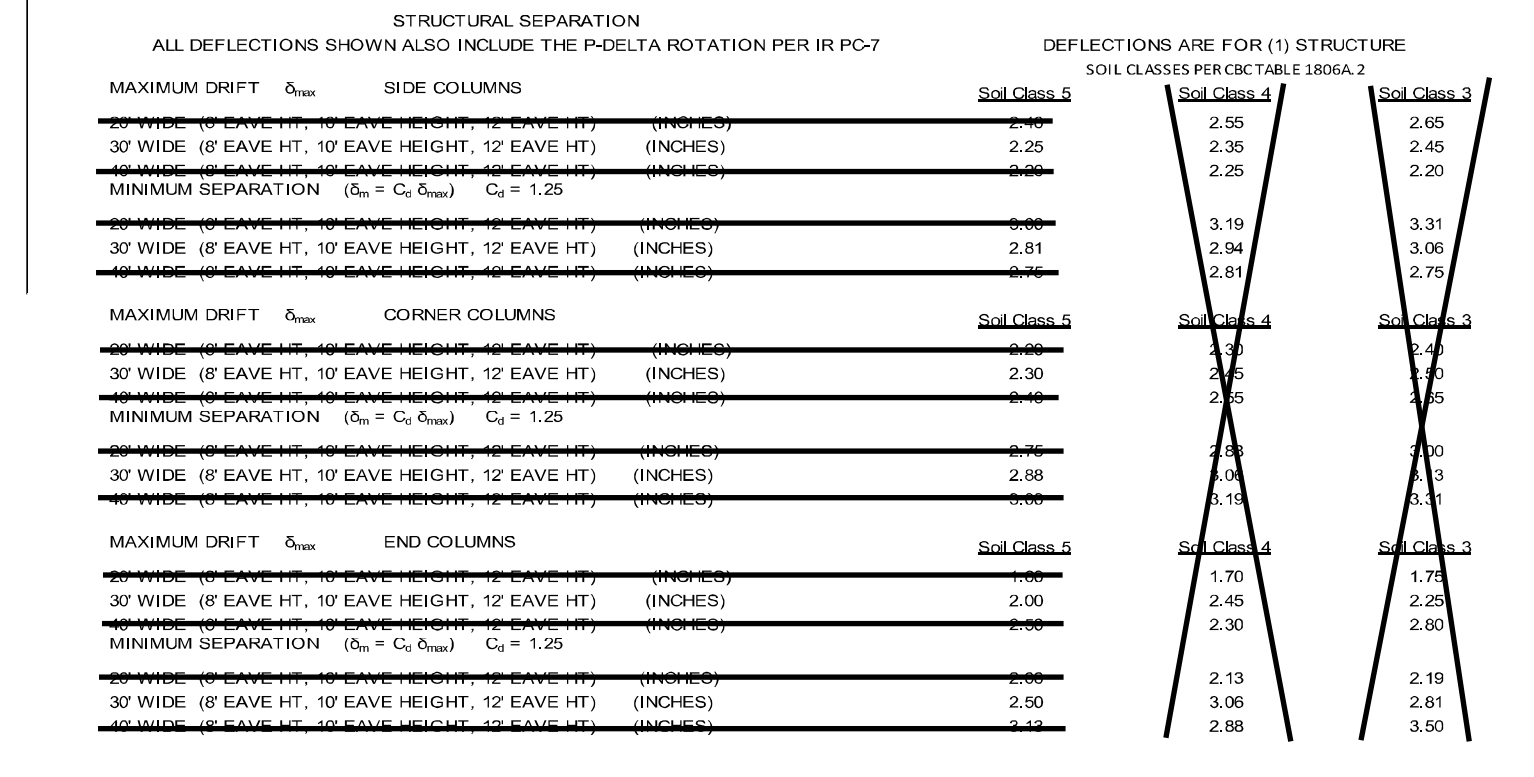

INSTRUCTIONS FOR ARCHITECTS SUBMITTING THESE PRE-CHECKED DRAWING TO DSA. Includes steps 1 through 10 for project identification and drawing preparation.

CONCRETE table with columns for STRENGTH FC (28 DAYS), W/C RATIO, W/C RATIO (AIR ENTRAINED), SLUMP (in), and UNIT WEIGHT (NORMAL WEIGHT). Includes notes on design parameters.

ARCHITECTURAL REQUIREMENTS table with columns for DESCRIPTION and DESIGN VALUES. Includes items like TYPE OF CONSTRUCTION, OCCUPANCY CLASSIFICATION, etc.

STEP 1: SELECT FRAME DIMENSIONS FOR YOUR PROJECT. Includes a table for FRAME DIMENSIONS with columns for FRAME WIDTH and FRAME LENGTH.

STEP 2: SELECT ROOF DECK FOR YOUR PROJECT. Includes a table for ROOF PANEL with columns for FRAME WIDTH and FRAME LENGTH.

STEP 3: IDENTIFY THE Ss REGION FOR YOUR PROJECT. Includes a table for Ss REGION with columns for Ss REGION, Ss REGIONS, and MAX DEAD LOAD.

STEP 4: IDENTIFY THE FOUNDATION REQUIREMENTS FOR YOUR PROJECT. Includes a table for FOUNDATION REQUIREMENTS with columns for SOIL CLASS 5 (BEARING) and SOIL CLASS 4 (BEARING).

STEP 5: SELECT APPLICABLE SHEET INDEX FOR YOUR PROJECT. Includes a table for SHEET INDEX with columns for BASE FRAME, ROOF PANEL TYPE, etc.

STEP 6: SELECT APPLICABLE SHEET INDEX FOR YOUR PROJECT. Includes a table for SHEET INDEX with columns for ROOF DECK, COLLATERAL, and TOTAL.

STEP 7: MISCELLANEOUS table with columns for CLEAR HEIGHT, ELECTRICAL CUTOUTS, and GUTTERS.

STEP 8: SHEET INDEX table with columns for BASE FRAME, ROOF PANEL TYPE, and GENERAL NOTES.

STEP 9: TOTAL ROOF DEAD LOAD table with columns for DESCRIPTION, DEAD LOAD, and EXAMPLES.

STEP 10: IDENTIFY PROJECT NAME AND SCHOOL DISTRICT. Includes a table for PROJECT NAME and SCHOOL DISTRICT.

CONSTRUCTION NOTES. Includes a list of notes regarding DSA certification, inspection requirements, and construction standards.

CONCRETE table with columns for STRENGTH FC (28 DAYS), W/C RATIO, W/C RATIO (AIR ENTRAINED), SLUMP (in), and UNIT WEIGHT (NORMAL WEIGHT).

STEP 1: SELECT FRAME DIMENSIONS FOR YOUR PROJECT. Includes a table for FRAME DIMENSIONS with columns for FRAME WIDTH and FRAME LENGTH.

STEP 2: SELECT ROOF DECK FOR YOUR PROJECT. Includes a table for ROOF PANEL with columns for FRAME WIDTH and FRAME LENGTH.

STEP 3: IDENTIFY THE Ss REGION FOR YOUR PROJECT. Includes a table for Ss REGION with columns for Ss REGION, Ss REGIONS, and MAX DEAD LOAD.

STEP 4: IDENTIFY THE FOUNDATION REQUIREMENTS FOR YOUR PROJECT. Includes a table for FOUNDATION REQUIREMENTS with columns for SOIL CLASS 5 (BEARING) and SOIL CLASS 4 (BEARING).

STEP 5: SELECT APPLICABLE SHEET INDEX FOR YOUR PROJECT. Includes a table for SHEET INDEX with columns for BASE FRAME, ROOF PANEL TYPE, etc.

STEP 6: SELECT APPLICABLE SHEET INDEX FOR YOUR PROJECT. Includes a table for SHEET INDEX with columns for ROOF DECK, COLLATERAL, and TOTAL.

DESIGN CRITERIA FOR 1730 65TH AVENUE, SACRAMENTO, CA 95822. Includes a table for DESIGN CRITERIA with columns for DESCRIPTION and DESIGN VALUES.

WIND DESIGN table with columns for BASIC WIND SPEED (3 SECOND GUST), Vw, RISK CATEGORY, and EXPOSURE CATEGORY.

SEISMIC DESIGN table with columns for SEISMIC SITE CLASS and D.

APPROVED APP: 04-2019-PC REVISED FOR SS [] PS [] ACS [] CG [] DATE: 08/06/2021

GENERAL INFO table with columns for DESCRIPTION and DESIGN VALUES. Includes items like WIND DESIGN, RISK CATEGORY, etc.

SEISMIC DESIGN table with columns for SEISMIC SITE CLASS and D.

DESIGN CRITERIA FOR 1730 65TH AVENUE, SACRAMENTO, CA 95822. Includes a table for DESIGN CRITERIA with columns for DESCRIPTION and DESIGN VALUES.

WIND DESIGN table with columns for BASIC WIND SPEED (3 SECOND GUST), Vw, RISK CATEGORY, and EXPOSURE CATEGORY.

SEISMIC DESIGN table with columns for SEISMIC SITE CLASS and D.

PRE-CHECK (PC) DOCUMENT Code: 2019 CBC A separate project application for construction is required.

SHADE STRUCTURE AT JOHN BIDWELL ELEMENTARY SCHOOL

SACRAMENTO CITY UNIFIED SCHOOL DISTRICT SACRAMENTO, CA

Revision

GENERAL INFO

1455 LINCOLN AVE HOLLAND MI, 49423 616.396.0919 800.748.0985 616.396.0944 FX

PRE-CHECK (PC) DOCUMENT Code: 2019 CBC A separate project application for construction is required.

PROJECT NO. 21-1504.02 DATE: 4/7/22 SHEET LS1.0 AD0.06

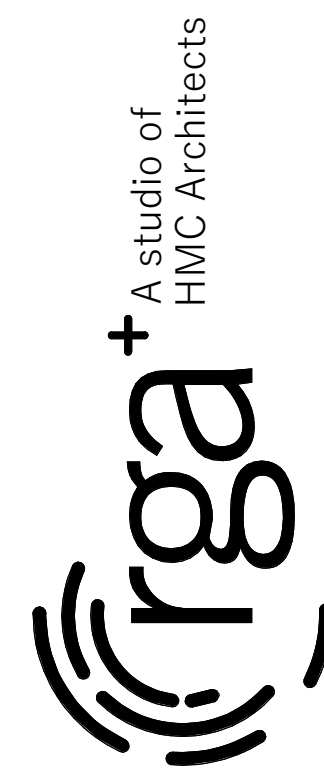

ICON STD RH/DSA-PC
DRAWN BY ANGEL
DATE 4/2/2021
REV
REV DATE



APPROVED
DIR. OF THE STATE ARCHITECT
APP: 04-120019-PC
REVIEWED FOR
SS □ CS □ ACS □ CG □
DATE: 08/06/2021

SHADE STRUCTURE AT JOHN BIDWELL
ELEMENTARY SCHOOL
SACRAMENTO CITY UNIFIED SCHOOL DISTRICT
SACRAMENTO, CA

DSA 103

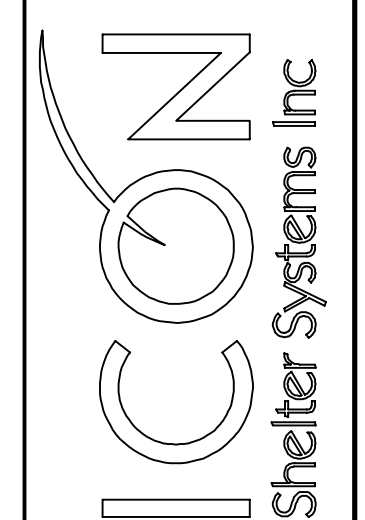

1455 LINCOLN AVE
HOLLAND MI, 49423
616.396.0919
800.748.0985
616.396.0944 FX

LS1.1

PRE-CHECK (PC) DOCUMENT
Code: 2019 CBC
A separate project application for construction is required.

PRINTED ON:

PROJECT NO. 21-1504.02
DATE: 4/7/22
SHEET

LS1.1
AD0.07

DSA 103-19: LISTING OF STRUCTURAL TESTS & SPECIAL INSPECTIONS, 2019 CBC
Application Number: 04-00000
DSA File Number: 2021-07-14 05:50:33
School Name: ICON Shelter Systems
School District: PC Submittal
Date Created: 2021-07-14 05:50:33
2019 CBC
IMPORTANT: This form is only a summary list of structural tests and some of the special inspections required for the project.
KEY TO COLUMNS
1. TYPE
2. SOIL COMPACTION AND FILL

DSA 103-19: LISTING OF STRUCTURAL TESTS & SPECIAL INSPECTIONS (SOILS), 2019 CBC
Application Number: 04-00000
DSA File Number: 2021-07-14 05:50:33
School Name: ICON Shelter Systems
School District: PC Submittal
Date Created: 2021-07-14 05:50:33
Geotechnical Reports: Project is a geotechnical report, or CDs indicate soils special inspection is required by GE
1. GENERAL
2. SOIL COMPACTION AND FILL

DSA 103-19: LISTING OF STRUCTURAL TESTS & SPECIAL INSPECTIONS (SOILS), 2019 CBC
Application Number: 04-00000
DSA File Number: 2021-07-14 05:50:33
School Name: ICON Shelter Systems
School District: PC Submittal
Date Created: 2021-07-14 05:50:33
5. RETAINING WALLS
6. OTHER SOIL

DSA 103-19: LISTING OF STRUCTURAL TESTS & SPECIAL INSPECTIONS (SOILS), 2019 CBC
Application Number: 04-00000
DSA File Number: 2021-07-14 05:50:33
School Name: ICON Shelter Systems
School District: PC Submittal
Date Created: 2021-07-14 05:50:33
5. RETAINING WALLS
6. OTHER SOIL

DSA 103-19: LISTING OF STRUCTURAL TESTS & SPECIAL INSPECTIONS (Concrete), 2019 CBC
Application Number: 04-00000
DSA File Number: 2021-07-14 05:50:33
School Name: ICON Shelter Systems
School District: PC Submittal
Date Created: 2021-07-14 05:50:33
7. CAST-IN-PLACE CONCRETE
Inspection

DSA 103-19: LISTING OF STRUCTURAL TESTS & SPECIAL INSPECTIONS (Concrete), 2019 CBC
Application Number: 04-00000
DSA File Number: 2021-07-14 05:50:33
School Name: ICON Shelter Systems
School District: PC Submittal
Date Created: 2021-07-14 05:50:33
17. STRUCTURAL STEEL, COLD-FORMED STEEL AND ALUMINUM USED FOR STRUCTURAL PURPOSE
Inspection

DSA 103-19: LISTING OF STRUCTURAL TESTS & SPECIAL INSPECTIONS (Concrete), 2019 CBC
Application Number: 04-00000
DSA File Number: 2021-07-14 05:50:33
School Name: ICON Shelter Systems
School District: PC Submittal
Date Created: 2021-07-14 05:50:33
18. WELDS
Inspection

DSA 103-19: LISTING OF STRUCTURAL TESTS & SPECIAL INSPECTIONS (Concrete), 2019 CBC
Application Number: 04-00000
DSA File Number: 2021-07-14 05:50:33
School Name: ICON Shelter Systems
School District: PC Submittal
Date Created: 2021-07-14 05:50:33
19. SHOP WELDING
23. ANCHOR BOLTS AND ANCHOR RODS

DSA 103-19: LISTING OF STRUCTURAL TESTS & SPECIAL INSPECTIONS (Steel and Aluminum), 2019 CBC
Application Number: 04-00000
DSA File Number: 2021-07-14 05:50:33
School Name: ICON Shelter Systems
School District: PC Submittal
Date Created: 2021-07-14 05:50:33
23. ANCHOR BOLTS AND ANCHOR RODS

DSA 103-19: LISTING OF STRUCTURAL TESTS & SPECIAL INSPECTIONS (SIGNATURE), 2019 CBC
Application Number: 04-00000
DSA File Number: 2021-07-14 05:50:33
School Name: ICON Shelter Systems
School District: PC Submittal
Date Created: 2021-07-14 05:50:33
Name of Architect or Engineer in general compliance with the Code
Name of Structural Engineer (Other structural design has been approved)

DSA 103-19: LIST OF REQUIRED VERIFIED REPORTS, CBC 2019
Application Number: 04-00000
DSA File Number: 2021-07-14 05:50:33
School Name: ICON Shelter Systems
School District: PC Submittal
Date Created: 2021-07-14 05:50:33
1. Soils Testing and Inspection: Geotechnical Verified Report Form DSA 293
2. Structural Testing and Inspection: Laboratory Verified Report Form DSA 291
3. Shop Welding Inspection: Laboratory Verified Report Form DSA 291, or, for independently contracting SI, Special Inspection Verified Report Form DSA 292
4. High-Strength Bolt Installation Inspection: Laboratory Verified Report Form DSA 291, or, for independently contracting SI, Special Inspection Verified Report Form DSA 292

FOR ALL TESTING AND INSPECTION ITEMS SEE THE DSA APPROVED 103 FOR THIS PROJECT.

DSA STAMP

DSA 103-19: LISTING OF STRUCTURAL TESTS & SPECIAL INSPECTIONS (Steel and Aluminum), 2019 CBC
Application Number: 04-00000
DSA File Number: 2021-07-14 05:50:33
School Name: ICON Shelter Systems
School District: PC Submittal
Date Created: 2021-07-14 05:50:33
23. ANCHOR BOLTS AND ANCHOR RODS

DSA 103-19: LISTING OF STRUCTURAL TESTS & SPECIAL INSPECTIONS (SIGNATURE), 2019 CBC
Application Number: 04-00000
DSA File Number: 2021-07-14 05:50:33
School Name: ICON Shelter Systems
School District: PC Submittal
Date Created: 2021-07-14 05:50:33
Name of Architect or Engineer in general compliance with the Code
Name of Structural Engineer (Other structural design has been approved)

DSA 103-19: LIST OF REQUIRED VERIFIED REPORTS, CBC 2019
Application Number: 04-00000
DSA File Number: 2021-07-14 05:50:33
School Name: ICON Shelter Systems
School District: PC Submittal
Date Created: 2021-07-14 05:50:33
1. Soils Testing and Inspection: Geotechnical Verified Report Form DSA 293
2. Structural Testing and Inspection: Laboratory Verified Report Form DSA 291
3. Shop Welding Inspection: Laboratory Verified Report Form DSA 291, or, for independently contracting SI, Special Inspection Verified Report Form DSA 292
4. High-Strength Bolt Installation Inspection: Laboratory Verified Report Form DSA 291, or, for independently contracting SI, Special Inspection Verified Report Form DSA 292

PRE-CHECK (PC) DOCUMENT
Code: 2019 CBC
A separate project application for construction is required.

PRINTED ON:

PROJECT NO. 21-1504.02
DATE: 4/7/22
SHEET

LS1.1
AD0.07

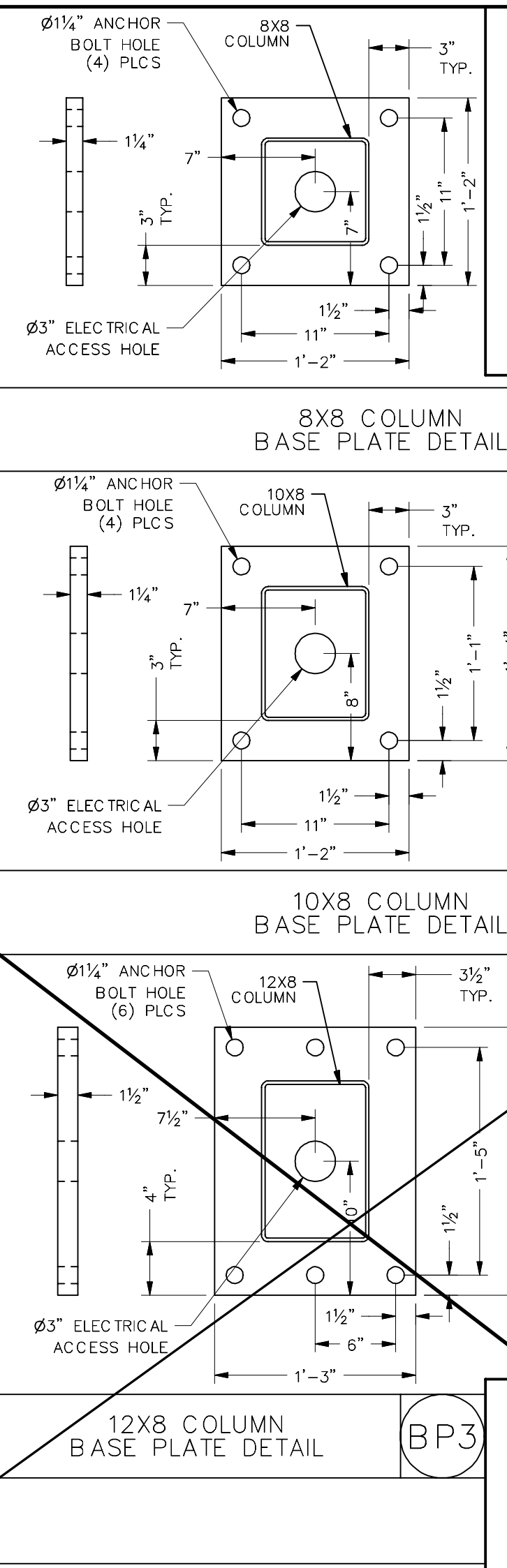
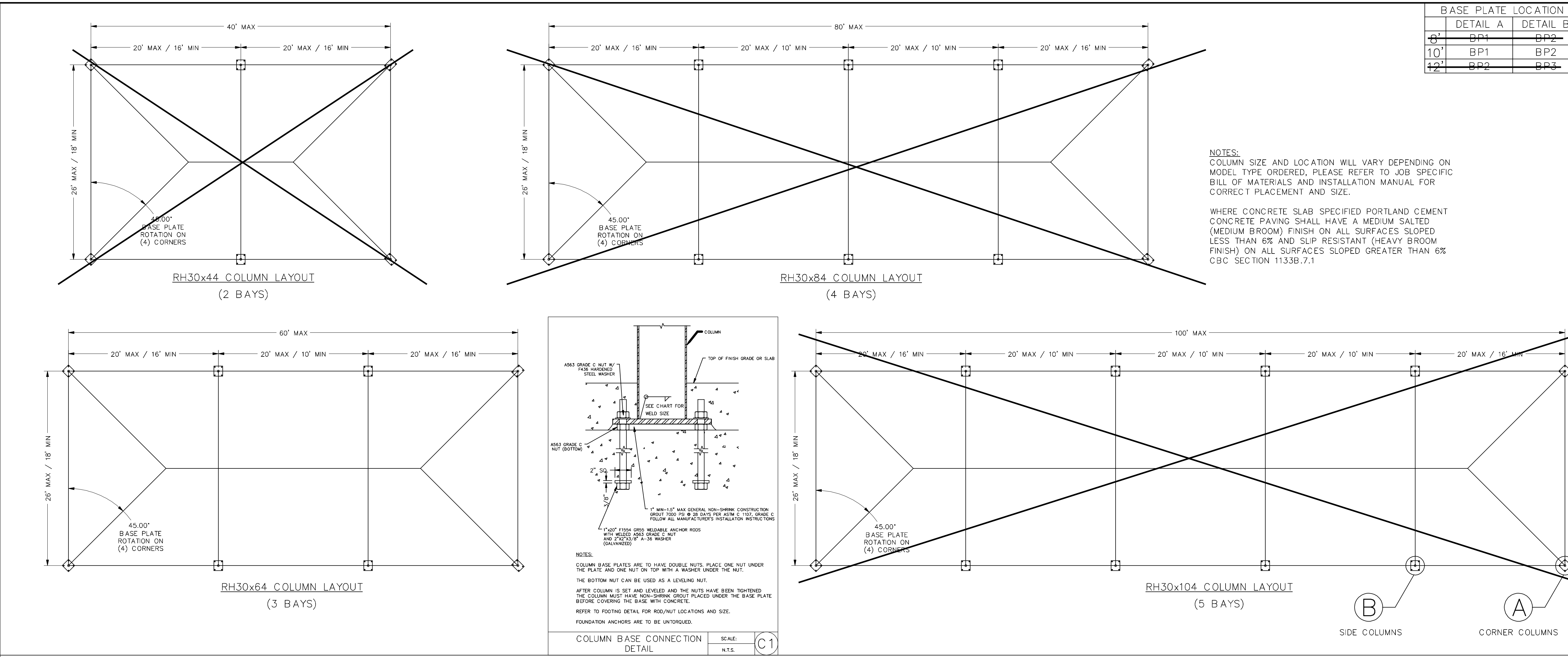

ICON STD 84/05A-PC
DRAWN BY ANGEL
DATE 4/2/2021
REV
REV DATE

JRMA ARCHITECTS ENGINEERS
2700 SUTHER ST BRCA, CA 95821
1714 25th ST #117, TULSA, OK 74104
WWW.JRMA.COM

PROFESSIONAL SEAL
JAMES R. MANNING
REGISTERED PROFESSIONAL ENGINEER
STRUCTURAL
STATE OF CALIFORNIA
No. 45897
Exp. 12/29/2021

APPROVED
DIV. OF THE STATE ARCHITECT
APP: 04-20013-PC
REVISED FOR
SS FLS ACS CG
DATE: 08/06/2021

RH30 - PIER

8' height - Corner Columns				8' height - Side Columns				10' height - Corner Columns				10' height - Side Columns							
Soil Class	Depth (in)	Rebar Qty	Rebar Size	Soil Class	Depth (in)	Rebar Qty	Rebar Size	Soil Class	Depth (in)	Rebar Qty	Rebar Size	Soil Class	Depth (in)	Rebar Qty	Rebar Size				
Soil Class 3 - 1500 psf Bearing	24	114	6	6	Soil Class 4 - 2000 psf Bearing	24	98	6	6	Soil Class 3 - 3000 psf Bearing	24	88	6	6	Soil Class 3 - 3000 psf Bearing	30	118	6	6
Soil Class 5 - 1500 psf Bearing	36	144	12	6	Soil Class 4 - 2000 psf Bearing	30	132	6	6	Soil Class 3 - 3000 psf Bearing	30	118	6	6	Soil Class 3 - 3000 psf Bearing	30	118	6	6
Soil Class 5 - 1500 psf Bearing	36	136	12	6	Soil Class 4 - 2000 psf Bearing	30	124	8	6	Soil Class 3 - 3000 psf Bearing	30	112	8	6	Soil Class 3 - 3000 psf Bearing	30	112	8	6
Soil Class 5 - 1500 psf Bearing	36	132	8	6	Soil Class 4 - 2000 psf Bearing	30	112	8	6	Soil Class 3 - 3000 psf Bearing	30	102	8	6	Soil Class 3 - 3000 psf Bearing	30	102	8	6
Soil Class 5 - 1500 psf Bearing	36	140	12	6	Soil Class 4 - 2000 psf Bearing	36	120	12	6	Soil Class 3 - 3000 psf Bearing	36	108	12	6	Soil Class 3 - 3000 psf Bearing	36	108	12	6

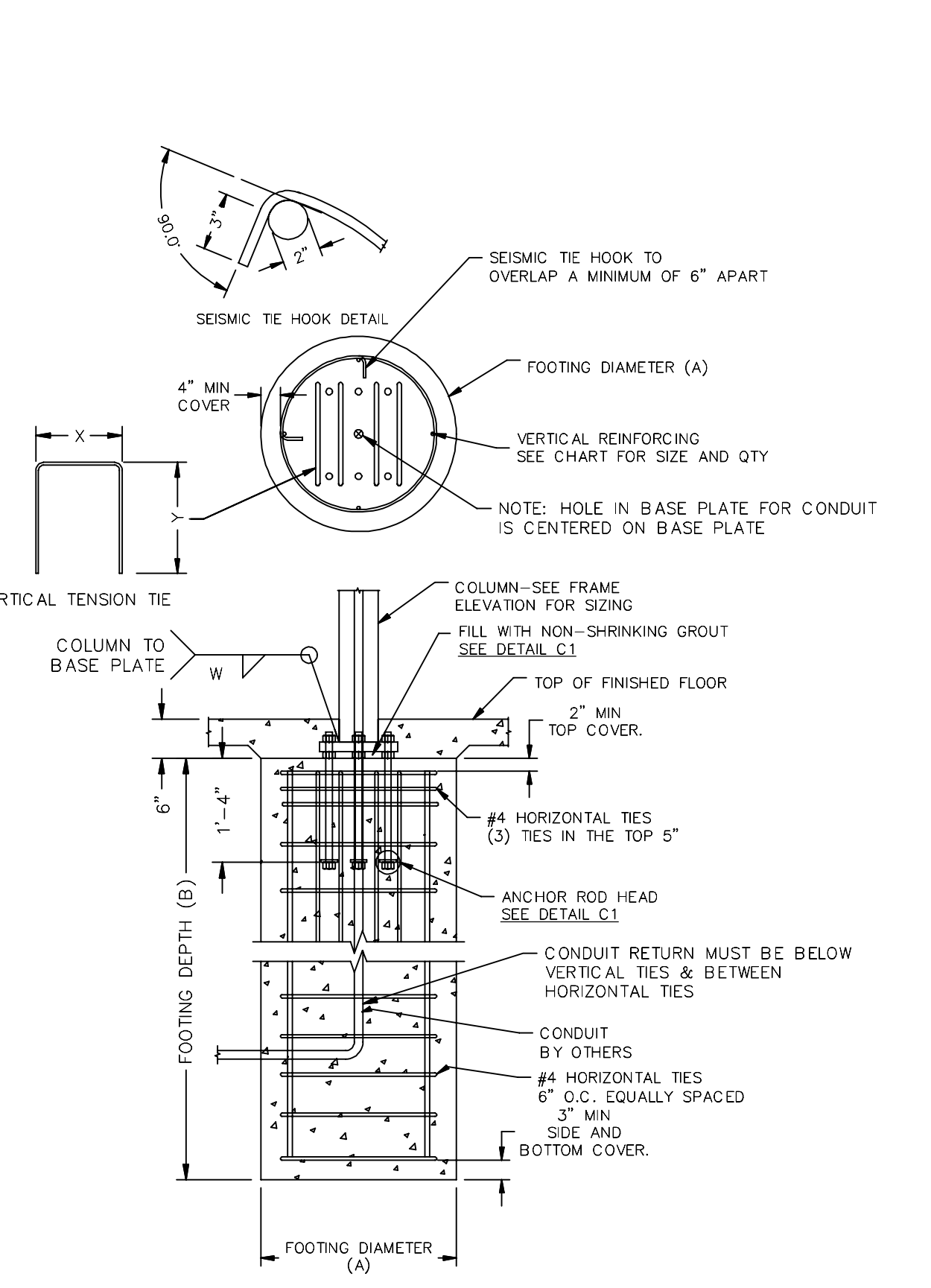

RH30 - SPREAD

8' height - Corner Columns				8' height - Side Columns				10' height - Corner Columns				10' height - Side Columns							
Soil Class	Depth (in)	Rebar Qty	Rebar Size	Soil Class	Depth (in)	Rebar Qty	Rebar Size	Soil Class	Depth (in)	Rebar Qty	Rebar Size	Soil Class	Depth (in)	Rebar Qty	Rebar Size				
Soil Class 5 - 1500 psf Bearing	60	30	4	6	Soil Class 4 - 2000 psf Bearing	56	30	4	6	Soil Class 3 - 3000 psf Bearing	54	30	4	6	Soil Class 3 - 3000 psf Bearing	54	30	4	6
Soil Class 5 - 1500 psf Bearing	80	30	5	6	Soil Class 4 - 2000 psf Bearing	72	30	5	6	Soil Class 3 - 3000 psf Bearing	68	30	5	6	Soil Class 3 - 3000 psf Bearing	68	30	5	6
Soil Class 5 - 1500 psf Bearing	66	30	5	6	Soil Class 4 - 2000 psf Bearing	60	30	4	6	Soil Class 3 - 3000 psf Bearing	57	30	4	6	Soil Class 3 - 3000 psf Bearing	57	30	4	6
Soil Class 5 - 1500 psf Bearing	81	30	5	6	Soil Class 4 - 2000 psf Bearing	72	30	5	6	Soil Class 3 - 3000 psf Bearing	69	30	5	6	Soil Class 3 - 3000 psf Bearing	69	30	5	6
Soil Class 5 - 1500 psf Bearing	78	30	5	6	Soil Class 4 - 2000 psf Bearing	72	30	5	6	Soil Class 3 - 3000 psf Bearing	72	30	5	6	Soil Class 3 - 3000 psf Bearing	72	30	5	6
Soil Class 5 - 1500 psf Bearing	64	30	6	6	Soil Class 4 - 2000 psf Bearing	75	30	5	6	Soil Class 3 - 3000 psf Bearing	75	30	5	6	Soil Class 3 - 3000 psf Bearing	75	30	5	6

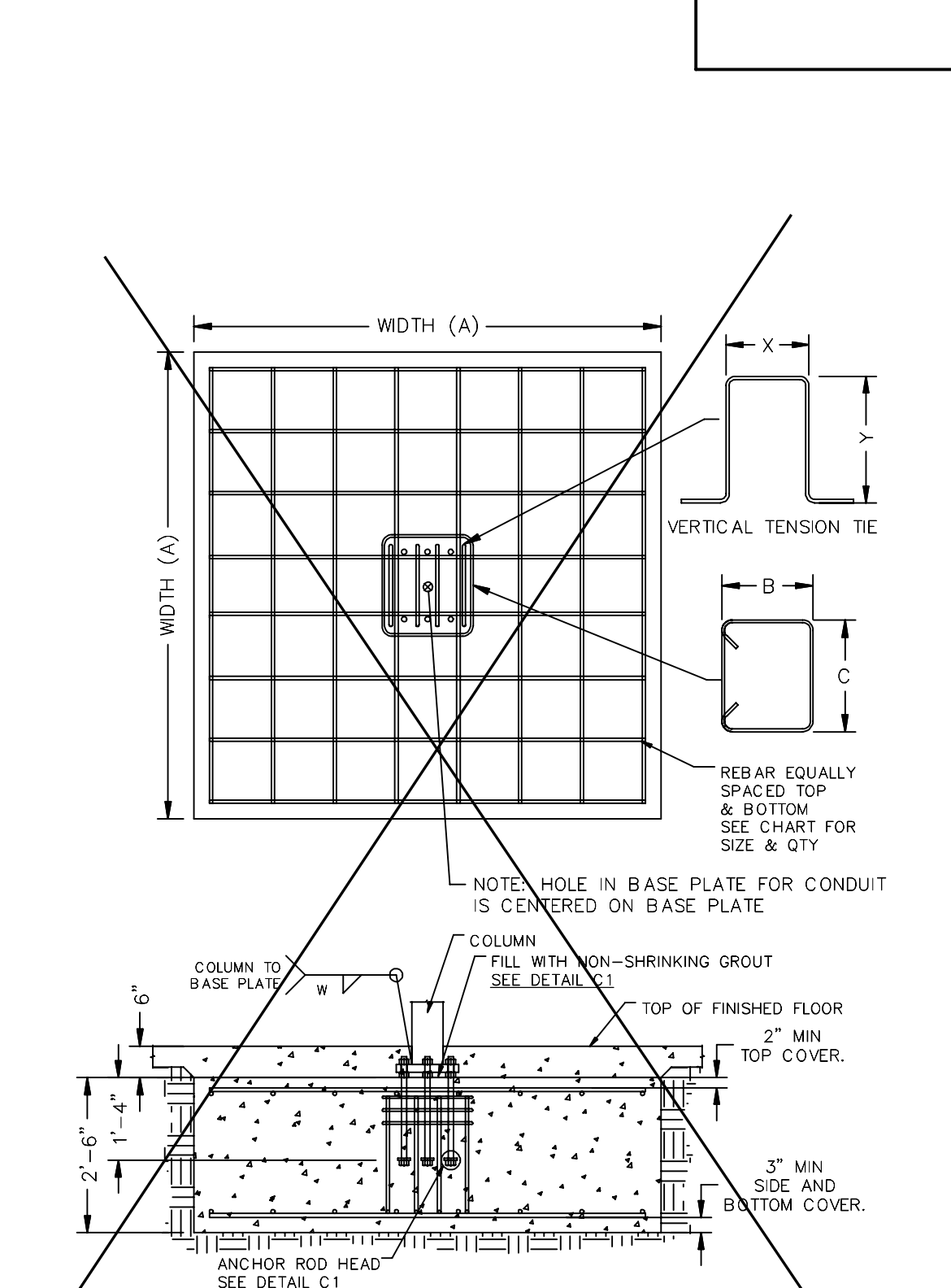

ICON Shelter Systems Inc
DISTINCTIVE STEEL SHEET PILING
WWW.ICONSTEELPIILING.COM
1455 LINCOLN AVE
HOLLAND MI, 49423
616.396.0919
800.748.0985
616.396.0944 FX

PRE-CHECK (PC) DOCUMENT
Code: 2019 CBC
A separate project application for construction is required.

LS3.0

SHADE STRUCTURE AT JOHN BIDWELL ELEMENTARY SCHOOL

SACRAMENTO CITY UNIFIED SCHOOL DISTRICT
SACRAMENTO, CA

Revision

Copyright © 2021 Rainforth Grau Architects. All rights reserved. Reproduction of these plans, either in whole or in part, including any form of copying and/or preparation of derivative works thereof, for any reason without prior written permission, is strictly prohibited.

30' WIDE RECTANGULAR HIP FOUNDATION PLAN

PROJECT NO. 21-1504.02
DATE: 4/7/22
SHEET **LS3.0**
AD0.08

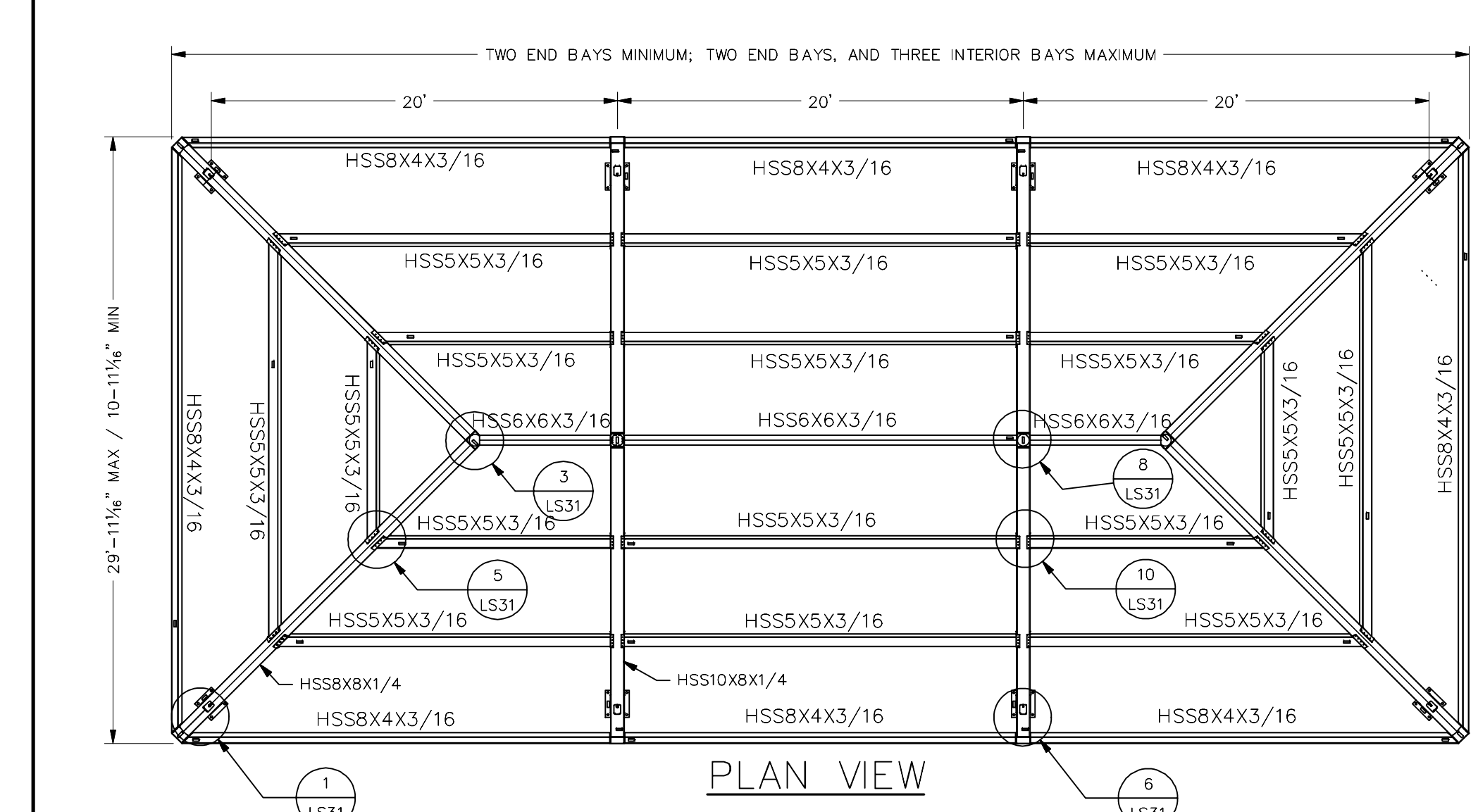
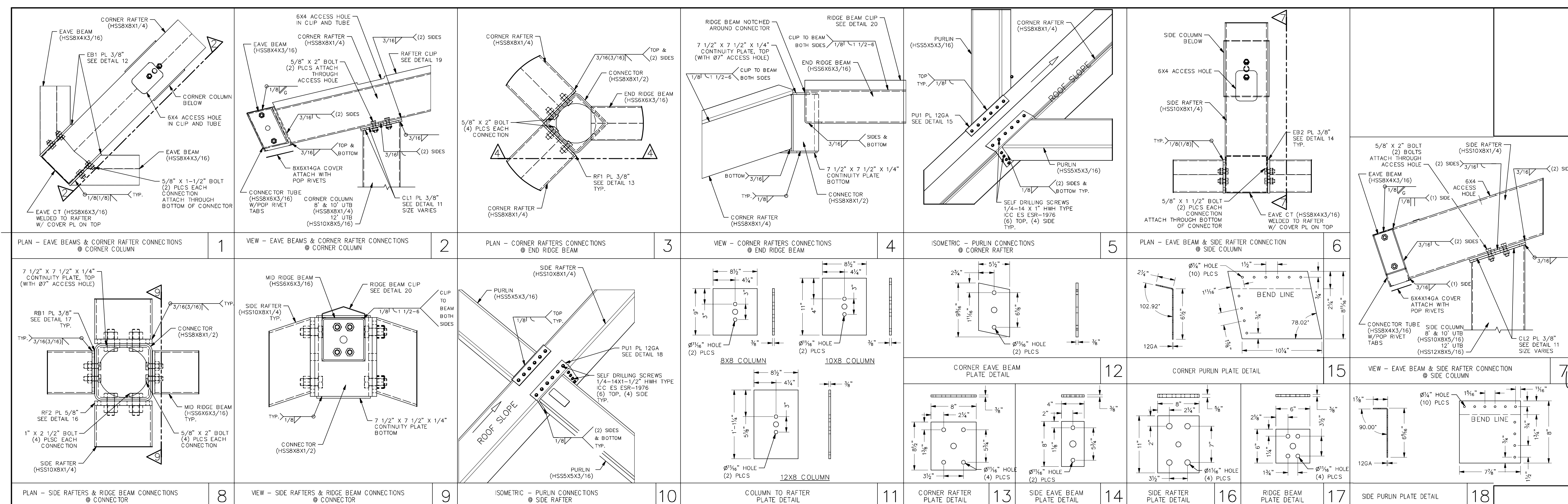

**NOTE:
QUANTITIES WILL VARY DEPENDING ON SHELTER SIZE ORDERED. PLEASE
REFER TO JOB SPECIFIC BILL OF MATERIALS AND INSTALLATION MANUAL.

ITEM	QTY	PART NUMBER	DESCRIPTION	MATERIAL	LENGTH	UNIT WEIGHT
1	4		CORNER COLUMN	**SEE NOTE BELOW		353 lbmass
2	*		SIDE COLUMN	**SEE NOTE BELOW		399 lbmass
3	2		LH SIDE EAVE BEAM	HSS8X4X3/16		311 lbmass
4	2		RH SIDE EAVE BEAM	HSS8X4X3/16		311 lbmass
5	2		END EAVE BEAM	HSS8X4X3/16		422 lbmass
6	*		SIDE EAVE BEAM	HSS8X4X3/16		287 lbmass
7	4		CORNER RAFTER	HSS8X8X1/4		607 lbmass
8	*		SIDE RAFTER	HSS10X8X1/4		474 lbmass
9	2		END RIDGE BEAM	HSS8X6X3/16		149 lbmass
10	*		MID RIDGE BEAM	HSS8X6X3/16		328 lbmass
11	*		CONNECTOR	HSS8X8X1/2		48 lbmass
12	2		LH SIDE PURLIN 1	HSS5X5X3/16		238 lbmass
13	2		RH SIDE PURLIN 1	HSS5X5X3/16		238 lbmass
14	2		END PURLIN 1	HSS5X5X3/16		278 lbmass
15	2		LH SIDE PURLIN 2	HSS5X5X3/16		167 lbmass
16	2		RH SIDE PURLIN 2	HSS5X5X3/16		167 lbmass
17	2		END PURLIN 2	HSS5X5X3/16		137 lbmass
18	*		MID PURLIN	HSS5X5X3/16		284 lbmass

**NOTE:
MATERIAL WILL VARY DEPENDING ON SHELTER SIZE ORDERED.

- CORNER COLUMN 8' UTB - (HSS8X8X1/4)
- SIDE COLUMN 8' UTB - (HSS10X8X5/16)
- CORNER COLUMN 10' UTB - (HSS8X8X1/4)
- SIDE COLUMN 10' UTB - (HSS10X8X5/16)
- CORNER COLUMN 12' UTB - (HSS10X8X5/16)
- SIDE COLUMN 12' UTB - (HSS12X8X5/16)

MODEL DESIGNATION

RH30X44	2 BAY
RH30X64	3 BAY
RH30X84	4 BAY
RH30X104	5 BAY

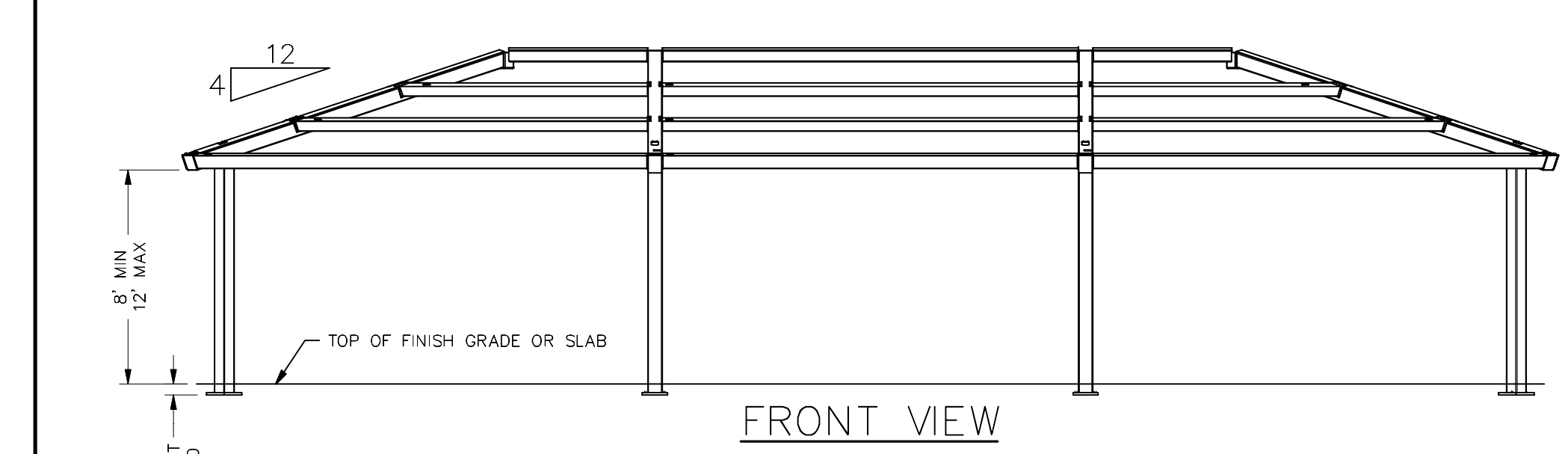

30' WIDE RECTANGULAR HIP

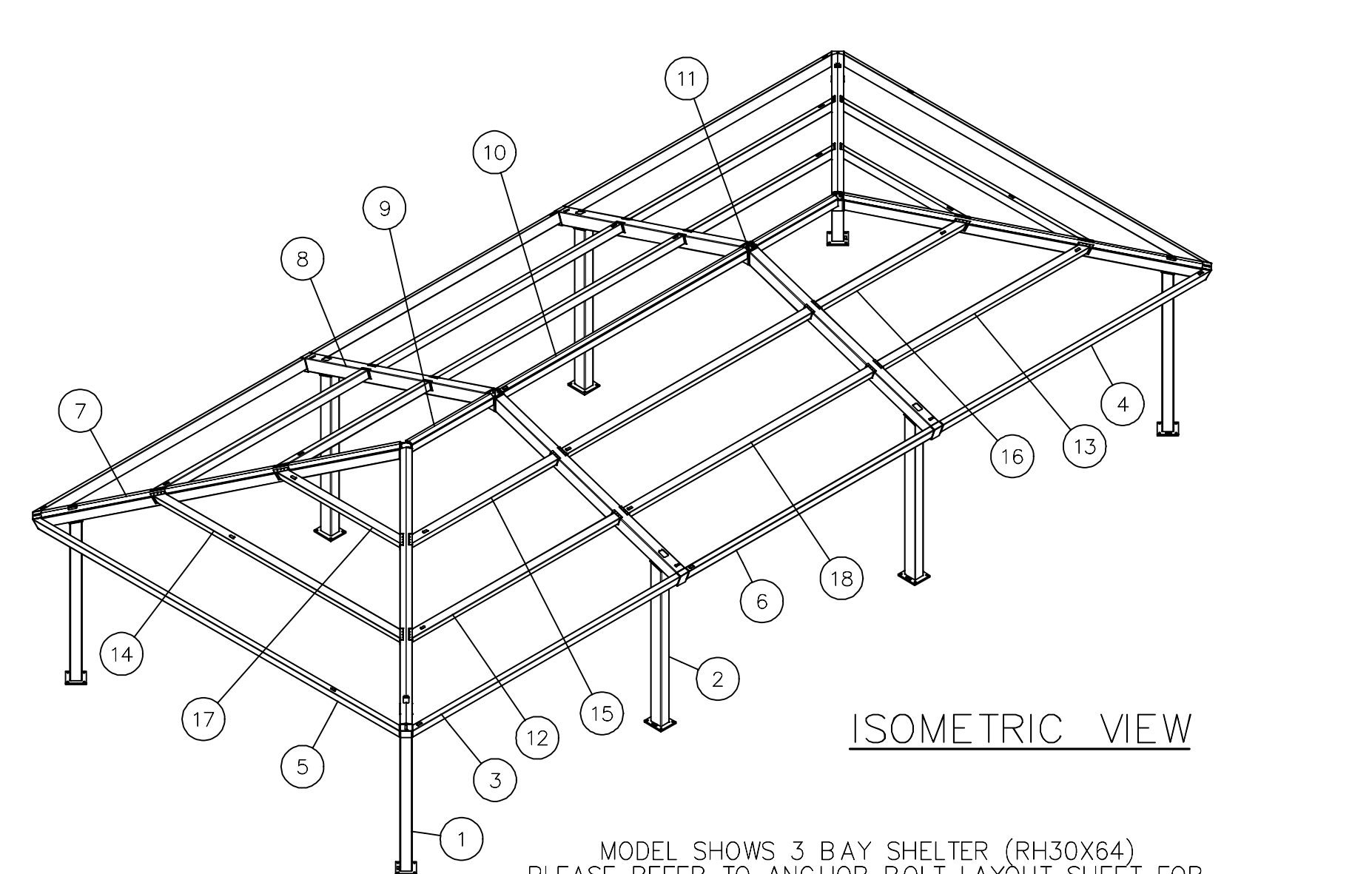
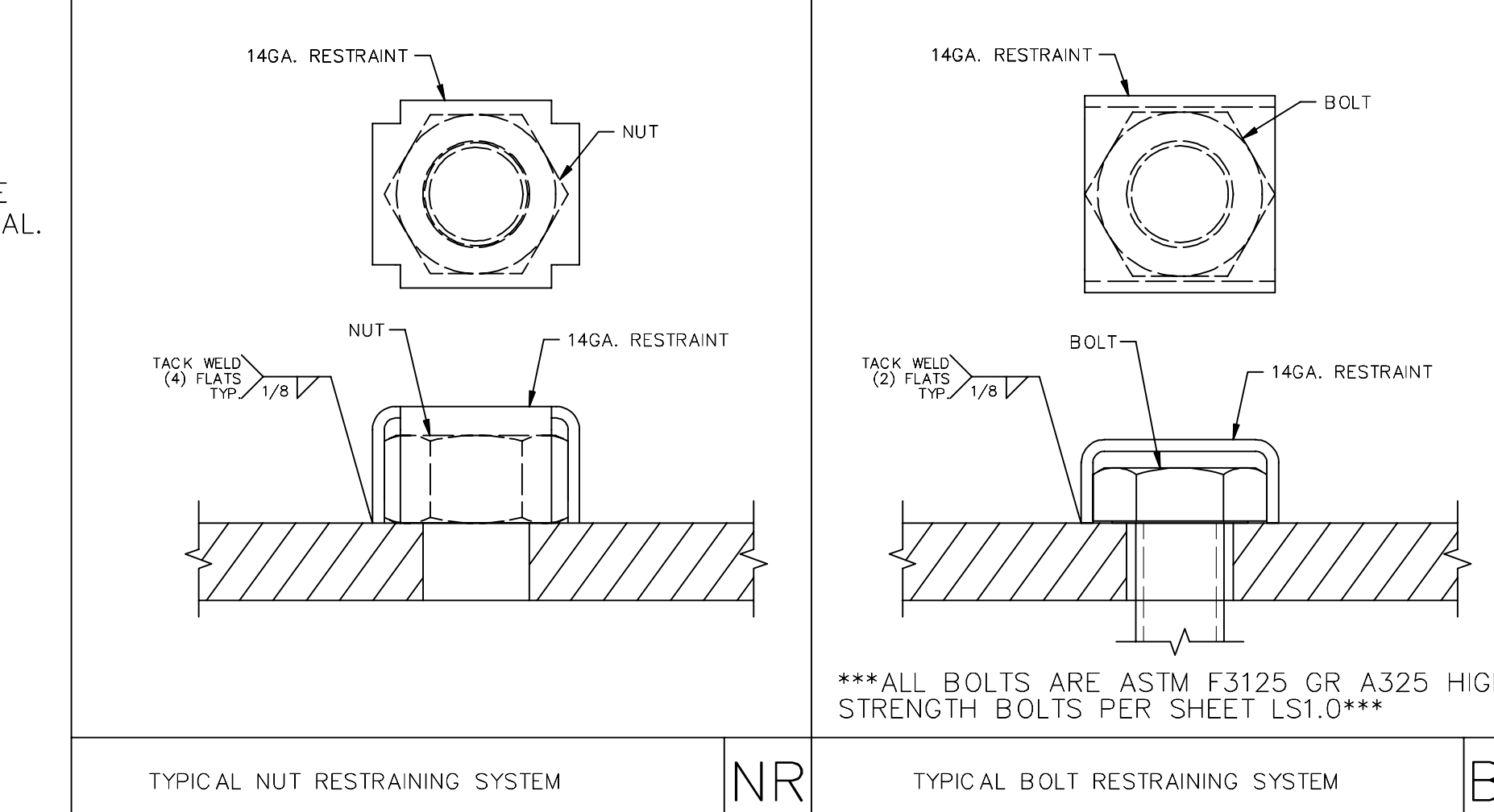

MODEL SHOWS 3 BAY SHELTER (RH30X64)
PLEASE REFER TO ANCHOR BOLT LAYOUT SHEET FOR
CORRECT COLUMN PLACEMENT BASED ON SIZE ORDERED

ICON STD	RH/USA-PC
DRAWN BY	ANGEL
DATE	4/2/2021
REV	
REV DATE	

JRMA
ARCHITECTS ENGINEERS
20254 RIVERVIEW, CA 95251
1.714.524.8730 F. 714.524.8735
WWW.JRMA.COM



APPROVED
DIV. OF THE STATE ARCHITECT
APP: 04-20013-PC
REVIEWED FOR
SS □ PS □ ACS □ CG □
DATE: 08/06/2021

30' WIDE
RECTANGULAR HIP
FRAMING &
CONNECTION DETAILS

ICON
Shelter Systems Inc
DISTINCTIVE STEEL SHELTER
SYSTEMS, INC.
WWW.ICONSHelters.COM
COPYRIGHT 2004, ICON SHELTER
SYSTEMS, INC.

1455 LINCOLN AVE
HOLLAND MI, 49423
616.396.0919
800.748.0985
616.396.0944 FX

LS3.1

PRE-CHECK (PC) DOCUMENT
Code: 2019 CBC
A separate project application for construction is required.

SHADE STRUCTURE AT JOHN BIDWELL
ELEMENTARY SCHOOL
SACRAMENTO CITY UNIFIED SCHOOL DISTRICT
SACRAMENTO, CA

Revision

30' WIDE
RECTANGULAR HIP
FRAMING &
CONNECTION DETAILS

Copyright © 2021 Rainforest Grau Architects. All rights reserved.
Reproduction of these plans, either in whole or in part, including
any form of copying and/or preparation of derivative works thereof,
for any reason without prior written permission, is strictly prohibited.

PROJECT NO.	21-1504.02
DATE:	4/7/22
SHEET	LS3.1

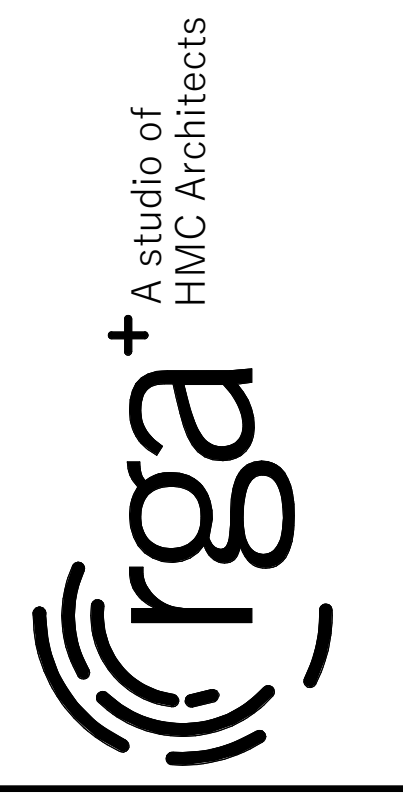

ELECTRICAL INFORMATION - RECTANGULAR HIP

ICON'S STANDARD ELECTRICAL IS DESIGNED TO ACCOMMODATE Ø1/2" CONDUIT WITH A Ø3" INLET HOLE ON THE BOTTOM OF EACH COLUMN. THE CONDUIT PATHWAY RUNS THROUGH THE COLUMN, RAFTER, AND RIDGE BEAM THROUGH ALL BOLTED CONNECTIONS AS SHOWN. IF YOU HAVE SPECIAL ELECTRICAL REQUIREMENTS, PLEASE OUTLINE ANY CHANGES BELOW AS DESCRIBED.

PLEASE NOTE: DESIGN LIMITATIONS ON HOLE/CUTOUT SIZES MAY APPLY. ICON WILL REACH OUT TO DISCUSS ANY SUCH LIMITATIONS AS NEEDED.

NOTE: ICON SHELTER FRAME IS NOT UL LISTED TO ACT AS A CONDUIT FOR ELECTRICAL WIRING. CONSULT LOCAL BUILDING CODES WHEN PLANNING YOUR ELECTRICAL SYSTEM.

PRELIMINARY: NOT FOR CONSTRUCTION

- STEPS:**
1. CONDUIT HOLE SIZE (DETAIL A)
 2. ELECTRICAL EXIT HOLES (DETAIL B)
 3. ELECTRICAL ACCESS & COVER PLATES (DETAIL C)
 4. ELECTRICAL CONDUIT PATHWAY (DETAIL D)

IF REQUIRED, PLEASE DRAW THE NECESSARY ELECTRICAL CONDUIT PATHWAY ON THE FRAME SHEET OF THIS PRELIMINARY.

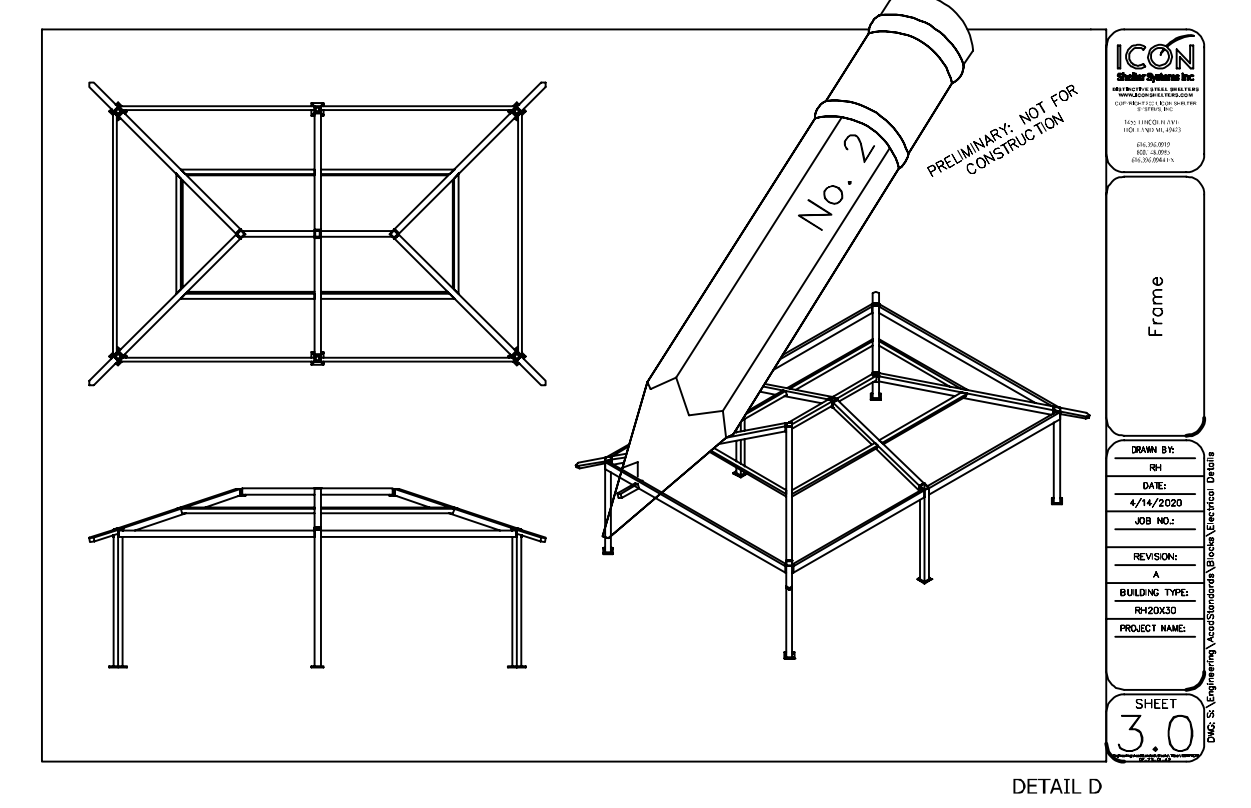

OPTIONAL EXIT HOLES
 IF REQUIRED, EXIT HOLES FOR LIGHTING, ETC. CAN BE PLACED IN THE RIDGE BEAM AND/OR CONNECTOR TUBE WITH 14ga COVER PLATE AS SHOWN (CHARGES APPLY). USE FRAME SHEET OF THIS PRELIMINARY TO SPECIFY REQUIRED EXIT HOLE LOCATIONS AND SIZE.

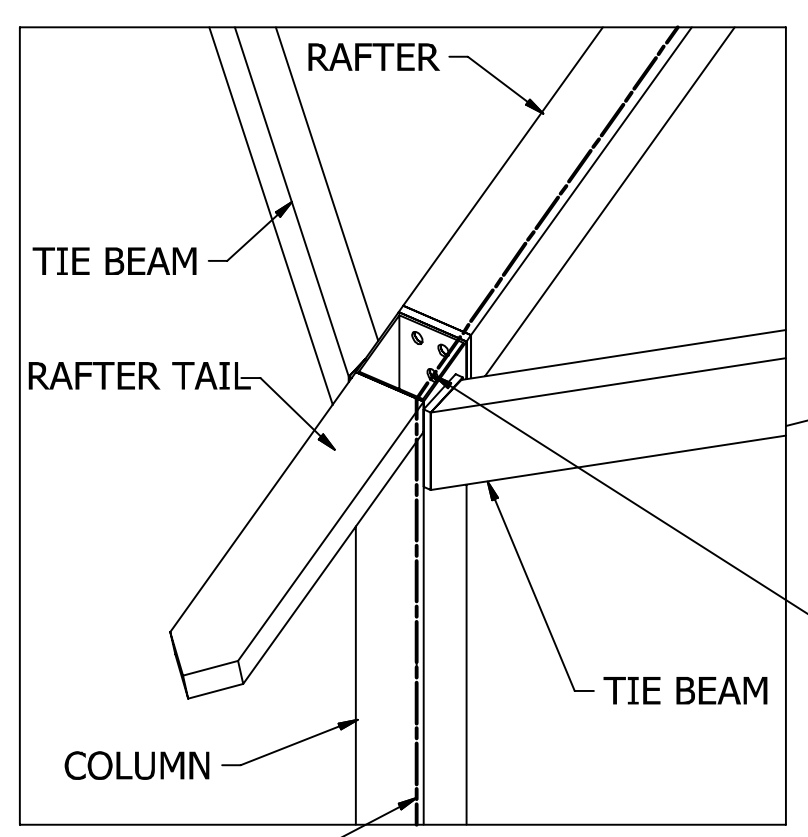
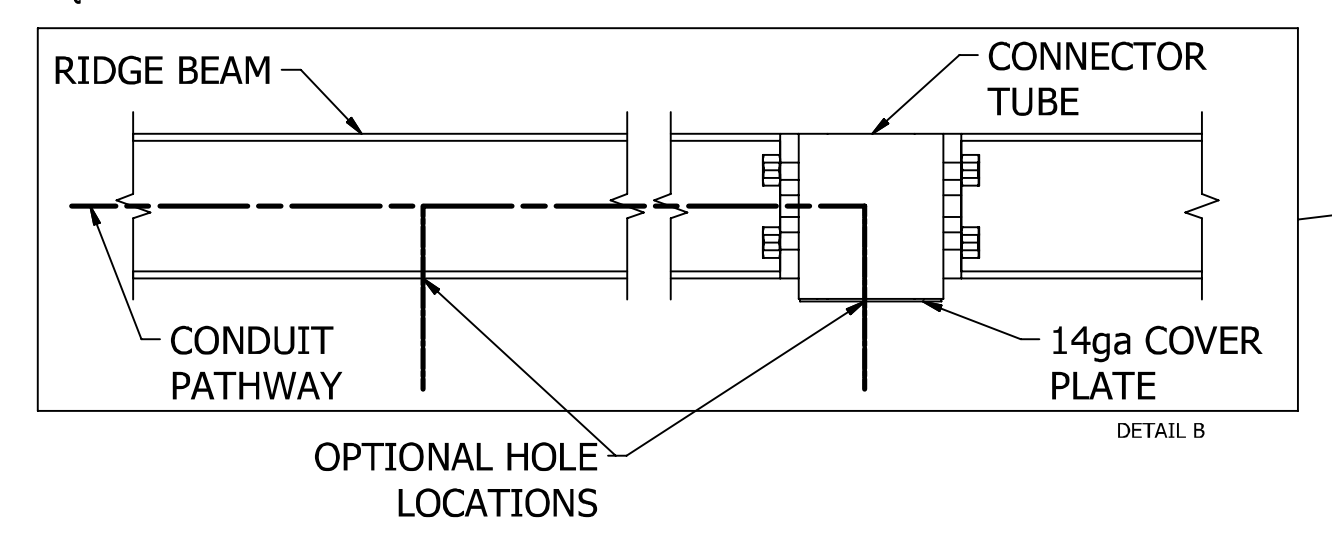

ICON PROVIDES A MINIMUM OF (1) 3/4" HOLE AT EACH CONNECTION FOR 1/2" CONDUIT. IF APPLICABLE, PLEASE SPECIFY REQUIRED CONDUIT SIZE: (CHARGES APPLY)

- 3/4" CONDUIT (1" HOLES)
- 1" CONDUIT (1 1/4" HOLES)
- OTHER (PLEASE SPECIFY)

CONDUIT PATHWAY PROVIDED FOR EACH COLUMN.

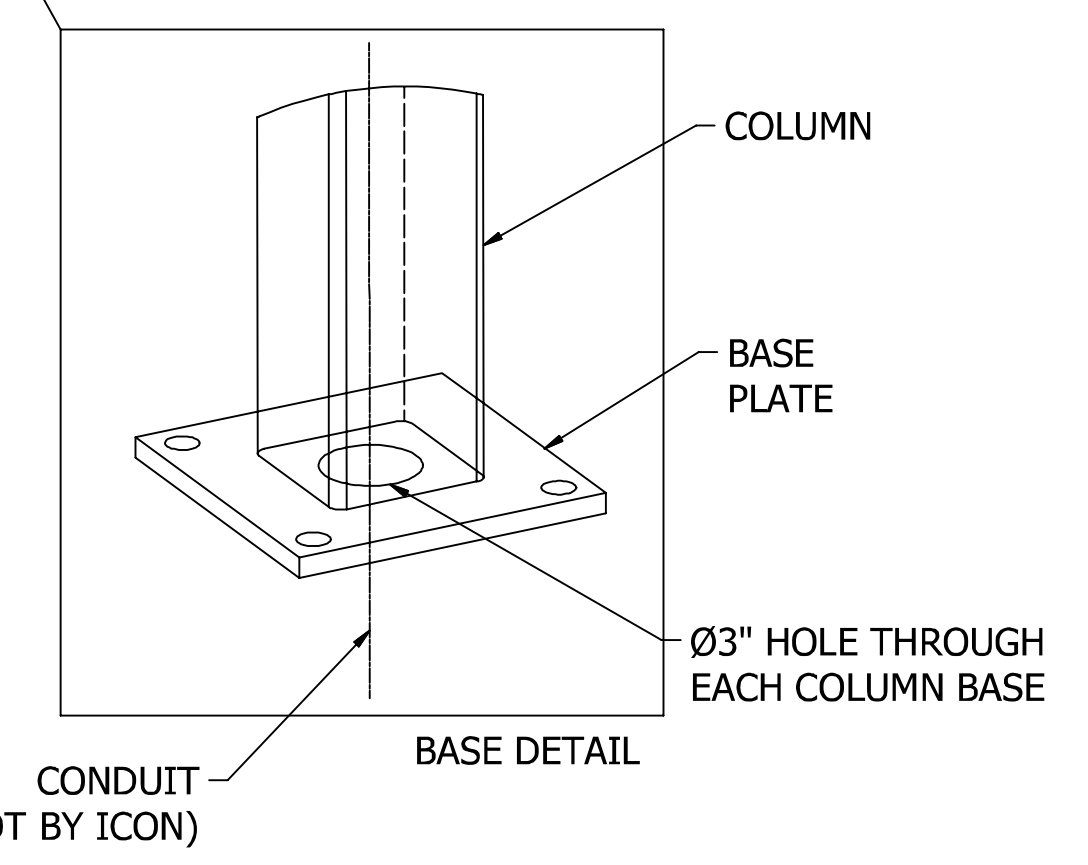

OPTIONAL CUTOUTS
 USE FRAME SHEET OF THIS PRELIMINARY TO SPECIFY REQUIRED CUTOUT LOCATIONS (CHARGES APPLY). SEE REQUIRED INFO BELOW

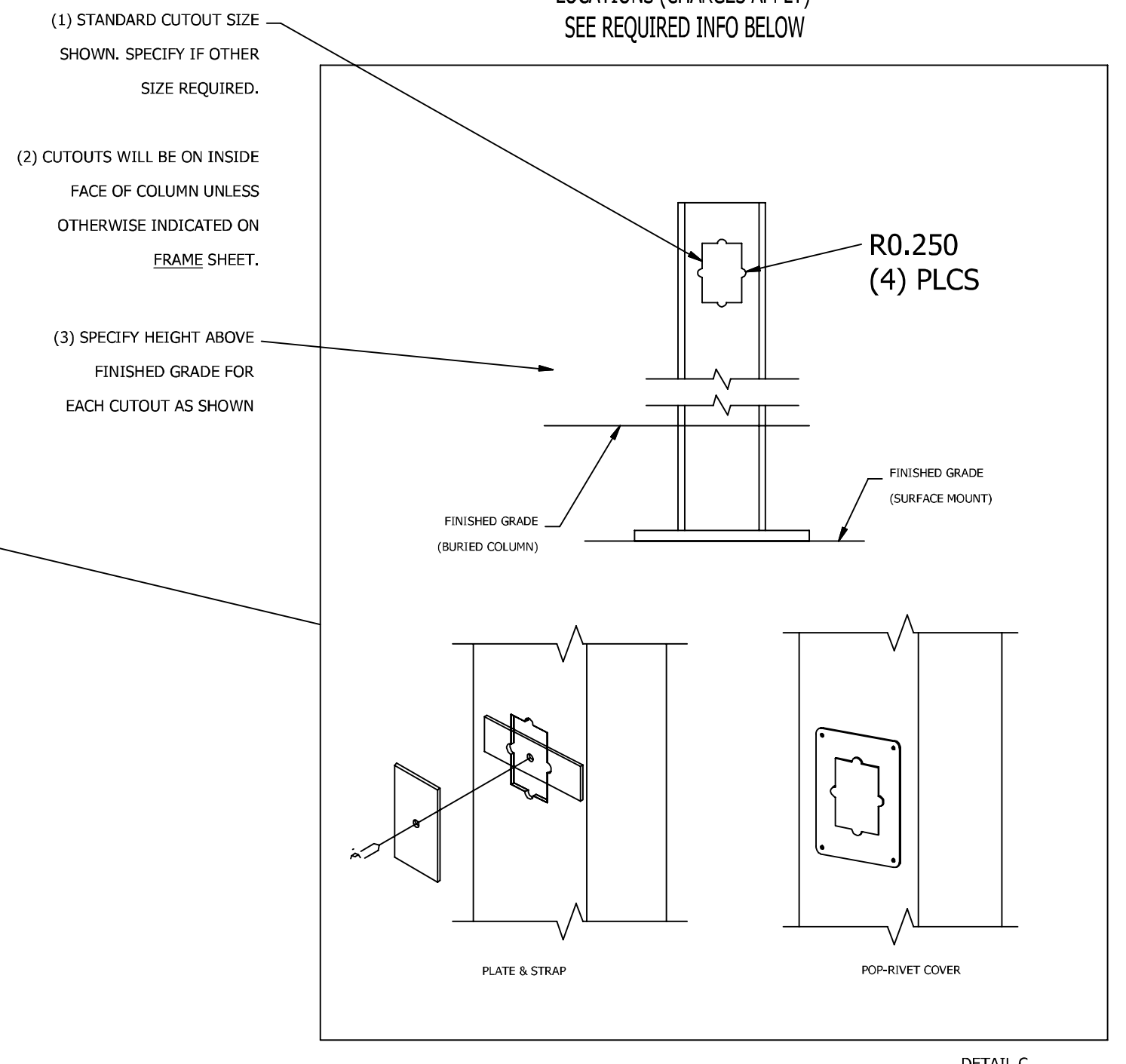

(4) COVER PLATES PROVIDED UPON REQUEST (CHARGES APPLY). PLEASE SPECIFY TYPE AND QUANTITY REQUIRED:

- PLATE & STRAP
 - POP-RIVET COVER PLATE
- HOW MANY REQUIRED? _____

ICON STD	RH/OSA-PC
DRAWN BY	ANGEL
DATE	4/2/2021
REV	
REV DATE	

JRMA
 ARCHITECTS ENGINEERS
 2200 SATORI ST BRSA, CA 95821
 1714 24th ST #117, FALCON, NY
 WWW.JRMA.COM

PROFESSIONAL ENGINEER
 MICHAEL D. JORDAN
 LICENSE NO. 50898
 STATE OF CALIFORNIA

4/29/2021

APPROVED
 DIR. OF THE STATE ARCHITECT
 APP: 04-20013-PC
 REVIEWED FOR
 SS PLS ACS CG
 DATE: 08/06/2021

ELECTRICAL ACCESS

ICON Shelter Systems Inc
 DISTINCTIVE STEEL SHELTERS
 WWW.ICONSHELTERS.COM
 COPYRIGHT 2004, ICON SHELTER SYSTEMS, INC.
 1455 LINCOLN AVE
 HOLLAND MI, 49423
 616.396.0919
 800.748.0985
 616.396.0944 FX

PRE-CHECK (PC) DOCUMENT
 Code: 2019 CBC
 A separate project application for construction is required.

LS5.0

SHADE STRUCTURE AT JOHN BIDWELL ELEMENTARY SCHOOL
 SACRAMENTO CITY UNIFIED SCHOOL DISTRICT
 SACRAMENTO, CA

Revision	
----------	--

Copyright © 2021 Rainforth Grau Architects. All rights reserved. Reproduction of these plans, either in whole or in part, including any form of copying and/or preparation of derivative works thereof, for any reason without prior written permission, is strictly prohibited.

ELECTRICAL ACCESS

PROJECT NO. 21-1504.02
 DATE: 4/7/22
 SHEET

LS5.0
 AD0.11