



Sacramento City Unified School District

Business Services

Contracts Office

5735 47th Avenue • Sacramento, CA 95824

(916) 643-2464

Gerardo Castillo, Chief Business Officer

Kimberly Teague, Contract Specialist

BID INSTRUCTIONS / BID FORMS

For

OUTDOOR LEARNING AREA

AND LANDSCAPING AT

JOHN F. KENNEDY HIGH SCHOOL

Bid No. 0525-402

Bids Due: August 15, 2016

TABLE OF CONTENTS

Procurement and Contracting Requirements

<u>Division 0</u>	<u>Section</u>	<u>Title</u>
	00 01 01	Project Title Page
	00 01 10	Table of Contents
	00 01 15	List of Drawings and Tables

Solicitation

<u>Division 0</u>	<u>Section</u>	<u>Title</u>
	00 11 16	Notice to Bidders

Instructions for Procurement

<u>Division 0</u>	<u>Section</u>	<u>Title</u>
	00 21 13	Instructions to Bidders
	00 21 13.1	Bidder Information and Forms

Available Information

<u>Division 0</u>	<u>Section</u>	<u>Title</u>
	00 31 19	Existing Conditions
	00 31 32	Geotechnical Data

Procurement Forms and Supplements

<u>Division 0</u>	<u>Section</u>	<u>Title</u>
	00 41 13	Bid Form and Proposal
	00 43 13	Bid Bond
	00 43 36	Designated Subcontractors List
	00 45 01	Site Visit Certification
	00 45 19	Non-Collusion Declaration

LIST OF DRAWINGS AND TABLES

DRAWINGS

<u>Sheet number</u>	<u>Description</u>
L-1	Layout Plan
L-2	Grading Plan
L-3	Irrigation Plan
L-4	Construction Details
L-5	Irrigation Details

END OF DOCUMENT

NOTICE TO BIDDERS

1. Notice is hereby given that the governing board ("Board") of the Sacramento City Unified School District ("District") will receive sealed bids for the following project, Bid No. 0525-402, Outdoor Learning Area and Landscaping at John F. Kennedy High School ("Project" or "Contract"):
2. The Project consists of landscaping, irrigation, grading, concrete, decomposed granite walkways and exterior furniture, per plans and specifications prepared by Great Valley Design, Inc. 1219 Spruce Lane, Davis, CA, (530) 792-7095.
3. The estimate for this project is \$75,000. To bid on this Project, the Bidder is required to possess one or more of the following State of California Contractor Licenses: B – General Building; or C-27, Landscaping.

The Bidder's license(s) must remain active and in good standing throughout the term of the Contract.
4. To bid on this Project, the Bidder is required to be registered as a public works contractor with the Department of Industrial Relations. The Bidder's registration must remain active throughout the term of the Contract.
5. The District utilizes construction program management software, e-Builder™, for its construction projects. To register with e-Builder and access bid packages, please go to <http://app.e-builder.net/Bidders/Landing.aspx?BidPackageID={d62d8340-34af-4964-85fe-6468bf80fd52}>. This link will provide registration instructions and allow you access to the bid documents, plans and specifications. All bid information, documents, etc. will be in e-Builder. If you need technical assistance, please contact technical support at e-Builder, (888) 288-5717, or support@e-builder.net. You may also call the Planning & Construction Office (916) 264-4075 x1020 or x1026 for assistance.
6. **Sealed Bids will be received until 2:00 p.m., August 15, 2016**, at the Serna Center, 5735 47th Avenue, Sacramento, California, 95824 at or after which time the bids will be opened and publicly read aloud. Bids may also be submitted electronically through e-Builder™. Any bid that is submitted after this time shall be non-responsive and returned to the bidder. Any claim by a bidder of error in its bid must be made in compliance with section 5100 et seq. of the Public Contract Code.
7. **IMPORTANT NOTICE TO BIDDERS:** Bidders must complete the "Determination of Bidder Responsibility Questionnaire" (included in Bid Form) to be determined responsible for award and to be responsive to the bid announcement. If a Bidder has completed the questionnaire in response to a District project since January 1, 2015, only the certification stating the previously submitted data is still true and accurate, is required.
8. All bids shall be on the form provided by the District. Each bid must conform and be responsive to all pertinent Contract Documents, including, but not limited to, the Instructions to Bidders.
9. A bid bond by an admitted surety insurer on the form provided by the District, cash, or a cashier's check or a certified check, drawn to the order of the Sacramento City Unified School District, in the amount of ten percent (10%) of the total bid price, shall accompany the Bid Form and Proposal, as a guarantee that the Bidder will, within seven (7) calendar days after the date of the Notice of Award, enter into a contract with the District for the performance of the services as stipulated in the bid.

10. **A mandatory pre-bid conference and site visit will be held on August 9, 2016, at 9:00 a.m.** at 6715 Gloria Drive, Sacramento 95831. All participants are required to meet in front of the school, near the flagpole. Bidders are required to arrive for the pre-bid conference on time and to sign an attendance list.
11. The successful Bidder shall be required to furnish a 100% Performance Bond and a 100% Payment Bond if it is awarded the contract for the Work.
12. The successful Bidder may substitute securities for any monies withheld by the District to ensure performance under the Contract, in accordance with the provisions of section 22300 of the Public Contract Code.
13. The Contractor and all Subcontractors under the Contractor shall pay all workers on all work performed pursuant to this Contract not less than the general prevailing rate of per diem wages and the general prevailing rate for holiday and overtime work as determined by the Director of the Department of Industrial Relations, State of California, for the type of work performed and the locality in which the work is to be performed within the boundaries of the District, pursuant to sections 1770 et seq. of the California Labor Code. Prevailing wage rates are also available from the District or on the Internet at: <<http://www.dir.ca.gov>>.
14. This Project is subject to labor compliance monitoring and enforcement by the Department of Industrial Relations pursuant to Labor Code section 1771.4 and subject to the requirements of Title 8 of the California Code of Regulations. The Contractor and all Subcontractors under the Contractor shall furnish electronic certified payroll records directly to the Labor Commissioner weekly or within ten (10) days of any request by the District or the Labor Commissioner. The successful Bidder shall comply with all requirements of Division 2, Part 7, Chapter 1, of the Labor Code.
15. The District shall award the Contract, if it awards it at all, to the lowest responsive responsible bidder based on the base bid amount only.
16. The Board reserves the right to reject any and all bids and/or waive any irregularity in any bid received. If the District awards the Contract, the security of unsuccessful bidder(s) shall be returned within sixty (60) days from the time the award is made. Unless otherwise required by law, no bidder may withdraw its bid for ninety (90) days after the date of the bid opening.

END OF DOCUMENT

INSTRUCTIONS TO BIDDERS

Contractors shall follow the instructions in this document, and shall submit all documents, forms, and information required for consideration of a Bid.

Sacramento City Unified School District ("District") will evaluate information submitted by the apparent low Bidder and, if incomplete or unsatisfactory to District, Bidder's bid may be rejected at the sole discretion of District.

17. Bids are requested for a general construction contract, or work described in general, for the following project ("Project" or "Contract"):

Outdoor Learning Area and Landscaping at John F. Kennedy High School

18. District will receive sealed Bids from Bidders as stipulated in the Notice to Bidders.
19. **IMPORTANT NOTICE TO BIDDERS:** Bidders must complete the "Determination of Bidder Responsibility Questionnaire" (included in Bid Form) to be determined responsible for award and to be responsive to the bid announcement. If a Bidder has completed the questionnaire in response to a District project since January 1, 2015, only the certification stating the previously submitted data is still true and accurate, is required.
20. Bidders must submit Bids on the Bid Form and Proposal and all other required District forms. Bids not submitted on the District's required forms shall be deemed non-responsive and shall not be considered. Additional sheets required to fully respond to requested information are permissible.
21. Bidders must supply all information required by each Bid Document. Bids must be full and complete. District reserves the right in its sole discretion to reject any Bid as non-responsive as a result of any error or omission in the Bid. Bidders must complete and submit all of the following documents with the Bid Form and Proposal:
- a. Bid Bond on the District's form or other security.
 - b. Designated Subcontractors List.
 - c. Site-Visit Certification, if a site visit was required.
 - d. Non-Collusion Declaration.
22. Bidders must submit with their Bids cash, a cashier's check or a certified check payable to District, or a bid bond by an admitted surety insurer of not less than ten percent (10%) of amount of base Bid, plus all additive alternates. If Bidder chooses to provide a Bid Bond as security, Bidder must use the required form of corporate surety provided by District. The Surety on Bidder's Bid Bond must be an insurer admitted in the State of California and authorized to issue surety bonds in the State of California. Bids submitted without necessary bid security will be deemed non-responsive and will not be considered.
23. If Bidder to whom Contract is awarded fails or neglects to enter into Contract and submit required bonds, insurance certificates, and all other required documents, within **SEVEN (7)** calendar days after the date of the Notice of Award, District may deposit Bid Bond, cash, cashier's check, or certified check for collection, and proceeds thereof may be retained by District as liquidated damages for failure of Bidder to enter into Contract, in the sole discretion of District. It is agreed that calculation of damages District may suffer as a result

of Bidder's failure to enter into the Contract would be extremely difficult and impractical to determine and that the amount of the Bidder's required bid security shall be the agreed and conclusively presumed amount of damages.

24. Bidders must submit with the Bid the Designated Subcontractors List for those subcontractors who will perform any portion of Work, including labor, rendering of service, or specially fabricating and installing a portion of the Work or improvement according to detailed drawings contained in the plans and specifications, in excess of one half of one percent (0.5%) of total Bid. All of the listed subcontractors are required to be registered as a public works contractor with the Department of Industrial Relations. The subcontractor's registration must remain active throughout the term of the Contract. Failure to submit this list when required by law shall result in Bid being deemed non-responsive and the Bid will not be considered.
 - a. An inadvertent error in listing the California contractor license number on the Designated Subcontractors List shall not be grounds for filing a bid protest or grounds for considering the bid nonresponsive if the correct contractor's license number is submitted to the District within 24 hours after the bid opening and the corrected number corresponds with the submitted name and location for that subcontractor.
 - b. An inadvertent error listing an unregistered subcontractor shall not be grounds for filing a bid protest or grounds for considering the bid nonresponsive provided that any of the following apply:
 - (1) The subcontractor is registered prior to the bid opening.
 - (2) The subcontractor is registered and has paid the penalty registration fee within 24 hours after the bid opening.
 - (3) The subcontractor is replaced by another registered subcontractor pursuant to Public Contract Code section 4107.
25. If a mandatory pre-bid conference and site visit ("Site Visit") is requested as referenced in the Notice to Bidders, then Bidders must submit the Site-Visit Certification with their Bid. District will transmit to all prospective Bidders of record such Addenda as District in its discretion considers necessary in response to questions arising at the Site Visit. Oral statements shall not be relied upon and will not be binding or legally effective. Addenda issued by the District as a result of the Site Visit, if any, shall constitute the sole and exclusive record and statement of the results of the Site Visit.
26. Bidders shall submit the Non-Collusion Declaration with their Bids. Bids submitted without the Non-Collusion Declaration shall be deemed non-responsive and will not be considered.
27. Bids shall be clearly written without erasure or deletions. District reserves the right to reject any Bid containing erasures or deletions.
28. Bidders shall not modify the Bid Form and Proposal or qualify their Bids. Bidders shall not submit to the District a scanned, re-typed, word-processed, or otherwise recreated version of the Bid Form and Proposal or other District-provided document.
29. The Bidder and all Subcontractors under the Contractor shall pay all workers on all work performed pursuant to this Contract not less than the general prevailing rate of per diem wages and the general prevailing rate for holiday and overtime work as determined by the Director of the Department of Industrial Relations, State of California, for the type of work performed and the locality in which the work is to be performed within the boundaries of the District, pursuant to sections 1770 et seq. of the California Labor Code. Copies of the general prevailing rates of per diem wages for each craft, classification, or type of worker needed to

execute the Contract, as determined by Director of the State of California Department of Industrial Relations, are available upon request at the District's principal office. Prevailing wage rates are also available on the internet at <http://www.dir.ca.gov>.

30. Submission of Bid signifies careful examination of Contract Documents and complete understanding of the nature, extent, and location of Work to be performed. Bidders must complete the tasks listed below as a condition to bidding, and submission of a Bid shall constitute the Bidder's express representation to District that Bidder has fully completed the following:
- a. Bidder has visited the Site, if required, and has examined thoroughly and understood the nature and extent of the Contract Documents, Work, Site, locality, actual conditions, as-built conditions, and all local conditions and federal, state and local laws, and regulations that in any manner may affect cost, progress, performance, or furnishing of Work or that relate to any aspect of the means, methods, techniques, sequences, or procedures of construction to be employed by Bidder and safety precautions and programs incident thereto;
 - b. Bidder has conducted or obtained and has understood all examinations, investigations, explorations, tests, reports, and studies that pertain to the subsurface conditions, as-built conditions, underground facilities, and all other physical conditions at or contiguous to the Site or otherwise that may affect the cost, progress, performance, or furnishing of Work, as Bidder considers necessary for the performance or furnishing of Work at the Contract Sum, within the Contract Time, and in accordance with the other terms and conditions of Contract Documents, including specifically the provisions of the General Conditions; and no additional examinations, investigations, explorations, tests, reports, studies, or similar information or data are or will be required by Bidder for such purposes;
 - c. Bidder has correlated its knowledge and the results of all such observations, examinations, investigations, explorations, tests, reports, and studies with the terms and conditions of the Contract Documents;
 - d. Bidder has given the District prompt written notice of all conflicts, errors, ambiguities, or discrepancies that it has discovered in or among the Contract Documents and the actual conditions, and the written resolution thereof by the District is acceptable to Bidder;
 - e. Bidder has made a complete disclosure in writing to the District of all facts bearing upon any possible interest, direct or indirect, that Bidder believes any representative of the District or other officer or employee of the District presently has or will have in this Contract or in the performance thereof or in any portion of the profits thereof;
 - f. Bidder must, prior to bidding, perform the work, investigations, research, and analysis required by this document and that Bidder represented in its Bid Form and Proposal and the Agreement that it performed prior to bidding. Contractor under this Contract is charged with all information and knowledge that a reasonable bidder would ascertain from having performed this required work, investigation, research, and analysis. Bid prices must include entire cost of all work "incidental" to completion of the Work.
 - g. Conditions Shown on the Contract Documents: Information as to underground conditions, as-built conditions, or other conditions or obstructions, indicated in the Contract Documents, e.g., on Drawings or in Specifications, has been obtained with reasonable care, and has been recorded in good faith. However, District only

warrants, and Contractor may only rely, on the accuracy of limited types of information.

- (1) As to above-ground conditions or as-built conditions shown or indicated in the Contract Documents, there is no warranty, express or implied, or any representation express or implied, that such information is correctly shown or indicated. This information is verifiable by independent investigation and Contractor is required to make such verification as a condition to bidding. In submitting its Bid, Contractor shall rely on the results of its own independent investigation. In submitting its Bid, Contractor shall not rely on District-supplied information regarding above-ground conditions or as-built conditions.
- (2) As to any subsurface condition shown or indicated in the Contract Documents, Contractor may rely only upon the general accuracy of actual reported depths, actual reported character of materials, actual reported soil types, actual reported water conditions, or actual obstructions shown or indicated. District is not responsible for the completeness of such information for bidding or construction; nor is District responsible in any way for any conclusions or opinions of Contractor drawn from such information; nor is the District responsible for subsurface conditions that are not specifically shown (for example, District is not responsible for soil conditions in areas contiguous to areas where a subsurface condition is shown).

h. Conditions Shown in Reports and Drawings Supplied for Informational Purposes: Reference is made to the document entitled Geotechnical Data, and the document entitled Existing Conditions, for identification of:

- (1) Subsurface Conditions: Those reports of explorations and tests of subsurface conditions at or contiguous to the Site that have been utilized by Architect in preparing the Contract Documents; and
- (2) Physical Conditions: Those drawings of physical conditions in or relating to existing surface or subsurface structures at or contiguous to the Site that has been utilized by Architect in preparing the Contract Documents.
- (3) These reports and drawings are **not** Contract Documents and, except for any "technical" data regarding subsurface conditions specifically identified in Geotechnical Data and Existing Conditions, and underground facilities data, Contractor may not in any manner rely on the information in these reports and drawings. Subject to the foregoing, Contractor must make its own independent investigation of all conditions affecting the Work and must not rely on information provided by District.

31. Bidders may examine any available "as-built" drawings of previous work by giving District reasonable advance notice. District will not be responsible for accuracy of "as-built" drawings. The document entitled Existing Conditions applies to all supplied "as-built" drawings.
32. All questions about the meaning or intent of the Contract Documents are to be directed in writing to the District. Interpretations or clarifications considered necessary by the District in response to such questions will be issued in writing by Addenda emailed, faxed, mailed, or delivered to all parties recorded by the District as having received the Contract Documents. Questions received less than **SEVEN (7)** calendar days prior to the date for opening Bids may not be answered. Only questions answered by formal written Addenda will be binding. Oral and other interpretations or clarifications will be without legal effect.

33. Addenda may also be issued to modify other parts of the Contract Documents as deemed advisable by the District.
34. Each Bidder must acknowledge each Addendum in its Bid Form and Proposal by number or its Bid shall be considered non-responsive. Each Addendum shall be part of the Contract Documents. A complete listing of Addenda may be secured from the District.
35. Bids shall be based on products and systems specified in Contract Documents or listed by name in Addenda. Whenever in the Specifications any materials, process, or article is indicated or specified by grade, patent, or proprietary name, or by name of manufacturer, that Specification shall be deemed to be followed by the words "or equal." Bidder may, unless otherwise stated, offer any material, process, or article that shall be substantially equal or better in every respect to that so indicated or specified. The District is not responsible and/or liable in any way for a Contractor's damages and/or claims related, in any way, to that Contractor's basing its bid on any requested substitution that the District has not approved. Contractors and materials suppliers who submit requests for substitutions prior to the award of the Contract must do so in writing and in compliance with Public Contract Code section 3400. All requests must comply with the following:
 - a. District must receive any request for substitution a minimum of **TEN (10)** calendar days prior to bid opening.
 - b. Within 35 days after the date of the Notice of Award, the Successful Bidder shall submit data substantiating a request for substitution containing sufficient information to assess acceptability of product or system and impact on Project, including, without limitation, the requirements specified in the Special Conditions and the Specifications. Insufficient information shall be grounds for rejection of substitution.
 - c. Approved substitutions, if any, shall be listed in Addenda. District reserves the right not to act upon submittals of substitutions until after bid opening.
 - d. Substitutions may be requested after Contract has been awarded only if indicated in and in accordance with requirements specified in the Special Conditions and the Specifications.
36. All Bids must be sealed, and marked with name and address of the Bidder, Project Name, date and time of bid opening. Bids will be received as indicated in the Notice to Bidders.
 - a. Mark envelopes with the name of the Project.
 - b. Bids must be submitted to the Contracts Office by date and time shown in the Notice to Bidders.
 - c. Bids must contain all documents as required herein.
37. Bids will be opened at or after the time indicated for receipt of bids.
38. This Contract may include alternates. Alternates are defined as alternate products, materials, equipment, systems, methods, or major elements of the construction that may, at the District's option and under terms established in the Contract and pursuant to section 20103.8 of the Public Contract Code, be selected for the Work.
39. The District shall award the Contract, if it awards it at all, to the lowest responsive responsible bidder based on the criteria as indicated in the Notice to Bidders. In the event two or more responsible bidders submit identical bids, the District shall select the Bidder to whom to award the Contract by lot.

40. Time for Completion: District may issue a Notice to Proceed within **THREE (3)** months from the date of the Notice of Award. Once Contractor has received the Notice to Proceed, Contractor shall complete the Work within the period of time indicated in the Contract Documents.
- a. In the event that the District desires to postpone issuing the Notice to Proceed beyond this three-month period, it is expressly understood that with reasonable notice to the Contractor, the District may postpone issuing the Notice to Proceed.
 - b. It is further expressly understood by Contractor that Contractor shall not be entitled to any claim of additional compensation as a result of the postponement of the issuance of the Notice to Proceed beyond a three-month period. If the Contractor believes that a postponement of issuance of the Notice to Proceed will cause a hardship to the Contractor, the Contractor may terminate the Contract. Contractor's termination due to a postponement beyond this three-month period shall be by written notice to District within **TEN (10)** calendar days after receipt by Contractor of District's notice of postponement.
 - c. It is further understood by the Contractor that in the event that Contractor terminates the Contract as a result of postponement by the District, the District shall only be obligated to pay Contractor for the Work that Contractor had performed at the time of notification of postponement and which the District had in writing authorized Contractor to perform prior to issuing a Notice to Proceed.
 - d. Should the Contractor terminate the Contract as a result of a notice of postponement, District shall have the authority to award the Contract to the next lowest responsive responsible bidder.
41. The Bidder to whom Contract is awarded shall execute and submit the following documents by 5:00 p.m. of the **SEVENTH (7th)** calendar day following the date of the Notice of Award. Failure to properly and timely submit these documents entitles District to reject the bid as non-responsive.
- a. Agreement: To be executed by successful Bidder. Submit four (4) copies, each bearing an original signature.
 - b. Escrow of Bid Documentation: This must include all required documentation. See the document Escrow of Bid Documentation for more information.
 - c. Performance Bond (100%): On the form provided in the Contract Documents and fully executed as indicated on the form.
 - d. Payment Bond (100%) (Contractor's Labor and Material Bond): On the form provided in the Contract Documents and fully executed as indicated on the form.
 - e. Insurance Certificates and Endorsements as required.
 - f. Workers' Compensation Certification.
 - g. Prevailing Wage and Related Labor Requirements Certification.
 - h. Drug-Free Workplace Certification.
 - i. Tobacco-Free Environment Certification.
 - j. Hazardous Materials Certification.

- k. Imported Materials Certification. **[IF APPLICABLE]**
 - l. Criminal Background Investigation/Fingerprinting Certification.
42. Any bid protest by any Bidder regarding any other bid must be submitted in writing to the District, before 5:00 p.m. of the **THIRD (3rd)** business day following bid opening.
- a. Only a Bidder who has actually submitted a bid, and who could be awarded the Contract if the bid protest is upheld, is eligible to submit a bid protest. Subcontractors are not eligible to submit bid protests. A Bidder may not rely on the bid protest submitted by another Bidder.
 - b. A bid protest must contain a complete statement of any and all bases for the protest and all supporting documentation. Materials submitted after the bid protest deadline will not be considered.
 - c. The protest must refer to the specific portions of all documents that form the basis for the protest.
 - (1) Without limitation to other bases for protest, an inadvertent error in listing the California contractor license number on the Designated Subcontractors List shall not be grounds for filing a bid protest or grounds for considering the bid nonresponsive if the correct contractor's license number is submitted to the District within 24 hours after the bid opening and the corrected number corresponds with the submitted name and location for that subcontractor.
 - (2) Without limitation to other bases for protest, an inadvertent error listing an unregistered subcontractor shall not be grounds for filing a bid protest or grounds for considering the bid nonresponsive provided that any of the following apply:
 - (a) The subcontractor is registered prior to the bid opening.
 - (b) The subcontractor is registered and has paid the penalty registration fee within 24 hours after the bid opening.
 - (c) The subcontractor is replaced by another registered subcontractor pursuant to Public Contract Code section 4107.
 - d. The protest must include the name, address and telephone number of the person representing the protesting party.
 - e. The party filing the protest must concurrently transmit a copy of the protest and any attached documentation to all other parties with a direct financial interest that may be adversely affected by the outcome of the protest. Such parties shall include all other bidders or proposers who appear to have a reasonable prospect of receiving an award depending upon the outcome of the protest.
 - f. The procedure and time limits set forth in this paragraph are mandatory and are each bidder's sole and exclusive remedy in the event of bid protest. Failure to comply with these procedures shall constitute a waiver of any right to further pursue the bid protest, including filing a Government Code Claim or legal proceedings.
43. District reserves the right to reject any or all bids, including without limitation the right to reject any or all nonconforming, non-responsive, unbalanced, or conditional bids, to re-bid, and to reject the bid of any bidder if District believes that it would not be in the best interest of the District to make an award to that bidder, whether because the bid is not responsive or

the bidder is unqualified or of doubtful financial ability or fails to meet any other pertinent standard or criteria established by District. District also reserves the right to waive inconsequential deviations not involving price, time, or changes in the Work. For purposes of this paragraph, an "unbalanced bid" is one having nominal prices for some work items and/or enhanced prices for other work items.

44. Discrepancies between written words and figures, or words and numerals, will be resolved in favor of numerals or figures.
45. Prior to the award of Contract, District reserves the right to consider the responsibility of the Bidder. District may conduct investigations as District deems necessary to assist in the evaluation of any bid and to establish the responsibility, including, without limitation, qualifications and financial ability of Bidders, proposed subcontractors, suppliers, and other persons and organizations to perform and furnish the Work in accordance with the Contract Documents to District's satisfaction within the prescribed time.

END OF DOCUMENT

BIDDER INFORMATION AND FORMS**DETERMINATION OF BIDDER RESPONSIBILITY QUESTIONNAIRE**

The Public Contract Code requires that school districts, in certain circumstances, bid and award public contracts to the lowest *responsive* and *responsible* bidder. California law establishes a very comprehensive standard concerning bidder responsibility, such that a school agency has wide discretion and broad authority to make its determination of bidder responsibility on a case-by-case basis. Such authority empowers the District to conduct its own investigation, and make an assessment of the facts and circumstances to ascertain the quality, fitness, capacity and trustworthiness of each bidder. It is the purpose of this questionnaire to assist in determining contractor responsibility, and to aid the District in selecting the lowest responsible bidder (when the District does not opt to reject all bids).

Bidders must have completed the questionnaire, truthfully and completely, at least once since **January 1, 2015** to be considered for award on this project. If you completed this questionnaire since that date, you must certify that the data previously submitted is still true and accurate. Bidders must either complete the entire questionnaire or certify the previously submitted data as still current, truthful, and accurate, to be determined responsible and responsive to the bid announcement.

Bidders must answer all questions and provide all requested information, where applicable. If the answer to any question is "none", or is not applicable, please so state in writing. The District will evaluate bidders not only on the information contained in this questionnaire, but also using any and all information available through other sources, including District records, staff or representatives, interviews, and/or reference checks. Based on a complete evaluation, the awarding authority has sole and discretionary judgment to determine if the bidder is deemed responsible and/or qualified to perform the work. Bidders discovered to have omitted required information or provided false, misleading, or substantively incorrect statements, as determined solely by the District, will be disqualified from bidding. The District reserves the right to waive minor irregularities and to make all final determinations regarding prospective bidders' responsibility, fitness, and/or qualifications.

1. Experience: Describe three (3) public works or school district projects that your firm completed within the last three years, either as a Prime or Subcontractor, where your scope of work was similar in building size, scope, contract value and complexity to the proposed project.

A. Project Name: _____

Location: _____ Date completed: _____

Project Description (Scope of work, similarities to current advertised project):

Owner's Representative Name: _____ Ph number: _____

Construction Manager Name: _____ Ph number: _____

General Contractor Name _____ Ph number: _____

(If you were a Subcontractor):

Name of Architect: _____ Number of RFIs _____

Your base contract amount: \$ _____ Final contract amount : \$ _____

Explain difference from Base Contract amount, if any. _____

Initial contract time: _____ days Time extensions: _____ days

Days past contract completion date (excl. authorized time extensions): _____ days

B. Project Name: _____

Location: _____ Date completed: _____

Project Description (Scope of work, similarities to current advertised project):

Owner's Representative Name: _____ Ph number: _____

Construction Manager Name: _____ Ph number: _____

General Contractor Name _____ Ph number: _____

(If you were a Subcontractor):

Name of Architect: _____ Number of RFIs _____

Your base contract amount: \$ _____ Final contract amount : \$ _____

Explain difference from Base Contract amount, if any. _____

Initial contract time: _____ days Time extensions: _____ days

Days past contract completion date (excl. authorized time extensions): _____ days

C. Project Name: _____

Location: _____ Date completed: _____

Project Description (Scope of work, similarities to current advertised project):

Owner's Representative Name: _____ Ph number: _____

Construction Manager Name: _____ Ph number: _____

General Contractor Name _____ Ph number: _____

(If you were a Subcontractor):

Name of Architect: _____ Number of RFIs _____

Your base contract amount: \$ _____ Final contract amount : \$ _____

Explain difference from Base Contract amount, if any. _____

Initial contract time: _____ days Time extensions: _____ days

Days past contract completion date (excl. authorized time extensions): _____ days

2. Financial Data: Complete the table below using data from your most recent completed accounting fiscal year and most recent completed accounting fiscal quarter. (Bidder may be required to submit a financial statement upon request.).

Financial Ratios	Ratio Calculation	Previous Fiscal Year	Ratio 1	Most Recent Quarter	Ratio 2
Current Ratio	Current Assets	a	a / b	e	e / f
	Current Liabilities	b		f	

Debt Ratio	Total Debt	c		g	
	Total Net Worth	d	c / d	h	g / h

3. Licensing: Your License Number: _____ (Bidder must be a licensed contractor in California for the appropriate classification for the project being advertised.)

a. Has your license ever been revoked or suspended?

YES NO If yes, please explain (include dates, alleged misconduct, findings, and terms of the revocation or suspension).

b. Has a complaint ever been filed with the Contractor's State License Board against your company that required a formal hearing or inquiry?

YES NO If yes, provide explanation

c. Have you ever been licensed in California under a different name or license number?

YES NO If yes, provide name and/or license number.

Was that license ever revoked or suspended?

YES NO If yes, provide explanation

4. Safety: Has Cal OSHA, Federal OSHA, the EPA or any Air Quality Management District cited your firm in the past three (3) years?

YES NO If yes, attach a copy and description of each citation.

5. Arbitration and Litigation History: Has your firm had any claims, litigation, or disputes ending in mediation or arbitration, or termination for cause associated with any project (either by your company or against your company) in the past five (5) years?

YES NO If yes, attach a description of each instance including details of total claim amount, settlement amount and owner's name and phone number.

6. Prior Disqualifications, Criminal Matters, and Related Civil Suits:

- a. Has your firm ever been disqualified from performing work for the Sacramento City Unified School District?

YES NO If yes, provide the following information:

Project name: _____

Date of disqualification: _____

Duration of disqualification: _____

Reason for disqualification: _____

- b. Has your firm ever been disqualified from performing work for any contracting entity other than the Sacramento City Unified School District:

YES NO If yes, provide the following information:

Contracting Entity Name: _____

Date of disqualification: _____

Duration of disqualification: _____

Reason for disqualification: _____

- c. Has your firm or any of its owners, officers or partners ever been found liable in a civil suit or found guilty in a criminal action for making any false claim or material misrepresentation to any public agency or entity?

YES NO If "yes," explain who was involved, the name of the public agency, the date of the investigation and the grounds for the finding.

- d. Has your firm or any of its owners, officers or partners ever been convicted of a crime involving any federal, state, or local law related to construction work, fraud, theft, or other act of dishonesty?

YES NO If "yes," explain who was involved, the name of the public agency, the date of the conviction and the grounds for the conviction.

Questionnaire Certification

The undersigned declares under penalty of perjury that all information submitted in this questionnaire is current, true and accurate, and that this declaration was executed by the undersigned on:

(Date)

(Name and Title) printed or typed

(Signature)

(Firm Name)

OR

Previously Submitted Questionnaire Certification (Questionnaires completed prior to January 1, 2015 are no longer valid)

The undersigned declares under penalty of perjury that all information previously submitted to the District remains to be complete, true, and correct, and that this declaration was executed by the undersigned on:

(Date)

(Name and Title) printed or typed

(Signature)

(Firm Name)

END OF DOCUMENT

EXISTING CONDITIONS

46. Summary

This document describes existing conditions at or near the Project, and use of information available regarding existing conditions. This document is **not** part of the Contract Documents. See General Conditions for definition(s) of terms used herein.

47. Reports and Information on Existing Conditions

- a. Documents providing a general description of the Site and conditions of the Work may have been collected by Sacramento City Unified School District ("District"), its consultants, contractors, and tenants. These documents may include previous contracts, contract specifications, tenant improvement contracts, as-built drawings, utility drawings, and information regarding underground facilities.
- b. Information regarding existing conditions may be inspected at the District offices or the Construction Manager's offices, if any, and copies may be obtained at cost of reproduction and handling upon Bidder's agreement to pay for such copies. These reports, documents, and other information are **not** part of the Contract Documents.
- c. Information regarding existing conditions may also be included in the Project Manual, but shall **not** be considered part of the Contract Documents.
- d. Prior to commencing this Work, Contractor and the District's representative shall survey the Site to document the condition of the Site. Contractor will record the survey in digital videotape format and provide an electronic copy to the District within fourteen (14) days of the survey.
- e. Contractor may also document any pre-existing conditions in writing, provided that both the Contractor and the District's representative agree on said conditions and sign a memorandum documenting the same.
- f. The reports and other data or information regarding existing conditions and underground facilities at or contiguous to the Project are the following:
 - (1) Original Construction Drawings.
 - (2) Survey of Site.
 - (3) Hazardous Material Reports

48. Use of Information

- a. Information regarding existing conditions was obtained only for use of District and its consultants, contractors, and tenants for planning and design and is **not** part of the Contract Documents.
- b. District does not warrant, and makes no representation regarding, the accuracy or thoroughness of any information regarding existing conditions. Bidder represents and agrees that in submitting a bid it is not relying on any information regarding existing conditions supplied by District.
- c. Under no circumstances shall District be deemed to warrant or represent existing above-ground conditions, as-built conditions, or other actual conditions, verifiable by independent investigation. These conditions are verifiable by Contractor by the

performance of its own independent investigation that Contractor must perform as a condition to bidding and Contractor should not and shall not rely on this information or any other information supplied by District regarding existing conditions.

- d. Any information shown or indicated in the reports and other data supplied herein with respect to existing underground facilities at or contiguous to the Project may be based upon information and data furnished to District by the District's employees and/or consultants or builders of such underground facilities or others. District does not assume responsibility for the completeness of this information, and Bidder is solely responsible for any interpretation or conclusion drawn from this information.
- e. District shall be responsible only for the general accuracy of information regarding underground facilities, and only for those underground facilities that are owned by District, and only where Bidder has conducted the independent investigation required of it pursuant to the Instructions to Bidders, and discrepancies are not apparent.

49. Investigations/Site Examinations

- a. Before submitting a Bid, each Bidder is responsible for conducting or obtaining any additional or supplementary examinations, investigations, explorations, tests, studies, and data concerning conditions (surface, subsurface, and underground facilities) at or contiguous to the Site or otherwise, that may affect cost, progress, performance, or furnishing of Work or that relate to any aspect of the means, methods, techniques, sequences, or procedures of construction to be employed by Bidder and safety precautions and programs incident thereto or that Bidder deems necessary to determine its Bid for performing and furnishing the Work in accordance with the time, price, and other terms and conditions of Contract Documents.
- b. On request, District will provide each Bidder access to the Site to conduct such examinations, investigations, explorations, tests, and studies, as each Bidder deems necessary for submission of a Bid. Bidders must fill all holes and clean up and restore the Site to its former condition upon completion of its explorations, investigations, tests, and studies. Such investigations and Site examinations may be performed during any and all Site visits indicated in the Notice to Bidders and only under the provisions of the Contract Documents, including, but not limited to, proof of insurance and obligation to indemnify against claims arising from such work, and District's prior approval.

END OF DOCUMENT

GEOTECHNICAL DATA

50. Summary

This document describes geotechnical data at or near the Project that is in the District's possession available for Contractor's review, and use of data resulting from various investigations. This document is **not** part of the Contract Documents. See General Conditions for definition(s) of terms used herein.

51. Geotechnical Reports

- a. Geotechnical reports may have been prepared for and around the Site by soil investigation engineers hired by Sacramento City Unified School District ("District"), and its consultants, contractors, and tenants.
- b. Geotechnical reports may be inspected at the District offices or the Construction Manager's offices, if any, and copies may be obtained at cost of reproduction and handling upon Bidder's agreement to pay for such copies. These reports are **not** part of the Contract Documents.

52. Use of Data

- a. Geotechnical data were obtained only for use of District and its consultants, contractors, and tenants for planning and design and are **not** a part of Contract Documents.
- b. Except as expressly set forth below, District does not warrant, and makes no representation regarding, the accuracy or thoroughness of any geotechnical data. Bidder represents and agrees that in submitting a Bid it is not relying on any geotechnical data supplied by District, except as specifically allowed below.
- c. Under no circumstances shall District be deemed to make a warranty or representation of existing above ground conditions, as-built conditions, or other actual conditions verifiable by independent investigation. These conditions are verifiable by Contractor by the performance of its own independent investigation that Contractor should perform as a condition to bidding and Contractor must not and shall not rely on information supplied by District.

Limited Reliance Site that have been utilized by District in preparation of the Contract Documents.

Drawings of physical conditions in or relating to existing subsurface structures (except underground facilities) that are at or contiguous to the Site and have been utilized by District in preparation of the Contract Documents.

- d. Bidder may rely upon the general accuracy of the "technical data" contained in the reports and drawings identified above, but only insofar as it relates to subsurface conditions, provided Bidder has conducted the independent investigation required pursuant to Instructions to Bidders, and discrepancies are not apparent. The term "technical data" in the referenced reports and drawings shall be limited as follows:
 - (1) The term "technical data" shall include actual reported depths, reported quantities, reported soil types, reported soil conditions, and reported material, equipment or structures that were encountered during subsurface exploration.

The term "technical data" does not include, and Bidder may not rely upon, any other data, interpretations, opinions or information shown or indicated in such drawings or reports that otherwise relate to subsurface conditions or described structures.

- (2) The term "technical data" shall not include the location of underground facilities.
- (3) Bidder may not rely on the completeness of reports and drawings for the purposes of bidding or construction. Bidder may rely upon the general accuracy of the "technical data" contained in such reports or drawings.
- (4) Bidder is solely responsible for any interpretation or conclusion drawn from any "technical data" or any other data, interpretations, opinions, or information provided in the identified reports and drawings.

53. Investigations/Site Examinations

- a. Before submitting a Bid, each Bidder is responsible for conducting or obtaining any additional or supplementary examinations, investigations, explorations, tests, studies, and data concerning conditions (surface, subsurface, and underground facilities) at or contiguous to the Site or otherwise, that may affect cost, progress, performance, or furnishing of Work or that relate to any aspect of the means, methods, techniques, sequences, or procedures of construction to be employed by Bidder and safety precautions and programs incident thereto or that Bidder deems necessary to determine its Bid for performing and furnishing the Work in accordance with the time, price, and other terms and conditions of Contract Documents.
- b. On request, District will provide each Bidder access to the Site to conduct such examinations, investigations, explorations, tests, and studies, as each Bidder deems necessary for submission of a Bid. Bidders must fill all holes and clean up and restore the Site to its former condition upon completion of its explorations, investigations, tests, and studies. Such investigations and Site examinations may be performed during any and all Site visits indicated in the Notice to Bidders and only under the provisions of the Contract Documents, including, but not limited to, proof of insurance and obligation to indemnify against claims arising from such work, and District's prior approval.

END OF DOCUMENT

BID FORM AND PROPOSAL

Sacramento City Unified School District ("District" or "Owner")

From: _____
(Proper Name of Bidder)

ACKNOWLEDGEMENT OF GENERAL CONDITIONS

The General Conditions and definitions therein are accessible on the SCUSD website at <http://www.scusd.edu/contracts-department>, and are an integral part of the Contract Documents. The Contractor shall not disclaim knowledge of the meaning and effect of any term or provision of these General Conditions, and Supplemental Conditions, if any, and agrees to strictly abide by their meaning and intent. In the event the Contractor fails to initial this acknowledgement, the District shall have the right to reject the Bid.

CONTRACTOR'S INITIALS: _____

The undersigned declares that the Contract Documents including, without limitation, the Notice to Bidders and the Instructions to Bidders have been read and agrees and proposes to furnish all necessary labor, materials, tools, transportation, services and equipment to perform and furnish all work in accordance with the terms and conditions of the Contract Documents, including, without limitation, the Drawings and Specifications of Bid No. 0525-402,

PROJECT: Outdoor Learning Area and Landscaping at John F. Kennedy High School

and will accept in full payment for that Work the following total lump sum amount, all taxes included:

A.	_____ Dollars	\$ _____
	BASE BID	
B.	_____ Dollars	\$ _____
	ALLOWANCE	
C.	_____ Dollars	\$ _____
	TOTAL BID	

54. **Allowance.** The Bidder's Bid shall include a ten percent (10%) allowance for unforeseen items.

The above allowance shall only be allocated for unforeseen items relating to the Work. Contractor shall not bill for or be due any portion of this allowance unless the District has

identified specific work, Contractor has submitted a price for that work or the District has proposed a price for that work, the District has accepted the cost for that work, and the District has prepared a change order incorporating that work. Contractor hereby authorizes the District to execute a unilateral deductive change order at or near the end of the Project for all or any portion of the allowance not allocated.

- 55. The undersigned has reviewed the Work outlined in the Contract Documents and fully understands the scope of Work required in this Proposal, understands the construction and project management function(s) is described in the Contract Documents, and that each Bidder who is awarded a contract shall be in fact a prime contractor, not a subcontractor, to the District, and agrees that its Proposal, if accepted by the District, will be the basis for the Bidder to enter into a contract with the District in accordance with the intent of the Contract Documents.
- 56. The undersigned has notified the District in writing of any discrepancies or omissions or of any doubt, questions, or ambiguities about the meaning of any of the Contract Documents, and has contacted the Construction Manager before bid date to verify the issuance of any clarifying Addenda.
- 57. The undersigned agrees to commence work under this Contract on the date established in the Contract Documents and to complete all work within the time specified in the Contract Documents.
- 58. The liquidated damages clause of the General Conditions and Agreement is hereby acknowledged.
- 59. It is understood that the District reserves the right to reject this bid and that the bid shall remain open to acceptance and is irrevocable for a period of ninety (90) days.
- 60. The following documents are attached hereto:
 - Bid Bond on the District's form or other security
 - Designated Subcontractors List
 - Site-Visit Certification
 - Non-Collusion Declaration

Receipt and acceptance of the following addenda is hereby acknowledged:

No. _____, Dated _____	No. _____, Dated _____
------------------------	------------------------

- 61. Bidder acknowledges that the license required for performance of the Work is a B-General Building; or C-27, Landscaping license.
- 62. The undersigned hereby certifies that Bidder is able to furnish labor that can work in harmony with all other elements of labor employed or to be employed on the Work.
- 63. Bidder specifically acknowledges and understands that if it is awarded the Contract, that it shall perform the Work of the Project while complying with all requirements of the Department of Industrial Relations [and with all requirements of the Project Labor Agreement].
- 64. The Bidder represents that it is competent, knowledgeable, and has special skills with respect to the nature, extent, and inherent conditions of the Work to be performed. Bidder further acknowledges that there are certain peculiar and inherent conditions existent in the

construction of the Work that may create, during the Work, unusual or peculiar unsafe conditions hazardous to persons and property.

- 65. Bidder expressly acknowledges that it is aware of such peculiar risks and that it has the skill and experience to foresee and to adopt protective measures to adequately and safely perform the Work with respect to such hazards.
- 66. Bidder expressly acknowledges that it is aware that if a false claim is knowingly submitted (as the terms "claim" and "knowingly" are defined in the California False Claims Act, Cal. Gov. Code, §12650 et seq.), the District will be entitled to civil remedies set forth in the California False Claim Act. It may also be considered fraud and the Contractor may be subject to criminal prosecution.
- 67. The undersigned Bidder certifies that it is, at the time of bidding, and shall be throughout the period of the contract, licensed by the State of California to do the type of work required under the terms of the Contract Documents and registered as a public works contractor with the Department of Industrial Relations. Bidder further certifies that it is regularly engaged in the general class and type of work called for in the Contract Documents.

Furthermore, Bidder hereby certifies to the District that all representations, certifications, and statements made by Bidder, as set forth in this bid form, are true and correct and are made under penalty of perjury.

Dated this _____ day of _____, 2016

Name of Bidder _____

Type of Organization _____

Signed by _____

Title of Signer _____

Address of Bidder _____

Taxpayer's Identification No. of Bidder _____

Telephone Number _____

Fax Number _____

E-mail _____ Web page _____

Contractor's License No(s): No.: _____ Class: _____ Expiration Date: _____

No.: _____ Class: _____ Expiration Date: _____

No.: _____ Class: _____ Expiration Date: _____

Public Works Contractor Registration No.: _____

If Bidder is a corporation, affix corporate seal.

Name of Corporation: _____

President: _____

Secretary: _____

Treasurer: _____

Manager: _____

END OF DOCUMENT

BID BOND

(Note: If Bidder is providing a bid bond as its bid security, Bidder must use this form, NOT a surety company form.)

KNOW ALL PERSONS BY THESE PRESENTS:

That the undersigned, as _____ as Principal ("Principal"), and _____ as Surety ("Surety"), are held and firmly bound unto the Sacramento City Unified School District ("District") of _____ County, State of California as Obligee, in the sum of:

_____ Dollars (\$ _____)

lawful money of the United States of America, for the payment of which sum well and truly to be made, we, and each of us, bind ourselves, our heirs, executors, administrators, successors, and assigns, jointly and severally, firmly by these presents.

THE CONDITION OF THIS OBLIGATION IS SUCH that whereas the Principal has submitted a bid to the District for all Work specifically described in the accompanying bid;

NOW, THEREFORE, if the Principal is awarded the Contract and, within the time and manner required under the Contract Documents, after the prescribed forms are presented to Principal for signature, enters into a written contract, in the prescribed form in accordance with the bid, and files two bonds, one guaranteeing faithful performance and the other guaranteeing payment for labor and materials as required by law, and meets all other conditions to the contract between the Principal and the Obligee becoming effective, or if the Principal shall fully reimburse and save harmless the Obligee from any damage sustained by the Obligee through failure of the Principal to enter into the written contract and to file the required performance and labor and material bonds, and to meet all other conditions to the Contract between the Principal and the Obligee becoming effective, then this obligation shall be null and void; otherwise, it shall be and remain in full force and effect. The full payment of the sum stated above shall be due immediately if Principal fails to execute the Contract within seven (7) days of the date of the District's Notice of Award to Principal.

Surety, for value received, hereby stipulates and agrees that no change, extension of time, alteration or addition to the terms of the Contract or the call for bids, or to the work to be performed thereunder, or the specifications accompanying the same, shall in any way affect its obligation under this bond, and it does hereby waive notice of any such change, extension of time, alteration or addition to the terms of the Contract or the call for bids, or to the work, or to the specifications.

In the event suit is brought upon this bond by the Obligee and judgment is recovered, the Surety shall pay all costs incurred by the Obligee in such suit, including a reasonable attorneys' fee to be fixed by the Court.

If the District awards the bid, the security of unsuccessful bidder(s) shall be returned within sixty (60) days from the time the award is made. Unless otherwise required by law, no bidder may withdraw its bid for ninety (90) days after the date of the bid opening.

IN WITNESS WHEREOF, this instrument has been duly executed by the Principal and Surety above named, on the _____ day of _____, 2016.

(Affix Corporate Seal)

Principal

By

(Affix Corporate Seal)

Surety

By

Name of California Agent of Surety

Address of California Agent of Surety

Telephone Number of California Agent of Surety

Bidder must attach Power of Attorney and Certificate of Authority for Surety and a Notarial Acknowledgment for all Surety's signatures. The California Department of Insurance must authorize the Surety to be an admitted Surety Insurer.

END OF DOCUMENT

DESIGNATED SUBCONTRACTORS LIST
(TO BE EXECUTED BY BIDDER AND SUBMITTED WITH BID)

PROJECT: Outdoor Learning Area and Landscaping at John F. Kennedy High School

Bidder acknowledges and agrees that under Public Contract Code section 4100, et seq., it must clearly set forth below the name, location and California contractor license number of each subcontractor who will perform work or labor or render service to the Bidder in or about the construction of the Work or who will specially fabricate and install a portion of the Work according to detailed drawings contained in the plans and specifications in an amount in excess of one-half of one percent (0.5%) of Bidder's total Bid and the kind of Work that each will perform. Vendors or suppliers of materials only do not need to be listed.

Bidder acknowledges and agrees that under Public Contract Code section 4100, et seq., if Bidder fails to list as to any portion of Work, or if Bidder lists more than one subcontractor to perform the same portion of Work, Bidder must perform that portion itself or be subjected to penalty under applicable law. In case more than one subcontractor is named for the same kind of Work, state the portion of the kind of Work that each subcontractor will perform.

If alternate bids are called for and Bidder intends to use subcontractors different from or in addition to those subcontractors listed for work under the base Bid, Bidder must list subcontractors that will perform Work in an amount in excess of one half of one percent (0.5%) of Bidder's total Bid, including alternates.

If further space is required for the list of proposed subcontractors, attach additional sheets showing the required information, as indicated below.

Subcontractor Name: _____

CA Cont. Lic. #: _____ Location: _____

Portion of Work: _____

Subcontractor Name: _____

CA Cont. Lic. #: _____ Location: _____

Portion of Work: _____

Subcontractor Name: _____

CA Cont. Lic. #: _____ Location: _____

Portion of Work: _____

Subcontractor Name: _____

CA Cont. Lic. #: _____ Location: _____

Portion of Work: _____

Subcontractor Name: _____

CA Cont. Lic. #: _____ Location: _____

Portion of Work: _____

Subcontractor Name: _____

CA Cont. Lic. #: _____ Location: _____

Portion of Work: _____

Subcontractor Name: _____

CA Cont. Lic. #: _____ Location: _____

Portion of Work: _____

Subcontractor Name: _____

CA Cont. Lic. #: _____ Location: _____

Portion of Work: _____

Date: _____

Proper Name of Bidder: _____

Signature: _____

Print Name: _____

Title: _____

END OF DOCUMENT

SITE VISIT CERTIFICATION

TO BE EXECUTED BY BIDDER AND SUBMITTED WITH BID
IF SITE VISIT WAS MANDATORY

PROJECT: Outdoor Learning Area and Landscaping at John F. Kennedy High School

Check option that applies:

_____ I certify that I visited the Site of the proposed Work and became fully acquainted with the conditions relating to construction and labor. I fully understand the facilities, difficulties, and restrictions attending the execution of the Work under contract.

_____ I certify that _____ (Bidder's representative) visited the Site of the proposed Work and became fully acquainted with the conditions relating to construction and labor. The Bidder's representative fully understood the facilities, difficulties, and restrictions attending the execution of the Work under contract.

Bidder fully indemnifies the Sacramento City Unified School District, its Architect, its Engineer, its Construction Manager, and all of their respective officers, agents, employees, and consultants from any damage, or omissions, related to conditions that could have been identified during my visit and/or the Bidder's representative's visit to the Site.

I certify under penalty of perjury under the laws of the State of California that the foregoing is true and correct.

Date: _____

Proper Name of Bidder: _____

Signature: _____

Print Name: _____

Title: _____

END OF DOCUMENT

**NON-COLLUSION DECLARATION
TO BE EXECUTED BY BIDDER AND SUBMITTED WITH BID
Public Contract Code Section 7106**

The undersigned declares:

I am the _____ of _____, the party making the foregoing bid.

The bid is not made in the interest of, or on behalf of, any undisclosed person, partnership, company, association, organization, or corporation. The bid is genuine and not collusive or sham. The bidder has not directly or indirectly induced or solicited any other bidder to put in a false or sham bid. The bidder has not directly or indirectly colluded, conspired, connived, or agreed with any bidder or anyone else to put in a sham bid, or to refrain from bidding. The bidder has not in any manner, directly or indirectly, sought by agreement, communication, or conference with anyone to fix the bid price of the bidder or any other bidder, or to fix any overhead, profit, or cost element of the bid price, or of that of any other bidder. All statements contained in the bid are true. The bidder has not, directly or indirectly, submitted his or her bid price or any breakdown thereof, or the contents thereof, or divulged information or data relative thereto, to any corporation, partnership, company, association, organization, bid depository, or to any member or agent thereof, to effectuate a collusive or sham bid, and has not paid, and will not pay, any person or entity for such purpose.

Any person executing this declaration on behalf of a bidder that is a corporation, partnership, joint venture, limited liability company, limited liability partnership, or any other entity, hereby represents that he or she has full power to execute, and does execute, this declaration on behalf of the bidder.

I declare under penalty of perjury under the laws of the State of California that the foregoing is true and correct and that this declaration is executed on _____, at _____, _____.

Proper Name of Bidder: _____

Signature: _____

Print Name: _____

Title: _____

END OF DOCUMENT

GREAT VALLEY DESIGN, INC.

LANDSCAPE ARCHITECTURE

LAND PLANNING

SITE MANAGEMENT

1218 SPRUCE LAKE

BOULDER, CO 80501

(303) 782-1058

OWNER:

SARGENT & Lundy

SCHOOL DISTRICT

PROJECT SITE:
JRF HIGH SCHOOL
MADISON DRIVE
SARGENT & LUNDY
SCHOOL DISTRICT

— EXISTING LANDSCAPE —

POINT OF BEGINNING:
END OF EXISTING FENCE

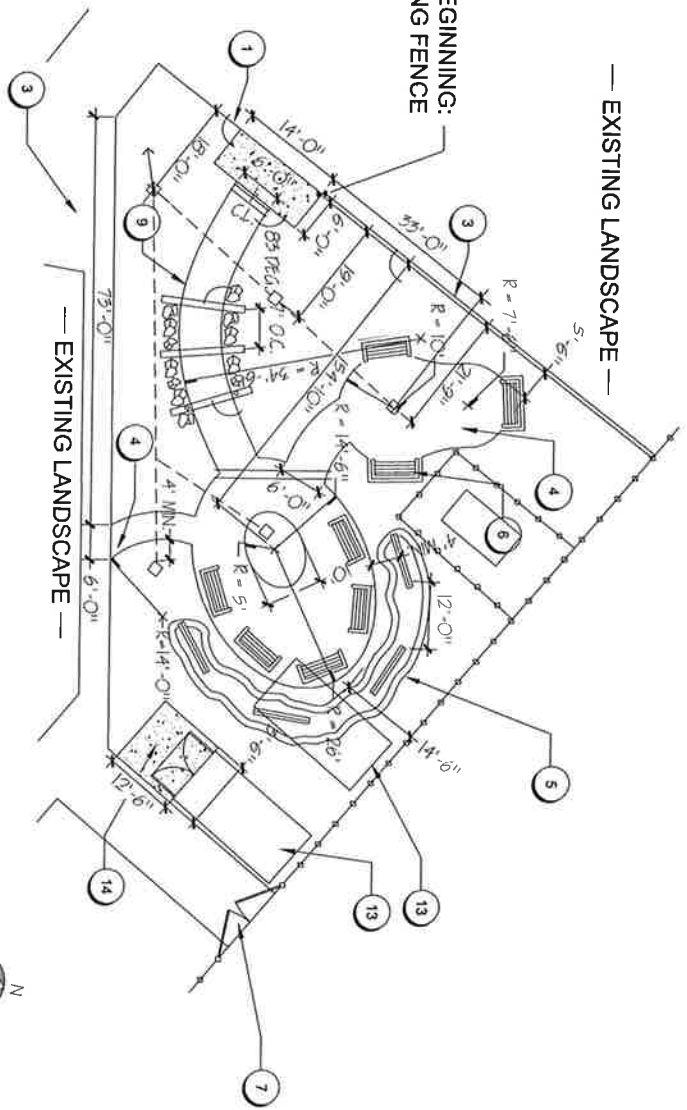

LAYOUT NOTES

1. ALL ANGLES NOT SHOWN ARE 45 OR 90 DEGREES.
 2. ADJUST LAYOUT ONLY WITH APPROVAL OF SCUSC REPRESENTATIVE.
 3. EXISTING PAVING AND FENCING TO REMAIN, PROTECT
 4. TRAILS AND PAVING SHOWN WITH MAX. SETBACKS, ACTUAL LAYOUT PER SCUSC REPRESENTATIVE
 5. MOUND LOCATION SHOWN WITH MAX. SETBACKS, ACTUAL LAYOUT PER SCUSC REPRESENTATIVE
 6. FURNITURE AND WALK LAYOUT TO MEET A.D.A. GUIDELINES
 7. EXISTING EQUIPMENT ACCESS AND GATE AT CHAINLINK FENCE
 8. LOCATIONS OF UTILITIES AND EXISTING FEATURES SHOWN ARE APPROXIMATE, CONTRACTOR TO VERIFY LOCATIONS.
 9. ALL RADII AND CURVES ARE TO BE CONTINUOUS WITH SMOOTH TRANSITIONS, WITHOUT ABRUPT CHANGES OR BENDS.
 10. ALL FORMS AND ALIGNMENT SHALL BE INSPECTED PRIOR TO CONSTRUCTION BY SCUSC REPRESENTATIVE
 11. ANY SITE DIMENSION OR LAYOUT DISCREPANCIES SHALL BE BROUGHT TO THE ATTENTION OF G.V.D.
 12. DRAWINGS REPRESENT FINISHED STRUCTURES, ALL BRACKING, TEMPORARY SUPPORTS, SHORING, SECURITY FENCING, ETC., IS THE RESPONSIBILITY OF THE CONTRACTOR.
 13. EXISTING CONTAINER, RELOCATE TO NEW LOCATION AS SHOWN AND REPAIR GRADE AT ORIGINAL SITE.
 14. NEW CONCRETE, TYPICAL
- SEE SHEET L-2 FOR GRADING PLANS.
SEE SHEET L-3 FOR IRRIGATION PLANS.
SEE SHEET L-4 AND L-5 FOR IRRIGATION AND CONSTRUCTION DETAILS.



ARCHITECT'S STAMP:

PROJECT MANAGER
SCOTT MOBERG

SCALE:
1" = 10' - 0"

DATE:
MAY 4, 2018

REVISION:
CLIENT COMMENTS: 3.28.18
CLIENT COMMENTS: 3.22.18

SHEET NUMBER
L-1

LAYOUT PLAN

PROJECT GREEN
SITE IMPROVEMENTS

- 1 1/2" VINE FIBER FILLED EXPANSION JOINT W/ FINISH LAYER SEALANT AND 2" COMPACTED SUBGRADE
- 2 2" CONC. SLAB ON 2" SUBGRADE
- 3 2" CONC. SLAB ON 2" SUBGRADE
- 4 1/2" VINE FIBER FILLED EXPANSION JOINT W/ FINISH LAYER SEALANT AND 2" COMPACTED SUBGRADE
- 5 1/2" VINE FIBER FILLED EXPANSION JOINT W/ FINISH LAYER SEALANT AND 2" COMPACTED SUBGRADE
- 6 1/2" VINE FIBER FILLED EXPANSION JOINT W/ FINISH LAYER SEALANT AND 2" COMPACTED SUBGRADE

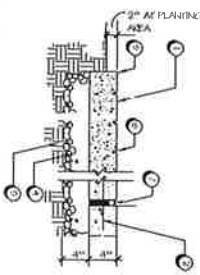

A CONCRETE PAVING
N.T.S.

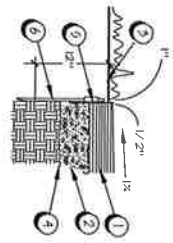

- 1 2" DECOMPOSED GRANITE PAVING
- 2 2" SUBGRADE
- 3 2" CURB
- 4 1/2" GAP
- 5 2" ALUMINUM FRAME LOCK

B D.G. PAVING AND MAINTENANCE EDGE
N.T.S.

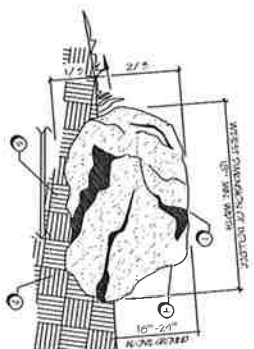

C BOULDER SEAT WALL
N.T.S.

- 1 BOULDER SEAT WALL
- 2 2" CURB
- 3 2" CURB
- 4 2" CURB
- 5 2" CURB
- 6 2" CURB

NOTE: ALL SOLIDERS SHALL BE SELECTED & PLACED LARGE END TO LARGE END. LANDSCAPE REPAIR TO BE MATCHED TO EXISTING.

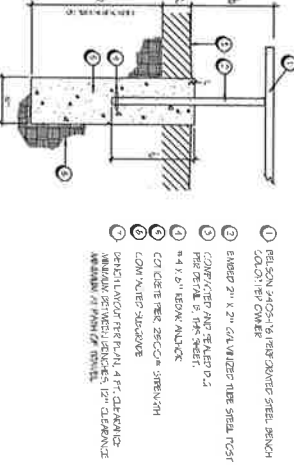

D PERFORATED STEEL BENCH
N.T.S.

- 1 1/2" PERFORATED STEEL BENCH
- 2 2" SUBGRADE
- 3 2" CURB
- 4 2" CURB
- 5 2" CURB
- 6 2" CURB

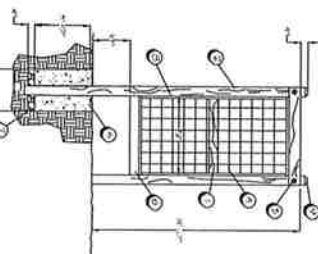

E FREE STANDING VINE TRELLIS
SCALE: 1/2" = 1'-0"

- 1 2" x 4" VINYL POST
- 2 2" x 4" VINYL POST
- 3 2" x 4" VINYL POST
- 4 2" x 4" VINYL POST
- 5 2" x 4" VINYL POST
- 6 2" x 4" VINYL POST

NOTES:
- ALL VINE TO BE PAWLED AIR
- ALL POSTS TO BE GALVANIZED
- ALL VINE TO BE PAWLED AIR

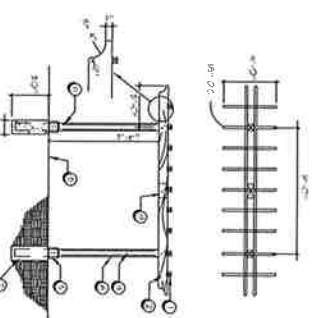

F TIMBER SHADE PERGOLA
SCALE: 1/4" = 1'-0"

- 1 2" x 4" VINYL POST
- 2 2" x 4" VINYL POST
- 3 2" x 4" VINYL POST
- 4 2" x 4" VINYL POST
- 5 2" x 4" VINYL POST
- 6 2" x 4" VINYL POST

NOTE:
- ALL VINE TO BE PAWLED AIR
- ALL POSTS TO BE GALVANIZED
- ALL VINE TO BE PAWLED AIR



ARCHITECTS STAMP:

PROJECT MANAGER
SCOTT YOUNGER

SCALE:
SEE DETAIL

DATE:
MAY 15, 2024

REVISION:
1

SHEET NUMBER
L-4

CONSTRUCTION DETAILS
OF 3

HABITAT GARDEN &
OUTDOOR CLASSROOM

GREAT VALLEY DESIGN, INC.

LANDSCAPE ARCHITECTURE
SHELDON W. WILSON

1234 STREET
DAVIS CA 95618
(916) 782-7898

OWNER:
SACRAMENTO CITY UNIFIED
SCHOOL DISTRICT

DATE: 05/15/2024
PROJECT: HABITAT GARDEN & OUTDOOR CLASSROOM
SHEET: L-4 OF 3

