



Business Services

Contracts Office

5735 47th Avenue • Sacramento, CA 95824

(916) 643-2464

Gerardo Castillo, Chief Business Officer

Kimberly Teague, Contract Specialist

ADDENDUM NO. 1

Date: April 13, 2016

Issued by: Sacramento City Unified School District

Project: AC Paving/Concrete Replacement at Ethel Phillips ES

You are hereby notified of the following changes, clarifications, or modifications to the original Contract Documents, Specifications, and Drawings. This Addendum shall supersede the original project documents, and shall take precedence over anything to the contrary therein. All Addenda shall be acknowledged in the Bid Form. Failure to do so may result in disqualification of the bid. All other conditions remain unchanged.

SPECIFICATIONS

ITEM # 1.1 Section 01 25 00 – Information for Alternate Proposals – Addendum # 1: Add the attached **Section 01 25 00 – Information for Alternate Proposals – Addendum # 1**, to the contract documents. **New Bid Form (page 24) is attached.**

ITEM # 1.2 Section 32 12 00 – Hot-Mixed Asphalt Paving – Item 2.11 – Wheel Stops: This item applies to Additive Alternate # 2 only. See attached detail **ADD1-A1** for additional information.

ITEM # 1.3 Section 32 31 13 – Chain Link Fencing and Gates, Item # 2.2.B.1: Add the following as Item a.:

- a. Size: 1-inch mesh, 7-gage “no climb” wire, located as shown on the attached revised Sheet **ADD1-A101**.

DRAWINGS

ITEM # 1.4 General: The set of plans previously in e-Builder included a reference to another ERP project at Ethel Phillips Elementary School. The correct set of plans is in the Bid Documents folder on e-Builder and is titled “EthelPhillipsES-ACPaving-PLANS”.

ITEM # 1.5 Sheet A100 – Site Demolition Plan:

- A. Change Note .13 to read: “CONTRACTOR SHALL BE RESPONSIBLE TO SALVAGE, REMOVE, AND RELOCATE STORAGE SHEDS DURING CONSTRUCTION, AND REINSTALL SHEDS IN THE SAME LOCATION PER DISTRICT REQUEST AFTER AC PAVING IS COMPLETE.”
- B. At the 12'-0" tall fence immediately next to the existing adjacent building, at the East end of the site, change the three Keyed Notes indicating .07 to indicate Keyed Note .19. This portion of the fence will be demolished completely, and will not be reinstalled. The 12'-0" tall fence should return and terminate at the neighboring building. See revised Sheet ADD-1 A101 for additional information.
- C. **ADD1-A2 – Partial Site Demolition Plan**, is a partial view of the site demolition plan, clarifying extensive demolition on the 12'-0" tall fence at the SE corner of the site. Please replace this portion of the site demolition plan with this partial plan view and associated keyed notes.

ITEM # 1.6 Sheet A101 – Paving Repair Plan: Replace this sheet with the attached Sheet **ADD1-A101**.

ITEM # 1.7 Detail ADD1-A1 – Wheel Stop Detail: Add attached detail **ADD1-A1** to the contract documents.

END OF ADDENDUM NO. 1

Attachments

SECTION 01 25 00 – INFORMATION FOR ALTERNATE PROPOSALS – ADDENDUM # 1

1.1 DESCRIPTION

1.1.1 Work included: Provide alternative bid proposal as described in this section:

**ADDITIVE ALTERNATE # 1: PARKING LOT STRIPING, AS SHOWN ON SHEET
ADD-1 A101.**

ADD _____ Dollars (\$_____.____)
(written amount)

**ADDITIVE ALTERNATE # 2: PRECAST WHEEL STOPS, AS SHOWN ON SHEET
ADD-1 A101.**

ADD _____ Dollars(\$_____.____)
(written amount)

1.1.2 Related work:

1.1.2.1 Documents affecting work of this Section include, but are not necessarily limited to, the Conditions of the Contract and Sections in Division 1 of these Specifications.

1.1.2.2 Extent: It is the responsibility of each Bidder to determine to his own satisfaction and for his own purposes the limits and extent of the work affected by each Alternate and to make full and proper allowance therefore in the submission of his Proposal. Where alternate details are furnished which relate to the Alternate Bid, the Bidder shall base his Alternate Bid on such details. Work required by Alternate Bids shall be performed in accordance with the Specifications of the trade sections affected.

1.1.3 Procedures:

1.1.3.1 Provide alternative proposals to be added to or deducted from the amount of the Base Bid if the corresponding change in scope is accepted by the DISTRICT.

1.1.3.2 Include within the alternative bid prices all costs, including labor, materials, installations, and fees.

1.1.3.3 Show the proposed alternative amounts opposite their proper description on the Contractor's Proposal.

1.1.4 Acceptance or Rejection:

1.1.4.1 Acceptance or rejection of Alternate Bids is subject to DISTRICT's discretion. The DISTRICT reserves the right to award any or none of the Alternate Proposal items as the DISTRICT may deem to be in its best interests and without regard to the order in which such items are listed in the Proposal.

END OF SECTION

Additive Alternates:

Additive Alternate #1

Dollars	\$ _____
PARKING LOT STRIPING, AS SHOWN ON SHEET ADD-1 A101	

Additive Alternate #2

Dollars	\$ _____
PRECAST WHEEL STOPS, AS SHOWN ON SHEET ADD1-A101	

Descriptions of alternates are primarily scope definitions and do not necessarily detail the full range of materials and processes needed to complete the construction.

- 55. The undersigned has reviewed the Work outlined in the Contract Documents and fully understands the scope of Work required in this Proposal, understands the construction and project management function(s) is described in the Contract Documents, and that each Bidder who is awarded a contract shall be in fact a prime contractor, not a subcontractor, to the District, and agrees that its Proposal, if accepted by the District, will be the basis for the Bidder to enter into a contract with the District in accordance with the intent of the Contract Documents.
- 56. The undersigned has notified the District in writing of any discrepancies or omissions or of any doubt, questions, or ambiguities about the meaning of any of the Contract Documents, and has contacted the Construction Manager before bid date to verify the issuance of any clarifying Addenda.
- 57. The undersigned agrees to commence work under this Contract on the date established in the Contract Documents and to complete all work within the time specified in the Contract Documents.
- 58. The liquidated damages clause of the General Conditions and Agreement is hereby acknowledged.
- 59. It is understood that the District reserves the right to reject this bid and that the bid shall remain open to acceptance and is irrevocable for a period of ninety (90) days.
- 60. The following documents are attached hereto:
 - Bid Bond on the District's form or other security
 - Designated Subcontractors List
 - Site-Visit Certification
 - Non-Collusion Declaration
- 61. Receipt and acceptance of the following addenda is hereby acknowledged:

No. _____, Dated _____	No. _____, Dated _____
------------------------	------------------------

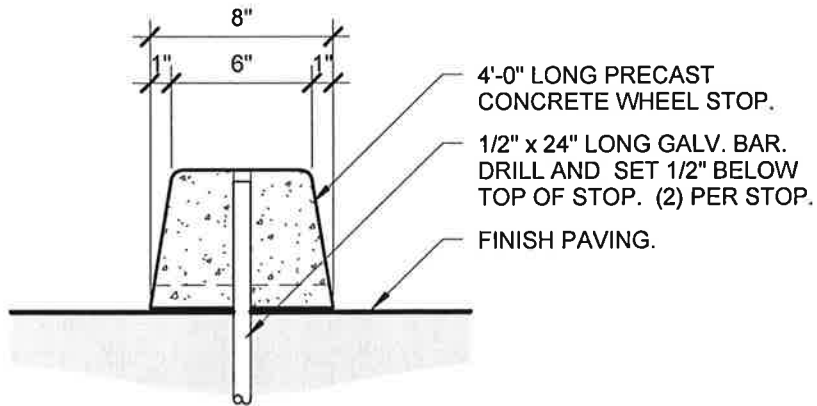

1 WHEEL STOP DETAIL
 1 1/2" = 1'-0"



CALIFORNIA DESIGN WEST ARCHITECTS INC.
 2100 19TH STREET, SACRAMENTO, CA 95818
 PHONE: (916) 446-2466 FAX: (916) 446-5118

ETHEL PHILLIPS ELEMENTARY SCHOOL
ERP PROJECTS
PAVING REPAIR
 SACRAMENTO CITY UNIFIED SCHOOL DISTRICT

DSA FILE NO:

DSA APPL. NO:

OPSC APPL. NO:

UNIT: SHT. OF SHTS.

JOB NO. - DATE:
 APR 12, 2016

DRAWN BY DRAWING NO:

CHECKED **ADD1-A1**

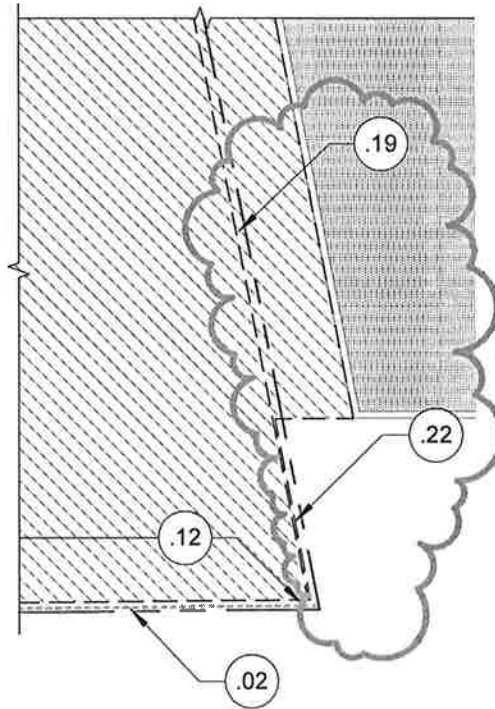

1 PARTIAL SITE DEMOLITION PLAN
 1/16" = 1'-0"

KEYED NOTES

- .19 DEMO (E) CHAIN LINK FENCING, INCLUDING ALL POSTS AND FOOTINGS. MAINTAIN END POST WHERE FENCE IS TO REMAIN / RECONNECT.
- .22 REMOVE CHAIN LINK FENCE FABRIC. FENCE POSTS AND FOOTINGS TO REMAIN.

DESIGN
California
WEST

CALIFORNIA DESIGN WEST ARCHITECTS INC.
 2100 19TH STREET, SACRAMENTO, CA 95818
 PHONE: (916) 446-2466 FAX: (916) 446-5118

ETHEL PHILLIPS ELEMENTARY SCHOOL
 ERP PROJECTS
PAVING REPAIR
 SACRAMENTO CITY UNIFIED SCHOOL DISTRICT

DSA FILE NO:
 DSA APPL. NO:
 OPSC APPL. NO:

UNIT:	SHT.	OF	SHTS.
JOB NO.	DATE:		
-	APR 12, 2016		
DRAWN BY	DRAWING NO:		
CHECKED	ADD1-A2		