



**Business Services  
Contracts Office**

5735 47th Avenue • Sacramento, CA 95824  
(916) 643-2464

*Gerardo Castillo, Chief Business Officer  
Kimberly Teague, Contract Specialist*

**ADDENDUM NO. 1**

**Date:** April 15, 2016

**Issued by:** Sacramento City Unified School District

**Project:** Parking Lot Paving at Leataata Floyd ES

You are hereby notified of the following changes, clarifications, or modifications to the original Contract Documents, Specifications, and Drawings. This Addendum shall supersede the original project documents, and shall take precedence over anything to the contrary therein. All Addenda shall be acknowledged in the Bid Form. Failure to do so may result in disqualification of the bid. All other conditions remain unchanged.

- 
1. Clarification: The bid opening time noted in the Pre-Bid meeting minutes was incorrectly indicated as 2:30 p.m. – the bid time is 2:00 p.m.
  2. Bidding Information: If the project is not completed within the stipulated time frame the Owner can impose “Liquidated Damages” in the amount of “\$1,000 per calendar day” that the project is delayed. Number of days to complete this project is 68 days from the date the Notice to Proceed is issued.
  3. The W/K Geotech Report for this site is attached.
  4. Refer to the attached revision details for adjustments being made to the Bid Documents; see attached sheets 1 – 5.

**END OF ADDENDUM NO. 1**

Attachments



March 2, 2016

Lori Rubenstein  
Sacramento City USD  
c/o Premier Management Group  
wsjolund@pmgcm.com

*Pavement Improvement Recommendations*

**LEATAATA FLOYD ES ERP PAVEMENT IMPROVEMENTS**

401 McClatchy Way  
Sacramento, California  
WKA No. 10830.09P

As authorized, we have performed a limited investigation of existing parking lot pavements at the Leataata Floyd Elementary School campus. Our scope of services has included field work to document the existing pavement conditions in areas selected by the project design team, sampling and testing the subgrade soils, engineering analysis, and preparation of this report with pavement construction recommendations.

The existing asphalt concrete (AC) pavement areas we evaluated contained varying amounts of block and longitudinal cracking, alligator cracking, and/or utility trench/pothole repairs. We understand new full-depth pavement repairs are planned for these areas, with minimal changes in the current site finished surface grades. Associated work will include exterior flatwork and utility construction. We also understand AC overlay construction is not considered at this time; therefore our scope of work did not include design or recommendations for AC overlay construction. This letter presents the results of our study and conclusions and recommendations regarding full-depth pavement construction. *Guide Earthwork Specifications* for use in preparing project plans and specifications are included in Appendix A.

Observations and Testing

On February 4, 2016, our representatives cored through the existing pavement at three locations to measure the existing AC and aggregate base (AB) sections. We also drilled to a maximum depth of approximately 4½ feet below the pavement surface at the core locations to observe the subgrade soil conditions. The borings were drilled utilizing a Giddings rotary drill head mounted on a John Deere 6x4 all-terrain utility vehicle. At various intervals, relatively undisturbed soil samples were recovered from the exploratory borings with a 2½-inch O.D., 2-inch I.D., California sampler advanced with a hand-driven slide hammer. Please refer to the attached site plan for approximate core locations. The existing pavement sections at our core locations consisted of the following:

Location	AC Thickness, in.	AB Thickness, in.	Approximate Depth of Boring, ft.
Core No. 1	3½	7½	4½
Core No. 2	1	6	4
Core No. 3	2	4	4

The near-surface soils below the pavement at the core locations generally consisted of dense, gray to brown, silty and clayey fine sands underlain by silty clays and clayey sands to our maximum drilled depth of approximately 4½ feet below the pavement surface. Ground water was encountered approximately 3½ feet below the pavement surface at the location of Core No. 1 in the southwest portion of the parking lot.

Relatively undisturbed tube samples of the near-surface and subsurface soils were obtained at our boring locations and were tested to determine natural moisture content (ASTM D2216) and in-situ dry unit weight (ASTM D2937). Results of our testing indicate the sampled soils have dry unit weights ranging from approximately 93 to 104 pounds per cubic foot (pcf) and moisture contents ranging from approximately 18 to 22 percent. A composite bulk sample of the near-surface soils at Core Nos. 1 and 2 was tested to determine the Resistance value (CTM 301). The test results indicate the composite soil sample possesses a Resistance value of 10. Please refer to the attached soils test results.

Conclusions

*Pavement Subgrade Qualities*

Laboratory testing of anticipated pavement subgrade soils indicates these materials possess a Resistance value of 10, which indicates poor quality materials for support of asphalt concrete pavements.

*On-Site Material Suitability for Engineered Fill Construction*

The on-site soils are considered suitable for use as engineered fill provided that they are clean of significant quantities of organics, rubble and deleterious debris, and are at a suitable moisture content to achieve the recommended compaction.

The existing pavement materials that are removed may be broken up and reused as fill, provided the reuse of this material is approved by the School District. AC pavements should be processed into fragments **less than two inches** in largest dimension and mixed with soil to form a compactable mixture.



If pulverized AC and/or AB is considered for use as Class 2 aggregate subbase in the pavement section, laboratory testing of the final product would be necessary to determine if the material fully complies with all requirements of Class 2 aggregate subbase.

### Recommendations

Site preparation should be accomplished in accordance with the provisions of this report and the appended specifications. A representative of the Geotechnical Engineer should be present during site grading to evaluate compliance with our recommendations. The Geotechnical Engineer of Record referenced herein should be considered the Geotechnical Engineer that is retained to provide geotechnical engineering observation and testing services during construction.

The long-term performance of new AC pavements depends on establishing a firm, stable, soil subgrade. Normal pavement section design methods are based on the assumption that the pavement will support various levels of traffic loading. Presented below are recommendations regarding geotechnical engineering issues in pavement removal and replacement.

#### *Subgrade Preparation Options*

If the current pavement grades are to be preserved to protect existing improvements and site drainage, conventional pavement construction on the in-place, near-surface soil subgrades will require removal of the existing AC and a significant amount of soil.

Alternative construction methods include chemical-treatment of the subgrade soils to increase strength. This method reduces the amount of soil that needs to be removed and reduces the amount of AB required in the pavement section. For estimating and evaluation purposes, a typical chemical-treatment would include approximately 4½ pounds per square foot of high-calcium or dolomitic quicklime or a combination of lime and cement mixed into the upper 12 inches of subgrade soils. **The actual amount of chemical needed and mixing depth should be determined at the time of construction based on the current soil moisture conditions.**

The performance of chemically amended soils is critically dependent on uniform mixing of the chemicals into the subgrade and providing for a proper curing period following amendment with the chemical. An experienced stabilization contractor, coupled with a comprehensive quality control program, is generally required to achieve the best possible stabilized subgrade.

The major disadvantage of chemically amended subgrades supporting pavements results from shrinkage of the treated material, similar to shrinkage of structural concrete, and the potential



for reflective cracking through the asphalt concrete surface. Using a "buffer" layer of aggregate base can mitigate this effect.

If the elevation of the pavement surfaces can be raised, the existing AC can be pulverized to less than two-inch maximum particle size and thoroughly mixed into the subgrade soils (whether chemical-treated or not) as another method to reduce off-haul of materials.

#### *Site Preparation*

Areas to receive new AC pavements should be cleared of existing pavements, below-grade structures, debris, and other deleterious materials to expose firm, undisturbed soils. Where possible, subgrade preparation as detailed below should extend at least three feet beyond the curb lines or edge of pavement. Existing underground utilities should be accurately located and any necessary changes or modifications completed prior to pavement construction. Existing underground utility trench backfill within the proposed pavement areas should be properly backfilled in accordance with the recommendations of this report.

The Geotechnical Engineer or their representative should be present during site clearing operations to verify compliance of the work with our recommendations, and to provide additional recommendations, as needed.

#### *Subgrade Preparation*

Following removal of the existing pavement section, the exposed subgrade soils should be scarified to a depth of six inches, brought to a uniform moisture content of at least two percent above the optimum moisture content, and compacted to at least 95 percent of the ASTM D1557 maximum dry density. Excavations and/or depressions, as well as any loose, soft or saturated soils resulting from the removal of the pavement sections should be cleaned out to firm, undisturbed soils. As noted previously, pulverized AC may be incorporated into the subgrade soils or used as engineered fill.

If the final subgrade will be chemically amended, compaction of the upper 12 inches of the untreated subgrade is not required until the subgrade has been chemically amended.

Soils located beneath existing pavements will likely be at elevated moisture contents regardless of the time of year of construction and will require a significant amount of repeated scarification, blading or discing and/or chemical amendment to reach a moisture content suitable for proper compaction. Wet soils should be anticipated and considered in the construction schedule for the project.



### *Engineered Fill Construction*

Fill placed within the construction area should be an approved material, clean of significant quantities of organics or other deleterious materials. The fill should be spread in level layers not exceeding six inches in compacted thickness and compacted to a minimum of 95 percent of the maximum dry density. Engineered fill should be moisture conditioned at the time of compaction to at least two percent above the optimum moisture content. Maximum dry densities should be determined in accordance with ASTM D1557.

The upper six inches of pavement subgrades, whether achieved by excavation, filling, or left at-grade, should be moisture conditioned to at least two percent above the optimum moisture content and uniformly compacted to not less than 95 percent relative compaction, unless the upper 12 inches of the final pavement subgrade is chemically amended. Pavement subgrades should be proof-rolled with a fully loaded water truck prior to placement of aggregate base to identify areas that may require stabilization and/or re-compaction.

The on-site soils and pulverized asphalt concrete are considered suitable for use as engineered fill provided they are free of rubble larger than two inches in largest dimension, debris and organic concentrations. Imported fill should be an approved compactable, well-graded, granular material, have an Expansion Index of 20 or less, and be clean of particles larger than two inches in maximum dimension. Imported fill that will be chemical-treated should be similar in composition to the on-site soils. The contractor also should supply appropriate documentation for imported fill materials indicating the materials are free of known contamination and have corrosion characteristics within acceptable limits. The Geotechnical Engineer must approve import material before being transported to the project site.

AB should be placed over the completed soil subgrade no longer than 48 hours after final moisture conditioning and compaction. The intent of this recommendation is to minimize degradation and desiccation of the subgrade soils. AB should be compacted to at least 95 percent relative compaction as defined above.

Compaction operations should be performed in the presence of the Geotechnical Engineer or their representative who will evaluate the performance of the subgrade under compactive load and identify loose or unstable soils that could require additional excavation and/or compaction.

### *Utility Trench Backfill*

Utility trench backfill should be mechanically compacted as engineered fill in accordance with the following recommendations. Where possible, the backfill should extend at least three feet beyond the curb lines or edge of pavement. Utility trench backfill should be placed in maximum



six-inch lifts, moisture conditioned to at least two percent above the optimum moisture content, and mechanically compacted to at least 95 percent of the maximum dry density as determined by ASTM D1557.

We recommend that underground utility trenches that are aligned nearly parallel with foundations of existing structures be at least three feet from the outer edge of foundations, wherever possible. As a general rule, trenches should not encroach into the zone extending outward at a 1:1 inclination below the bottom of the foundations. Additionally, trenches parallel to foundations should not remain open longer than 72 hours. The intent of these recommendations is to prevent loss of both lateral and vertical support of foundations, resulting in possible settlement.

#### *Exterior Flatwork Construction*

Exterior slab-on-grade concrete (e.g. sidewalks, flatwork, etc.) should be at least four inches thick and should be supported on at least four inches of Class 2 AB. The soil subgrade beneath the AB layer should be uniformly compacted to at least 95 percent relative compaction and thoroughly moisture conditioned to at least two percent above the optimum moisture content. As described above, AB should be placed and compacted within 48 hours of final subgrade compaction.

Proper moisture conditioning of the subgrade soils is considered essential to the performance of exterior flatwork. Expansion joints should be provided to allow for minor vertical movement of the flatwork and construction joints should be utilized to control where cracking occurs, but will not completely eliminate cracking. Consideration should be given to reinforcing the slabs with rebar for crack control as determined by the project Architect or Civil Engineer. Exterior flatwork should be constructed independent of perimeter building foundations and isolated column foundations by the placement of a layer of felt material between the flatwork and the foundations.

Consideration should be given to thickening the edges of sidewalks to at least twice the slab thickness. Irrigated landscaping adjacent to concrete flatwork will help maintain a more uniform moisture in the soils and reduce the amount of potential differential movement.

#### *Pavement Design Alternatives*

Pavement design analysis has been performed based upon the procedures contained in the *California Highway Design Manual*, 6<sup>th</sup> Edition, using Traffic Indices (TI's) considered appropriate for the anticipated traffic conditions. Our laboratory testing indicates the sampled



near-surface soils possess an R-value of 10, which we used in our pavement design calculations. We can provide additional pavement sections for other TI's as necessary.

PAVEMENT DESIGN ALTERNATIVES

UNTREATED SUBGRADE PAVEMENT DESIGN ALTERNATIVES					
R-value = 10					
Traffic Index (TI)	Traffic Condition	Type B Asphalt Concrete (inches)	Class 2 Aggregate Base (inches)	Class 2 Aggregate Subbase (inches)	Portland Cement Concrete (inches)
4.5	Automobile Parking Only, Hardcourts	2½*	9	---	---
		2½*	6	4	---
6.0	Light Truck Traffic	2½	14	---	---
		2½	11	4	---
		3½*	11	---	---
		3½*	8	4	---
		---	4	---	5
7.0	Fire Truck Traffic	3	17	---	---
		3	14	4	---
		4*	15	---	---
		4*	12	4	---
		---	4	---	6

\* Asphalt concrete thickness contains Caltrans Factor of Safety.

CHEMICALLY-AMENDED SUBGRADE PAVEMENT DESIGN ALTERNATIVES				
R-value = 50				
Traffic Index (TI)	Traffic Condition	Type B Asphalt Concrete (inches)	Class 2 Aggregate Base (inches)	Portland Cement Concrete (inches)
4.5	Automobile Parking Only, Hardcourts	2½	4	---
6.0	Light Truck Traffic	2½	6	---
		3½*	5	---
		---	4	5
7.0	Fire Truck Traffic	3	7	---
		4*	5	---
		---	4	5

\* Asphalt concrete thickness contains Caltrans Factor of Safety.





Pavement design alternates for chemically amended soil are based upon at least 12 inches of the pavement subgrade soils being chemically amended. Based on our experience, we anticipate on-site soils mixed with at least 4½ pounds per cubic foot of amended soil high-calcium or dolomitic quicklime or a combination of lime and cement, and constructed in accordance with the attached *Guide Earthwork Specifications*, will provide a subgrade capable of providing an R-value of 50. However, testing of the field mixture should be performed to verify the design value is achieved.

In the summer heat, high axle loads coupled with shear stresses induced by sharply turning tire movements can lead to failure in asphalt concrete pavements. Therefore, we recommend that consideration be given to using the Portland cement concrete (PCC) section in areas subjected to concentrated heavy wheel loadings, such as driveways and in front of trash enclosures. Joint spacing and details should conform to current Portland Cement Association or American Concrete Institute guidelines. Portland cement concrete should achieve a minimum compressive strength of 3500 psi at 28 days.

Materials, quality and construction of the structural section of the pavement should conform to the applicable provisions of the City of Sacramento Standards and the Caltrans Standard Specifications. We emphasize that the long-term performance of AC pavements is critically dependent on adequate and uniform compaction and stability of the subgrade soils. Grading and drainage should be detailed to avoid ponding of surface water on or adjacent to the pavements.

#### *Site Drainage*

Final site grading should be accomplished to provide positive drainage of surface water away from the pavements, prevent ponding of water adjacent to the pavements, and channel runoff water to appropriate drainage facilities. The finished ground level adjacent to the pavement should be sloped away at a gradient no less than two percent, where possible. Landscape berms, if planned, should not be constructed in such a manner as to promote drainage toward the pavements.

Consideration should be given to constructing full-depth curbs where new pavements abut irrigated landscaping to reduce the potential for moisture migration into the subgrade soils below the pavements, which may lead to reduced support and pavement cracks.

#### Limitations



Our conclusions and recommendations are based on our experience, the results of our limited investigation at the site, and engineering judgment. Our firm should be retained to provide





testing and observation services and engineering consultation if pavement repairs involving earthwork construction are required and/or if it is found during construction that subsurface conditions differ from those we encountered.

Please contact us if you have any questions or require further information.

Wallace - Kuhl & Associates



Joseph D. Waltz, P.E.  
Project Engineer



David T. Hunn, G.E.  
Senior Engineer

Attachments:            Site Plan with Approximate Core Locations (Page 10)  
                                 Laboratory Test Results (Pages 11 & 12)  
                                 APPENDIX A – Guide Earthwork Specifications (Pages A1 – A8)





**Legend**

 Approximate Boring Location

**Site Plan with Approximate Core Locations**  
*Pavement Improvement Recommendations*  
**LEATAATA FLOYD ES ERP PAVEMENT IMPROVEMENTS**  
 WKA No. 10830.09P  
 March 2, 2016  
 Page 10

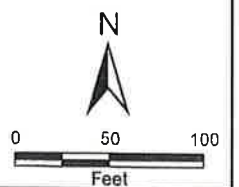

*Pavement Improvement Recommendations*  
**LEATAATA FLOYD ES ERP PAVEMENT IMPROVEMENTS**  
WKA No. 10830.09P  
March 2, 2016  
Page 11

**IN-PLACE SOIL PROPERTIES**

Subgrade Soil Descriptions:	1) Gray, moist, clayey sand (SC) 2) Brown, moist, silty fine SAND (SM) 3) Gray, moist, sandy, silty CLAY (CL)
-----------------------------	---

Location	Depth Below Pavement Surface (in.)	Soil Description	Soil Moisture Content (%)	Soil In-Place Unit Weight (pcf)
Core No. 1	12 – 24	1	21.0	104
	24 – 54	2	-	-
Core No. 2	9 – 36	2	22.1	93
	36 – 48	1	-	-
Core No. 3	9 – 36	2	18.4	93
	36 – 48	3	-	-

NOTES:            Laboratory soil testing was performed on relatively undisturbed 2"x6" tube samples.  
                         Test Methods - Moisture Content ASTM D2216, Unit Weight ASTM D2937.



*Pavement Improvement Recommendations*  
**LEATAATA FLOYD ES ERP PAVEMENT IMPROVEMENTS**  
 WKA No. 10830.09P  
 March 2, 2016  
 Page 12

**RESISTANCE (R) VALUE TEST RESULTS**  
 (CTM 301)

Material Description: Dark brown, sandy clay/clayey sand  
 Location: Bulk sample of near-surface soils from Core Nos. 1 & 2

Specimen Number	Dry Unit Weight	Moisture @ Compaction	Expansion Pressure	Exudation Pressure	R - Value
	(pcf)	(percent)	(dial)	(psf)	(psi)
1	103	20.9	21	91	5
2	104	19.6	54	234	38
3	107	17.9	103	446	50
<b>Equilibrium R-Value at Design Traffic Index of 4.5 = 10</b>					



APPENDIX A  
GUIDE EARTHWORK SPECIFICATIONS  
LEATAATA FLOYD ERP PAVEMENT IMPROVEMENTS  
401 McClatchy Way  
Sacramento, California  
WKA No. 10830.09P

PART I: GENERAL

1.1 SCOPE

A. General Description

This item shall include all clearing of surface vegetation, existing pavements and other deleterious items; preparation of surfaces to be filled, filling, spreading, compaction, observation and testing of the fill; and all subsidiary work necessary to complete the grading of roadway areas to conform with the lines, grades and slopes as shown on the accepted Drawings.

B. Geotechnical Engineer

Where specific reference is made to "Geotechnical Engineer;" this designation shall be understood to include either him or his representative.

1.2 PROTECTION

A. Adequate protection measures shall be provided to protect workmen and passers-by the site. Streets and adjacent property shall be fully protected throughout the operations.

B. In accordance with generally accepted construction practices, the Contractor shall be solely and completely responsible for working conditions at the job site, including safety of all persons and property during performance of the work. This requirement shall apply continuously and shall not be limited to normal working hours.

C. Any construction review of the Contractor's performance conducted by the Geotechnical Engineer is not intended to include review of the adequacy of the Contractor's safety measures, in, on or near the construction site.

D. Adjacent streets and sidewalks shall be kept free of mud, dirt or similar nuisances resulting from earthwork operations.

E. Surface drainage provisions shall be made during the period of construction in a manner to avoid creating a nuisance to adjacent areas.

F. The site and adjacent influenced areas shall be watered as required to suppress dust nuisance.

1.3 GEOTECHNICAL REPORT

A. A Pavement Improvement Recommendations Report (WKA No. 10830.09P; dated March 2, 2016) has been prepared for this site by Wallace - Kuhl & Associates, Geotechnical Engineers of West Sacramento, California [(916) 372-1434]. A copy of that report is available for review at the office of Wallace - Kuhl & Associates.



- B. The information contained in this report was prepared for design purposes only. The Contractor is responsible for any conclusions he/she may draw from this report; should the Contractor prefer not to assume such risk, he/she should employ their own experts to analyze available information and/or to make additional borings upon which to base their conclusions, all at no cost to the Owner.

#### 1.4 EXISTING SITE CONDITIONS

The Contractor shall be acquainted with all site conditions. If unshown active utilities are encountered during the work, the Architect shall be promptly notified for instructions. Failure to notify will make the Contractor liable for damage to these utilities arising from Contractor's operations subsequent to his discovery of such unshown utilities.

#### 1.5 SEASONAL LIMITS

Fill material shall not be placed, spread or rolled during unfavorable weather conditions. When heavy rains interrupt the work, fill operations shall not be resumed until field tests indicate that the moisture contents of the subgrade and fill materials are satisfactory.

### PART II: PRODUCTS

#### 2.1 MATERIALS

##### A. Imported Fill Materials

Imported fill materials shall be approved by the Geotechnical Engineer; they shall be compactable granular soils with an expansion index not exceeding twenty (20) and shall be of two-inch (2") maximum particle size. Import materials also shall be free of known contaminants and have corrosion characteristics within acceptable limits, with appropriate documentation provided by the contractor.

##### B. Local Soils

All fill shall be of approved local materials from required excavations, supplemented by imported fill, if necessary. Approved local materials are defined as local soils free from significant quantities of rubble, rubbish and vegetation, and having been tested and approved by the Geotechnical Engineer prior to use.

##### C. Treated Soils

Materials to be lime-stabilized shall be on-site clayey soils free from significant quantities of rubble, rubbish and vegetation and shall have been tested and approved by the Geotechnical Engineer.

##### D. Lime

1. Lime shall be high-calcium or dolomitic quicklime and must comply with ASTM C977 and the requirements show in the following table:



Lime Quality

Property	ASTM	Requirements
Available calcium and magnesium oxide (min, %)	C25 or C1301 & C1271	High calcium quicklime: CaO > 90 Dolomitic quicklime: CaO > 55 & CaO + MgO > 90
Loss on ignition (max, %)	C25	7 (total loss) 5 (carbon dioxide) 2 (free moisture)
Slaking Rate	C110	30°C rise in 8 minutes

2. A 0.50 lb sample of lime dry-sieved in a mechanical sieve shaker for 10 minutes  $\pm$ 30 seconds must comply with the grading shown in the following table:

Lime Grading

Sieve Sizes	Percentage Passing
3/8-inch	98 - 100

3. In addition to the above, the use of alternative lime products which are of equal quality and of the required characteristics for the purpose intended will be permitted, subject to the following requirements:
  - a. The burden of proof as to quality and suitability of alternatives shall be upon the Contractor and/or Supplier and he shall furnish test data and all information necessary, as required by the Geotechnical Engineer. Written request for alternatives, accompanied by complete data as to the quality and suitability of the material shall be made in ample time to permit testing and approval without delaying the work. The Geotechnical Engineer shall be the sole judge as to the quality and suitability of alternatives and his decision shall be final. Documentation shall be provided to the Geotechnical Engineer no later than two weeks before the alternative material is imported to the site.
  - b. Lime from more than one source or of more than one type may be used on the same project but the different limes shall not be mixed.
  - c. The lime shall be protected from moisture until used and shall be sufficiently dry to flow freely when handled.

E. Cement

Cement should be Type I/II Portland Cement meeting the requirements of ASTM C150.

F. Water

Water for use in subgrade stabilization shall be clean and potable and shall be added during mixing, remixing and compaction operations, and during the curing period to keep the cured material moist until covered.





G. Other Products

Aggregate base, asphalt concrete and related asphalt seal coats, tack coat, etc., shall comply with the appropriate provisions of the most current State of California (Caltrans) Standard Specifications.

PART III: EXECUTION

3.1 LAYOUT AND PREPARATION

Lay out all work, establish grades, locate existing underground utilities, set markers and stakes, set up and maintain barricades and protection of utilities--all prior to beginning actual earthwork operations.

3.2 CLEARING, STRIPPING, AND PREPARING PAVEMENT AREAS

- A. Areas to receive new AC pavements should be cleared of existing pavements, below-grade structures, debris, and other deleterious materials to expose undisturbed native soils. Where possible, subgrade preparation as detailed below should extend at least three feet beyond the curb lines or edge of pavement. Existing underground utility trench backfill within the proposed pavement areas should be properly backfilled in accordance with the recommendations of this report.
- B. Following removal of the existing pavement section, the exposed subgrade soils should be scarified to a depth of six inches, brought to a uniform moisture content of at least two percent above the optimum moisture content, and compacted to at least 95 percent of the ASTM D1557 maximum dry density. Excavations and/or depressions, as well as any loose, soft or saturated soils resulting from the removal of the pavement sections should be cleaned out to firm, undisturbed soils.
- C. All fill to be constructed that will be below the depth of lime-treatment shall be constructed in accordance with Section 3.3 of these specifications and the surfaces receiving fill shall be prepared in accordance with the following paragraphs in this section: Section 3.2.
- D. Where saturated surface soils are located over native undisturbed soils, the subgrades may be stabilized with high-calcium or dolomitic quicklime to depths and with compactive effort meeting the satisfaction of the Geotechnical Engineer.
- E. If drying shrinkage (desiccation) cracking is present in the subgrade soils, prior to the commencement of fill construction or compaction of exposed subgrades, future construction areas shall be repeatedly watered for a period of not less than three days (assuming a dry, summer or fall construction period) and shall continue until the Geotechnical Engineer determines that saturation of the subgrades has been adequate to close the shrinkage cracks. The subgrades shall then be reworked by blading or discing to achieve a uniform moisture content.
- F. The surfaces upon which fill is to be placed shall be plowed or scarified to a depth of at least six inches (6"), until the surface is free from ruts, hummocks or other uneven features which would tend to prevent uniform compaction by the selected equipment.



- G. When the moisture content of the subgrade is less than two percent (2%) over optimum, as defined by the ASTM D1557 Test Method, water shall be added until the proper moisture content is achieved.
- H. When the moisture content of the subgrade is too high to permit the specified compaction to be achieved, the subgrade shall be aerated by blading or other methods until the moisture content is satisfactory for compaction.
- I. After the areas to receive fill have been cleared, moisture conditioned, and plowed or scarified, the subgrade soils shall be recompacted in place to a depth of at least six inches (6") to a minimum of ninety-five percent (95%) of the ASTM D1557 Test Method maximum dry density if these soils will not be lime stabilized.
- J. The pavement areas shall be defined as extending at least three feet (3') beyond the edges of pavement.

### 3.3 CONSTRUCTION OF UNTREATED SUBGRADES

- A. The selected soil fill material shall be placed in layers which, when compacted, do not exceed six inches (6") in thickness. Each layer shall be spread evenly and shall be thoroughly mixed during the spreading to promote uniformity of material in each layer.
- B. When the moisture content of fill material is less than two percent (2%) over optimum moisture, as defined by the ASTM D1557 Test Method, water shall be added until the proper moisture content is achieved.
- C. When the moisture content of the fill material is too high to permit the specified degree of compaction to be achieved, the fill material shall be aerated by blading or other methods until the moisture content is satisfactory.
- D. After each layer of fill has been placed, mixed and spread evenly, it shall be thoroughly compacted to not less than ninety-five percent (95%) of maximum dry density as determined by the ASTM D1557 Test Method. Compaction shall be undertaken with equipment capable of achieving the specified density and shall be accomplished while the fill material is at the required moisture content. Each layer shall be compacted over its entire area until the desired density has been obtained.
- E. The upper six inches (6") of any untreated, pavement subgrades shall be uniformly compacted to at least ninety-five (95%) percent of the ASTM D1557 Test Method maximum dry density, at not less than two percent above the optimum moisture content.
- F. The fill operations shall be continued until the fills have been brought to the slopes and grades shown on the accepted Drawings.

### 3.4 LIME-STABILIZED SUBGRADE CONSTRUCTION

- A. Placing Material  
The material to be treated shall be placed at a moisture content at least two percent (2%) over optimum moisture as defined by the ASTM D1557 Test Method.
- B. Preparing Material  
Material to be treated shall be scarified and thoroughly broken up to the full depth and width to be stabilized. The material to be treated shall contain no rocks or solids larger than one and one-half inches (1½") in maximum dimension.



C. Mixing

1. Lime shall be added to the material to be treated at a rate of not less than four and one half pounds (4½ lb.) of lime per cubic foot of soil treated.
2. Lime shall be spread by equipment that will uniformly distribute the required amount of lime for the full width of the prepared material. The rate of spread per linear foot of blanket shall not vary more than five percent (5%) from the designated rate.
3. The spread lime shall be prevented from blowing by suitable means selected by the Contractor. Quicklime shall not be used to make lime slurry. The spreading operations shall be conducted in such a manner that a hazard is not present to construction personnel or the public. All lime spread shall be thoroughly ripped in, or mixed into, the soil the same day lime spreading operations are performed.
4. No traffic other than the mixing equipment will be allowed to pass over the spread lime until after the completion of mixing.
5. Mixing equipment shall be equipped with a visual depth indicator showing mixing depth, an odometer or footmeter to indicate travel speed and a controllable water additive system for regulating water added to the mixture.
6. Mixing equipment shall be of the type that can mix the full depth of the treatment specified and leave a relatively smooth bottom of the treated section. Mixing and re-mixing, regardless of equipment used, will continue until the material is uniformly mixed (free of streaks or pockets of lime), moisture is at approximately two percent (2%) over optimum and the mixture complies with the following requirements:

Minimum

<u>Sieve Size</u>	<u>Percent Passing</u>
1-1/2"	100
1"	95
No. 4	60

7. Non-uniformity of color reaction when the treated material, exclusive of one inch or larger clods, as tested with the standard phenolphthalein alcohol indicator, will be considered evidence of inadequate mixing.
8. Lime-treated material shall not be mixed or spread while the atmospheric temperature is below 35°F.
9. Remixing of the treated soil shall be performed no sooner than 12 hours after the initial mixing, and no later than 72 hours after the initial mixing. The entire mixing operation shall be completed within seventy-two (72) hours of the initial spreading of lime, unless otherwise approved by the Geotechnical Engineer.

D. Spreading and Compacting

1. The treated mixture shall be spread to the required width, grade and cross-section. The maximum compacted thickness of a single layer may be determined by the Contractor provided he can demonstrate to the Geotechnical Engineer that his equipment and method of operation will provide uniform distribution of the lime and the required compacted density



throughout the layer. If the Contractor is unable to achieve uniformity and density throughout the thickness selected, he shall rework the affected area using thinner lifts until a satisfactory treated subgrade meeting the distribution and density requirements is attained, as determined by the Geotechnical Engineer, at no additional cost to the Owner.

2. The finished thickness of the lime-treated material shall not vary more than one-tenth foot (0.1') from the planned thickness at any point.
3. The lime-treated soils shall be compacted to a relative compaction of not less than ninety-five percent (95%) as determined by the ASTM D1557 Test Method.
4. Initial compaction shall be performed by means of a sheepsfoot or segmented wheel roller. Final rolling shall be by means of steel-drum or pneumatic-tired rollers.
5. Areas inaccessible to rollers shall be compacted to meet the minimum compaction requirement by other means satisfactory to the Geotechnical Engineer.
6. Final compaction shall be completed within seventy-two (72) hours of initial mixing, and within four (4) hours of the final mixing. The surface of the finished lime-treated material shall be the grading plane and at any point shall not vary more than eight one hundredths of a foot (0.08') foot above or below the grade established by the Civil Engineer except that when the lime-treated material is to be covered by material which is paid for by the cubic yard the surface of the finished lime-treated material shall not extend above the grade established by the Civil Engineer.
7. Before final compaction, if the treated material is above the grade tolerance specified in this section, uncompacted excess material may be removed and used in areas inaccessible to mixing equipment. After final compaction and trimming, excess material shall be removed and disposed of. The trimmed and completed surface shall be rolled with steel or pneumatic-tired rollers. Minor indentations may remain in the surface of the finished material so long as no loose material remains in the indentations.
8. At the end of each day's work, a construction joint shall be made in thoroughly compacted material and with a vertical face. After a part-width section has been completed, the longitudinal joint against which additional material is to be placed shall be trimmed approximately three inches (3") into treated material, to the neat line of the section, with a vertical edge. The material so trimmed shall be incorporated into the adjacent material to be treated.
9. An acceptable alternate to the above construction joints, if the treatment is performed with cross shaft rotary mixers, is to actually mix three inches (3") into the previous day's work to assure a good bond to the adjacent work.

E. Curing

The surface of each compacted layer of lime-treated material shall be kept moist until covered by a subsequent layer of lime-treated soil or other gravel or aggregate base material. The final layer of lime-treated material shall be kept moist for at



least three (3) days after final trimming and rolling. No equipment or traffic shall be permitted on the lime-treated material during the first three (3) days of moist curing or after applying the curing seal.

### 3.5 LIME AND CEMENT STABILIZED SUBGRADE CONSTRUCTION

Subgrade stabilization with lime and cement shall be accomplished in accordance with Section 3.4, except only the lime shall be mixed into the subgrade soils the first day. The cement shall be spread just prior to the remix and mixed into the subgrade during the remix of the lime-treated soil. Final compaction shall be completed within ten (10) hours of final mixing.

### 3.6 CEMENT STABILIZED SUBGRADE CONSTRUCTION

Subgrade stabilization with cement shall be accomplished in accordance with Section 3.4, except the remix is not required. Final compaction shall be completed within ten (10) hours of final mixing.

### 3.7 TESTING AND OBSERVATION

- A. All grading operations, including lime-treatment of the subgrades, shall be tested and observed by the Geotechnical Engineer, serving as the representative of the Owner.
- B. Field density tests shall be made by the Geotechnical Engineer after compaction of each layer of fill. Additional layers of fill shall not be spread until the field density tests indicate that the minimum specified density has been obtained.
- C. Earthwork shall not be performed without the notification or approval of the Geotechnical Engineer. The Contractor shall notify the Geotechnical Engineer at least two (2) working days prior to commencement of any aspect of the site earthwork.
- D. If the Contractor should fail to meet the technical or design requirements embodied in this document and on the applicable plans, he shall make the necessary readjustments until all work is deemed satisfactory, as determined by the Geotechnical Engineer and the Architect/Engineer. No deviations from the specifications shall be made except upon written approval of the Geotechnical Engineer or Architect/Engineer.

/



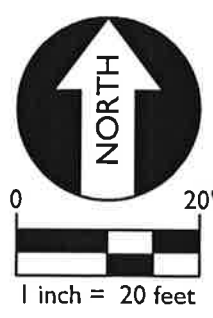
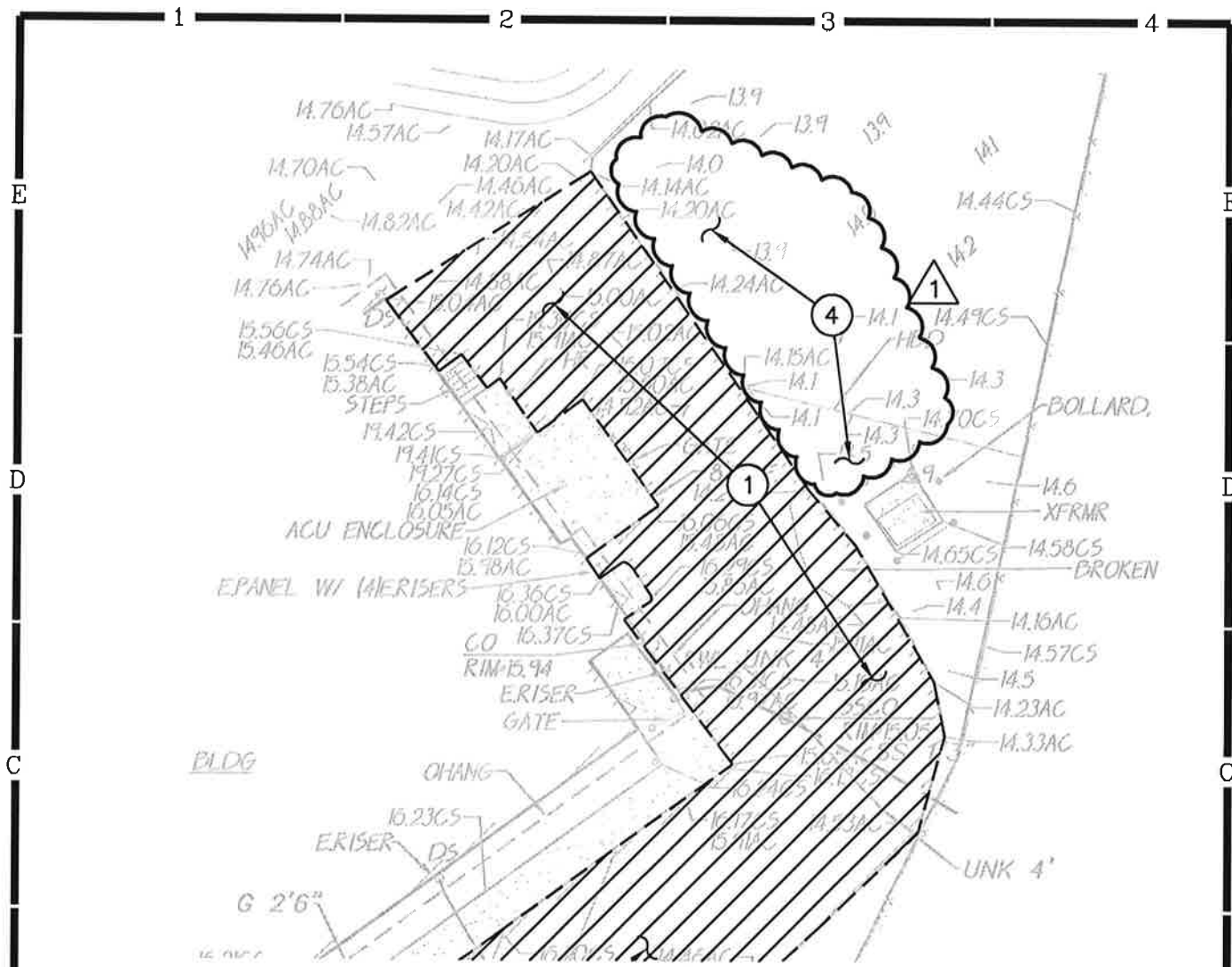

**DEMOLITION NOTES**

4. PATCH EXISTING TURF AND MODIFY EXISTING IRRIGATION AS NECESSARY FOR NEW WORK.

**WCE**  
**WARREN CONSULTING ENGINEERS, INC.**  
 1117 WINDFIELD WAY, SUITE 110  
 EL DORADO HILLS, CA 95762 (916) 985-1870

(REFERENCE SHEET C1.1)

**HMC Architects**  
 2495 Nalomas Park Drive, Studio 655 / Sacramento, CA 95833  
 T 916.325.1100 / www.hmcarchitects.com

Project Title				
LEATAATA FLOYD ELEMENTARY SCHOOL				
Drawing Title				
DEMOLITION PLAN				
Designed	Drawn	Reviewed	Date	Scale
TF	ML	TF	04-14-16	AS NOTED

ADDENDUM 1 - SHEET 1

15-248 C1.1A

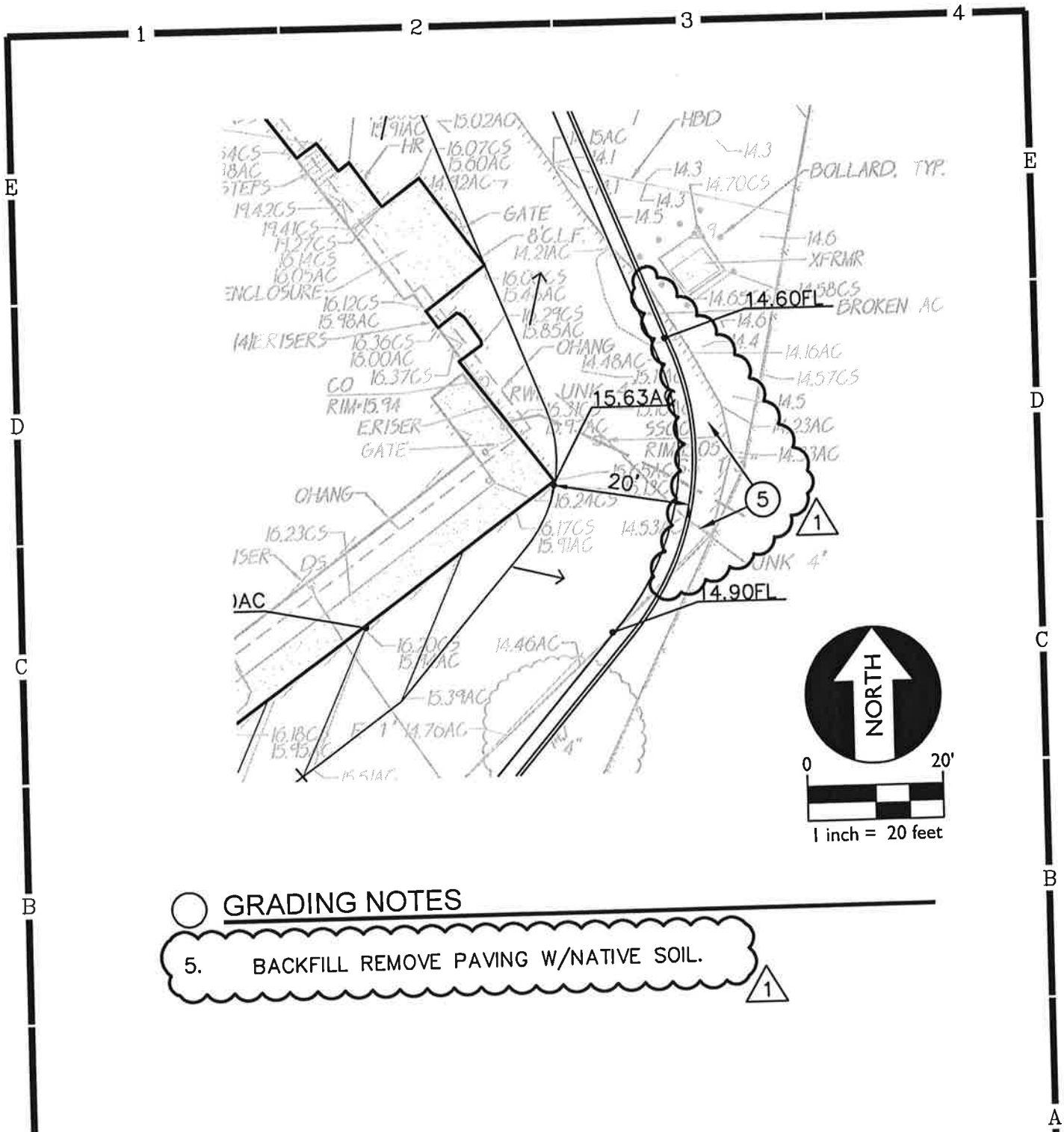

**GRADING NOTES**

5. BACKFILL REMOVE PAVING W/NATIVE SOIL.

**WCE**  
**WARREN CONSULTING ENGINEERS, INC.**  
 1117 WINDFIELD WAY, SUITE 110  
 EL DORADO HILLS, CA 95762 (916) 985-1870

(REFERENCE SHEET C2.1)

**HMC Architects**  
 2495 Natomas Park Drive, Studio 555 / Sacramento, CA 95833  
 T 916.325.1100 / www.hmcarchitects.com

Project Title  
**LEATAATA FLOYD ELEMENTARY SCHOOL**

Drawing Title  
**GRADING PLAN**

Designed	Drawn	Reviewed	Date	Scale
TF	ML	TF	04-14-16	AS NOTED

ADDENDUM 1 - SHEET 2

15-248 C2.1A

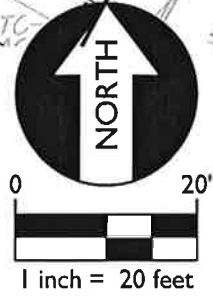
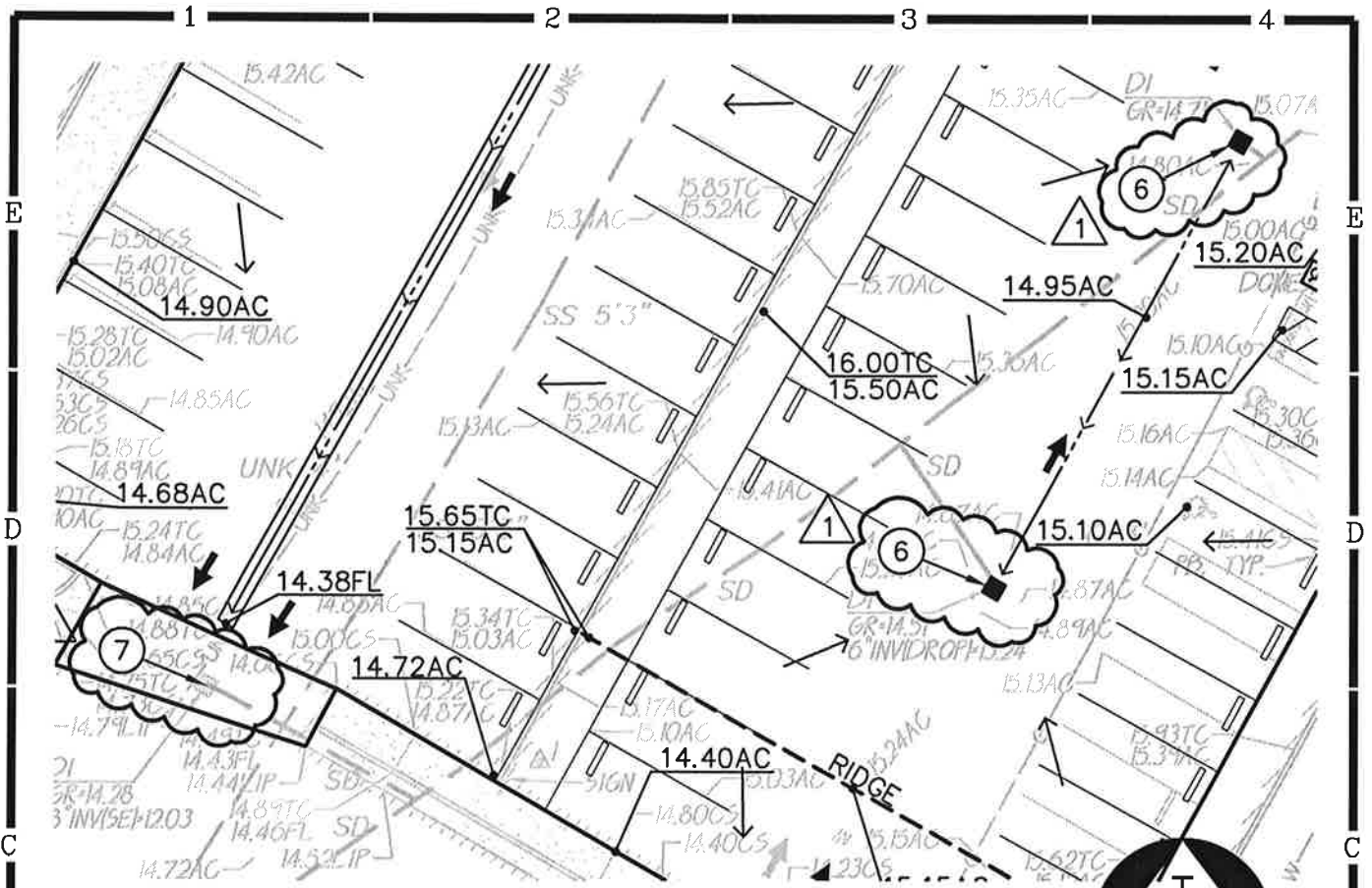

**GRADING NOTES**

- 6. REMOVE FRAME AND GRATE. REPLACE W/FRAME AND GRATE PER 1  
C2.1  
PROVIDE CONCRETE/MORTAR TO TRANSITION TO EXISTING INLET.
- 7. EXISTING INLET TO REMAIN.



**WARREN CONSULTING ENGINEERS, INC.**  
 1117 WINDFIELD WAY, SUITE 110  
 EL DORADO HILLS, CA 95762 (916) 985-1870

(REFERENCE SHEET C2.1)



2495 Natomas Park Drive, Studio 655 / Sacramento, CA 95833  
 T 916.325.1100 / www.hmcarchitects.com

Project Title  
**LEATAATA FLOYD ELEMENTARY SCHOOL**

Drawing Title  
**GRADING PLAN**

Designed	Drawn	Reviewed	Date	Scale
TF	ML	TF	04-14-16	AS NOTED

ADDENDUM 1 - SHEET 3

15-248 C2.1B



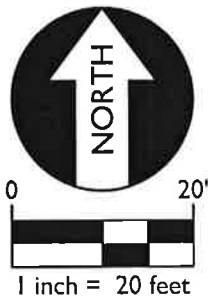
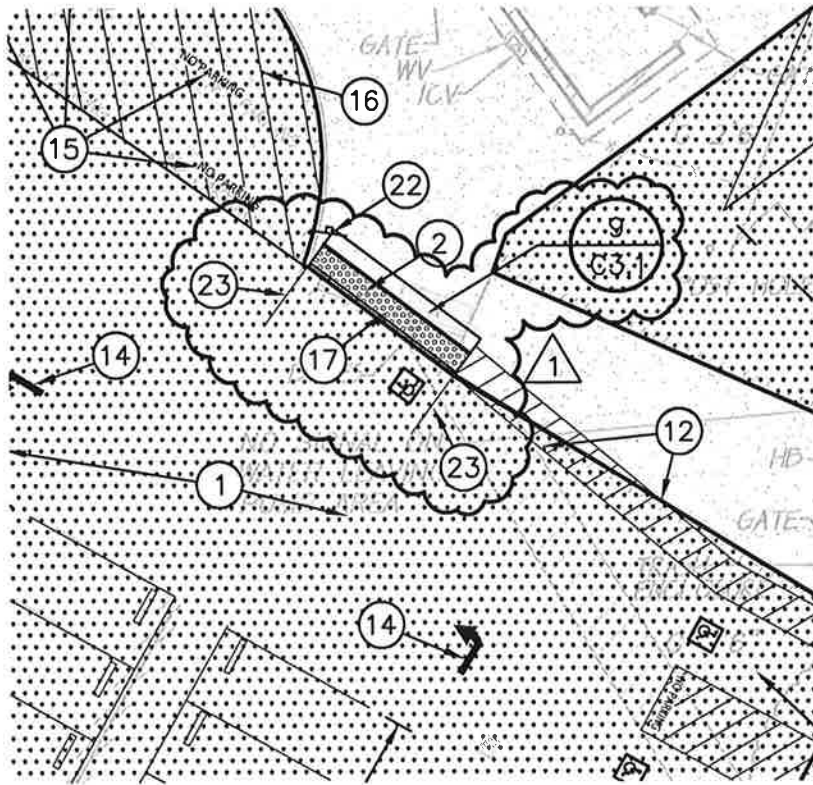

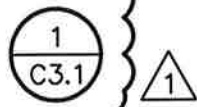
- # PAVING NOTES**
- 23. PAINT 4" WIDE 8' LONG BLUE OUTLINE STRIPE.
  - 24. PAINT 36"X36" SYMBOL OF ACCESSIBILITY PER 

**WCE**  
**WARREN CONSULTING ENGINEERS, INC.**  
 1117 WINDFIELD WAY, SUITE 110  
 EL DORADO HILLS, CA 95762 (916) 985-1870

(REFERENCE SHEET C3.1)

**HMC Architects**  
 2495 Natomas Park Drive, Studio 655 / Sacramento, CA 95833  
 T 916.325.1100 / www.hmcarchitects.com

Project Title  
**LEATAATA FLOYD ELEMENTARY SCHOOL**

Drawing Title  
**PAVING PLAN**

Designed	Drawn	Reviewed	Date	Scale
TF	ML	TF	04-14-16	AS NOTED

ADDENDUM 1 - SHEET 4

15-248 C3.1A

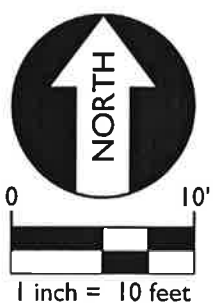
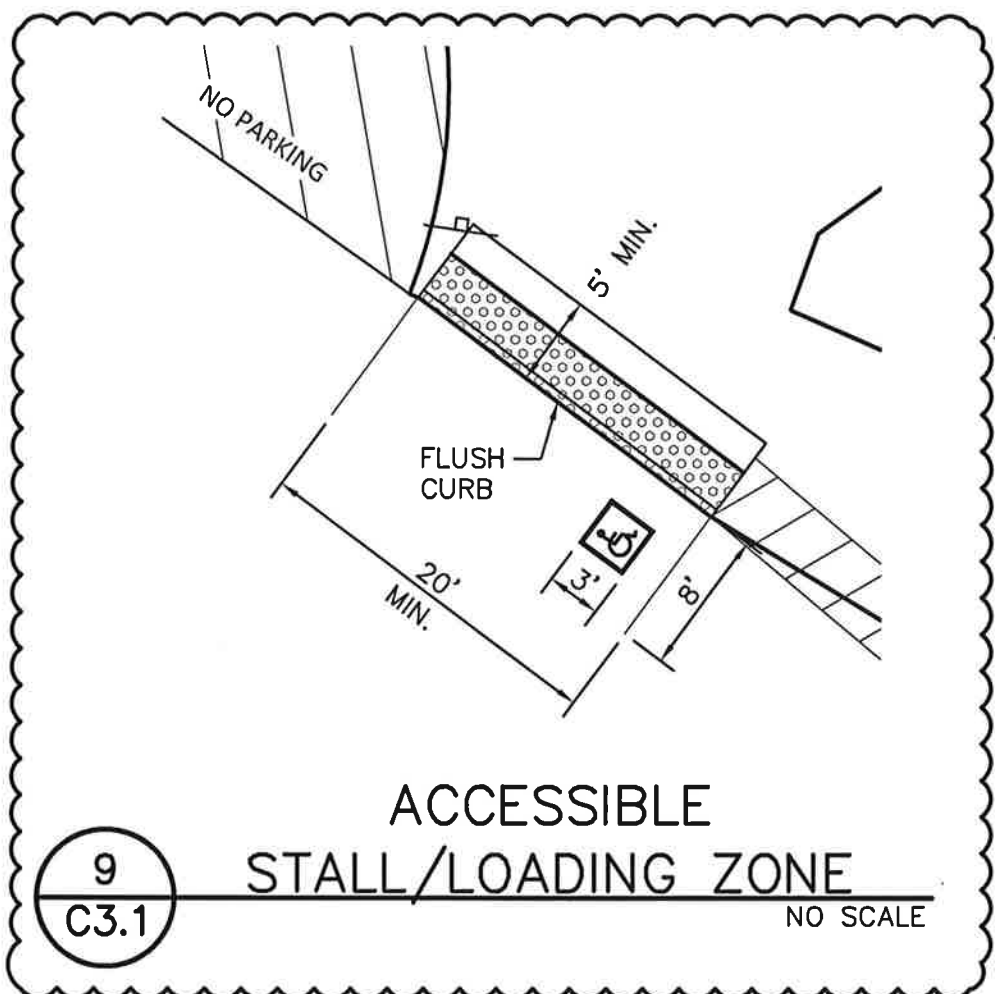

**WCE**  
**WARREN CONSULTING ENGINEERS, INC.**  
 1117 WINDFIELD WAY, SUITE 110  
 EL DORADO HILLS, CA 95762 (916) 985-1870

(REFERENCE SHEET C3.1)

**HMC** Architects  
 2495 Natomas Park Drive, Studio 655 / Sacramento, CA 95833  
 T 916.325.1100 / www.hmcarchitects.com

Project Title  
**LEATAATA FLOYD ELEMENTARY SCHOOL**

Drawing Title  
**PAVING PLAN**

ADDENDUM 1 - SHEET 5

Designed	Drawn	Reviewed	Date	Scale
TF	ML	TF	04-14-16	AS NOTED

15-248 C3.1B